

Oil Rotary Vacuum Pump

INSTRUCTION MANUAL

Model
VS-Series
VS300A-W



Before Use of This Pump

We would really appreciate your purchasing VS300A-W (hereinafter referred to as "this pump"), an oil rotary vacuum pump of ULVAC KIKO, Inc. (hereinafter referred to as "we" or "us").

Upon receipt of the machine, please confirm the contents included are the same as you ordered and check the machine for any damage attributed to transportation etc. just in case.

This instruction manual (hereinafter, "this manual") describes appropriate handling and maintenance procedures to safely use this pump and to maximize its performance. Read this manual in advance to properly use this pump.

Install and operate this pump according to the local and national safety laws and regulations (such as fire laws and electric wiring code). It is required to take a training for general safety of the country and the local area where this pump will be used. Do not use this pump without any training.

The operator is required to have taken such trainings. In addition, the operator must have expertise, skills, qualifications in electrics, mechanics, cargo handling, vacuum, etc.

This pump has been designed to conform to the rules in place when this manual was created. Conformity is not guaranteed because the applicable standards may change in the future.

Performance and safety may not be ensured if equipment connected to this pump does not conform to the same rules or if the pump is altered. In such cases, we cannot guarantee (take responsibility for) performance or safety. Product alterations made by the customer are not covered by the warranty, and we cannot take responsibility for them.

Before installing or removing this pump, separate all energy sources (including power, compressed air, and cooling water) from the product.

None of this pump's parts may continue to be used permanently while maintaining the performance upon delivery. Performance inevitably degrades after a certain amount of time elapses, thus increasing the likelihood of product problems even in assumed common usage scenarios. We ask that our customers perform preventive maintenance to avoid problems in accordance with their usage scenarios. By performing preventive maintenance measures, you can lower the probability of problems with this pump due to parts failures caused by parts becoming worn out as well as the probability of other risks, such as downtime caused by pump problems, fire, or effects on other processes. From the viewpoint of preventive maintenance, we also ask our customers to prepare maintenance and inspection plans and to replace parts and perform overhauls according to such plans.





If you have any questions about handling or other matters, please contact our nearest sales office or dealer.

Safety Indications









Signal words and symbol marks are used in the warning indications contained in this manual and on the product so that the user can understand the matters to be observed. Their meanings are as follows.

► Definition of signal words:

The terms that signify the warning level for safety are referred to as "Signal Words."

	Indicates an imminent possibility that incorrect handling may lead to the user's death or serious injury.
	Indicates a possibility that incorrect handling may lead to the user's death or serious injury.
	Indicates a possibility that incorrect handling may lead to the user suffering a medium-level injury.
	Indicates important information not related to human injury.





► Definition of pictograms:

	Indicates potential risks related to human injury.
	Indicates potential risks related to electrical shock.
	Indicates potential risks related to high temperature.
	Indicates the matters "Prohibited" or must not to do.
	Indicates the matters "Compulsory" or must to do.
	Indicates that a protective gloves must be worn.
	Indicates that a protective glasses must be worn.
	Indicates that the instruction manual must be referred.

Warning Label Types and Display Positions

A warning label is attached onto a warning location on the machine. Before operating this pump, be sure to confirm the warning contents.

► Warning Label Types and Descriptions

	<p>Parts with this warning label have a risk of electrical shock. Turn off the primary power supply before starting wiring or maintenance.</p>
	<p>During operation or for a while after operation stops, do not touch the unit as each portion is at a very high temperature. Touching it may cause burns.</p>
	<p>Do not operate this pump while equipment is attached that prevents gas from moving to the exhaust port (e.g., that blocks the exhaust port). The pump's internal pressure may rise, causing the casing or level gauge to rupture, oil leakage, or motor overload. Explosive or flammable gas, gas that increases the susceptibility of substances to fire, or other gas may ignite inside the pump, thus increasing the pump's internal pressure. Do not exhaust gas that has these characteristics.</p> <p>Before pumping such a gas, dilute it sufficiently to the extent that the risk of explosion and ignition is eliminated.</p>
	<p>Before use, read through the instruction manual and fully understand its contents.</p>

► Warning Label display position

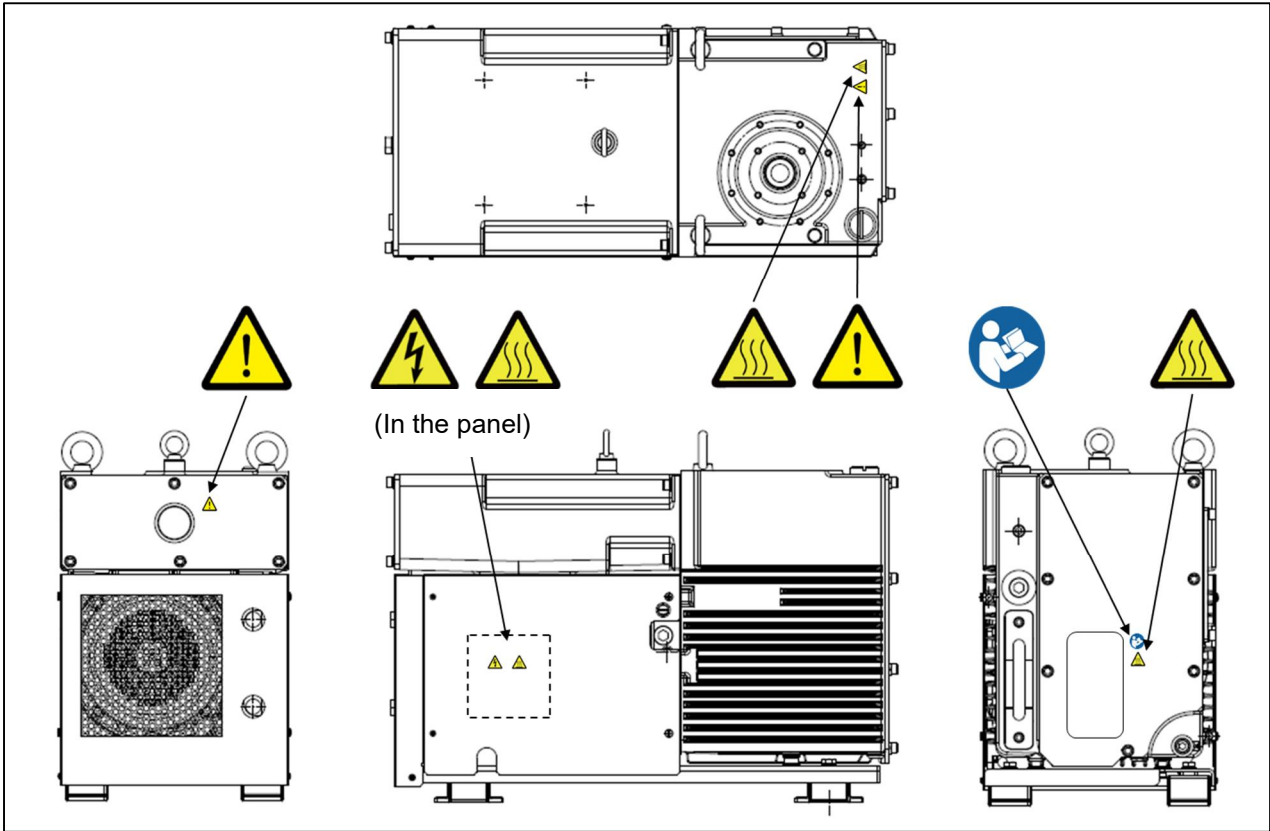

Figure: Warning label pasting position (VS300A-W)

Warranty Terms

Although this pump undergoes our stringent internal inspection before shipment, if there are any failures attributable to us such as a manufacturing defect or accident during shipping, contact our nearest sales office or dealer. We will repair or replace it free of charge.

▶ Warranty Product

- (a) Oil Rotary Vacuum Pump VS300A-W

▶ Warranty Period

- (a) Transactions in Japan: One year from the shipment date
- (b) Direct export transactions: One year from the B/L date

▶ Warranty Scope

(a) Transactions in Japan:

- For a product at the time of delivery with a damage because of trouble during transportation.
- For a product not satisfying the basic specification in spite of using the product within the service condition (temperature range, power supply, etc.).

(b) Direct export transactions:

- For a product at the time of delivery with a damage because of trouble during transportation. However, for direct export transactions, it shall conform to the warranty coverage of International Commercial Terms (INCOTERMS etc.) defined at the time of each transaction.
- For a product not satisfying the basic specification in spite of using the product within the service condition (temperature range, power supply, etc.).

▶ Disclaimer

The warranty does not cover the product failures listed below or those due to one of the following causes; we will charge for such repairs even during the warranty period.

- Failures or defects due to influence of corrosion or generated gas or product that are attributed to the process environment.
- Failures or defects caused by consumables.
- When the power voltage or frequency of the power supply used differs from what was specified at the time of order.
- Failures or defects caused by natural disasters such as fires, floods, earthquakes, or lightning, or force majeure such as war.
- Failures or defects caused by handling errors or incorrect usage.
- Products modified/disassembled/repared without our permission.
- Failures or defects caused by use in an abnormal environment including strong electromagnetic fields, radioactive environments, high temperatures, high humidity, flammable gas atmospheres, corrosive gas atmospheres, and dust.
- Failures or defects due to noise.
- Secondary damage incurred by the customer caused by product defects or claims from third

- parties on violation of patents.
- When our engineers judge that the failures or defects are caused under the conditions of use inappropriate to this product or not satisfied.
 - Products for which the warranty period has elapsed.

▶ **Response**

(a) Transactions in Japan:

We will send a substitute product, or repair the product returned to us or our nearest ULVAC TECHNO office.

If on-site action is required, contact our nearest sales office or dealer separately.

(b) Direct export transactions:

We will send a substitute product, or repair the product returned to us or our nearest service center.

▶ **Others (Warranty terms)**

- (a)** If there are individual contracts and memorandum related to specifications in addition to this manual, the contents in those documents prevail.
- (b)** Before exporting this pump from Japan, contact us and perform the necessary procedures according to the provisions of export-related laws such as the Foreign Exchange and Foreign Trade Law.
- (c)** For any questions and consultation on this pump, confirm the model and manufacturing number and then contact our nearest sales office or dealer.
https://www.ulvac.co.jp/en/support_info/
- (d)** Note that the contents in this manual is subject to change without notice.

About this Manual

- To ensure this pump remains usable for a long time, before installing, operating, inspecting, or maintaining it, be sure to read this manual and fully understand the safety notes as well as the pump's specifications and operating procedures.
- Note that the specifications, prices, and other contents in this manual are subject to change without notice for improvement or other reasons. Changes are released as a revision that updates the manual number listed on the top-right corner of the instruction manual's cover.
- Be sure to give this manual to the end user who uses the product.
- Copying this instruction manual in whole or in part for third parties without our permission is strictly prohibited.
- This manual is intended for users whose native language is English. If users whose native language is not English perform work related to this pump, thoroughly provide safety training and handling instructions under your own responsibility.
- This instructions manual is copyrighted by ULVAC KIKO Inc.

NOTES



To use this product in Quebec, Canada, labels and an instruction manual in French are required. Consult us in advance.

Table of Contents

Before Use of This Pump.....	i
Safety Indications	ii
▶ Definition of signal words:.....	ii
▶ Definition of pictograms:	ii
Warning Label Types and Display Positions.....	iii
▶ Warning Label Types and Descriptions	iii
▶ Warning Label display position	iv
Warranty Terms	v
▶ Warranty Product	v
▶ Warranty Period	v
▶ Warranty Scope.....	v
▶ Disclaimer.....	v
▶ Response	vi
▶ Others (Warranty terms)	vi
About this Manual.....	vii
1. For Safety Use.....	1
1.1 Handling of this pump	1
1.2 Acceptance/Transfer/Storage.....	2
1.2.1 Acceptance	2
1.2.2 Transfer	3
1.2.3 Storage.....	3
1.3 Installation/Operation	3
1.4 Removal.....	4
1.5 Protective Device	4
1.6 This pump intrinsic hazards and safety measures	5
1.6.1 Vacuum pumping and exhaust of hazardous gases or substances	5
1.6.2 Transfer of heavy object.....	5
1.6.3 Electrical shock	6
1.6.4 High temperature	6
1.6.5 Ruptures.....	7
1.6.6 Leakage of high-temperature cooling water	7
1.7 Safety Data Sheet	7
2. Product Overview	9
2.1 Application Purpose	10
2.2 Principles of Pumping	10
2.3 Performance Curve.....	11
2.3.1 Ultimate pressure	11
2.3.2 Pumping speed	11
2.3.3 Power consumption.....	11
2.4 Name and Function of Parts	13
2.5 System Configuration.....	14

3. Installation.....	15
3.1 Before Installation	15
3.1.1 Responsibility for work from shipping to startup	15
3.1.2 Storage environment requirements	16
3.1.3 Environmental requirements for installation and operation	16
3.2 Unpacking	17
3.2.1 Precautions for unpacking	17
3.2.2 Confirmation after unpacking	17
3.3 Transfer.....	18
3.3.1 How to hoist using crane.....	19
3.3.2 How to transport using pallet truck	20
3.4 Installation.....	21
3.4.1 Leveling (For Optional Caster Models).....	22
3.4.2 Earthquake countermeasures.....	22
3.5 Oil Filling	24
3.6 Piping and Wiring	26
3.6.1 Inlet/Exhaust port piping	28
3.6.2 Oil mist separator	29
3.6.3 Cooling water piping	30
3.6.4 Gas ballast gas	32
3.6.5 Pump's ultimate pressure and operating noise	33
3.6.6 Purge gas.....	34
3.7 Electric Wiring	35
3.7.1 Electric wiring	35
3.7.2 Wire connection of 24 VDC power connections	39
4. Operation.....	41
4.1 Precautions on operation	41
4.2 Preparation for Operation.....	45
4.2.1 Pre-operation check.....	45
4.3 How to Startup/Stop	46
4.3.1 Startup.....	46
4.3.2 Stop	46
4.3.3 Drain of this pump	47
4.3.4 Gas ballast function.....	47
5. Removal.....	49
5.1 Removal of Piping	50
5.1.1 Cooling water piping	50
5.1.2 Inlet/exhaust port piping.....	51













6. Maintenance and Inspection	53
6.1 Daily Inspection.....	53
6.2 Regular Inspection	54
6.2.1 Inspection and replacement of oil	54
6.2.2 Oil leakage check.....	56
6.2.3 Inspection of abnormal noise and vibration	56
6.2.4 Inspection and replacement of oil mist separator	57
6.2.5 Replacement of exhaust valve plate.....	59
6.2.6 Cleaning of oil tank.....	61
6.2.7 Inspection of automatic drain valve	62
6.2.8 Replacement of oil filter	64
6.2.9 Maintenance and cleaning of heat exchanger.....	65
6.2.10 Inspection of oil drain port (Drain valve).....	65
6.3 Inspection after Long-Term Storage	66
6.4 Overhaul	66
6.5 Notes on Pump Transportation	66
7. Troubleshooting.....	67
7.1 Trouble with Basic Operation	67
8. Specifications	71
8.1 Performance Specifications.....	71
8.2 External Dimensions	73
Appendix	75
Major replacement parts.....	75

1. For Safety Use

This chapter describes how to reduce risks as well as which dangerous behaviors must be avoided for each work item.

▶ 1.1 Handling of this pump

If you need an overhaul or repair or if you have a problem, contact our nearest service center.

 DANGER 	<p>This manual assumes that this pump's interlock system or control system has been integrated into the host equipment. Connect the pump's power line to the host equipment's EMO system.</p>
 DANGER 	<p>This pump can exhaust inert gas (air, nitrogen, or argon). If the pump exhausts other gas (toxic, combustible, corrosive, or explosive gas, or gas that increases the susceptibility of substances), such gas may leak from the pump's main unit or ignite or explode inside the pump. Therefore, do not use this pump to exhaust such gases. If to use this pump, dilute such a gases sufficiently to the extent that the risk of explosion and ignition is eliminated before pumping.</p>
 DANGER 	<p>Install this pump in a ventilated room indoors. If nitrogen or argon leaks, the lack of oxygen may cause suffocation.</p>
 DANGER 	<p>Before installing or removing this pump, separate all energy sources (including power and cooling water) from it.</p>
 DANGER 	<p>When toxic gases were pumped, not only this pump but also the oil becomes toxic. Please be careful during maintenance.</p>
 DANGER 	<p>Before installing or removing this pump, separate all energy sources (including power, compressed air, and cooling water) from it. * If you are using compressed air, nitrogen gas, or other gases, remove it.</p>
<p>NOTES</p> 	<p>Install appropriate traps, such as filters, separators and/or condensers to prevent the ingress of liquid and solid particles to this pump.</p>

- This pump has been designed to conform to the rules in place when this manual was created. Conformity is not guaranteed because the applicable standards may change in the future.
- Performance and safety may not be ensured if equipment connected to this pump does not conform to the same rules or if the pump is altered. In such cases, we cannot guarantee (take responsibility for) performance or safety.











- Do not handle this pump if you have not undergone publicly recognized general safety training (including on electrical and loading safety) in your country. The operator must attend such training.
- Install and operate this pump according to the safety-related laws and regulations (such as fire prevention laws and electrical wiring regulations) in your country.
- If the details of dangerous substances to be used is not disclosed, or the substances difficult to undergo a detoxification processing are discharged, we may reject the maintenance and other related handlings.
If you entrust us of an overhaul, maintenance, or repair etc., enter the necessary information in the "Declaration of Contamination" attached to the end of this manual and submit it to a service center.
- Before exporting this pump from Japan, it must undergo screening according to the Foreign Exchange and Foreign Trade Law as well as government ordinances, ministerial ordinances, notices, and other orders based on said law. Contact our nearest sales office or dealer.

【List of sales offices】

https://www.ulvac.co.jp/en/support_info/sales_office/





▶ 1.2 Acceptance/Transfer/Storage

1.2.1 Acceptance

 DANGER 	<p><u>Never get under this pump</u></p> <p>This pump may fall or topple if a forcible operation is performed or if the equipment is not sufficiently maintained. Never get under this pump.</p>
 WARNING 	<p><u>Ask a specialist company to perform disassembly.</u></p> <p>This pump comes packaged in a wooden crate, cardboard box, or other material. Ask a specialist company to perform disassembly. Workers may cut their hands on nails or wooden chips during work. Instruct those who disassemble the machine to wear leather gloves and to use an appropriate bar or other disassembly tool.</p>
 WARNING 	<p><u>Use a crane or other cargo-handling equipment</u></p> <p>Give instructions to hoist and transfer this pump using a crane or other cargo-handling equipment and eyebolts on the top of this pump when unpacking or hoisting it. Before using the eyebolts, confirm that there are no abnormalities.</p>
 WARNING 	<p><u>Certified persons must perform loading work and operate the cargo-handling machine.</u></p> <p>Never perform loading work or operate the cargo-handling machine if you do not have the appropriate certifications.</p>
 WARNING 	<p><u>Do not incline this pump by 10 or more.</u></p> <p>Otherwise, this pump may topple, causing injury or damage.</p>

NOTES	<u>After unpacking, make sure that there are no missing items or damage</u>
	<p>After unpacking, make sure that there are no missing, damaged, or abnormal items. If there are any problems, do not perform installation work.</p> <p>* For accessories, refer to "Table 2: List of standard accessories" on page 18.</p>







1.2.2 Transfer



 WARNING	<p><u>Do not use the casters as a transportation device or a means of equipment support.</u></p> <p>Although this pump is equipped with casters, do not use them as a transportation device or a means of equipment support.</p>
	
 WARNING	<p><u>For transport, use cargo-handling equipment or a pallet truck.</u></p> <p>To transport this pump, a load higher than the safety standards is required. Therefore, manually transporting may cause lower back pain or injury. For transport, hang this pump with cargo-handling equipment (such as a mobile crane) or fix it on a pallet and then transport it by pallet truck.</p>
	

1.2.3 Storage



NOTES	<u>Respect the environmental conditions</u>
	<p>This pump has a precise clearance. Confirm the storage location and satisfies the requirements listed in "3.1.2 Storage environment requirements."</p>

▶ 1.3 Installation/Operation

 WARNING	<p><u>Do not remove the face panel</u></p> <p>Never remove the face panel. Failure to observe this instruction may lead to burns or electrical shock.</p>
	
 WARNING	<p><u>Do not remove the casters</u></p> <p>Do not remove the casters, and do not install this pump directly on the ground.</p>
	
 CAUTION	<p><u>Use the unit with a specified amount of oil.</u></p> <p>Be sure to use the unit with a specified amount of oil. If it exceeds the upper limit, oil may blow out from the exhaust port when entering the atmosphere. In addition, if the oil level becomes lower than the lower limit during the operation, the bearings, shaft seals, etc. are damaged, which causes a leakage, abnormal noise, overloaded motor, or shutdown, causing a malfunction. When it is necessary to add oil, use the same oil as that being used.</p>
	





<p>NOTES</p>	<p><u>Do not apply shock to this pump or put in at an incline, position it sideways, or stand it up or reverse it.</u></p>
	<p>Do not apply shock to this pump or put in at an incline, position it sideways, or stand it up or reverse it. Doing so will degrade the pump's operation. Install this pump in a horizontal position to be leveled.</p>
<p>NOTES</p>	<p><u>Operate this pump after its temperature reaches the operational ambient temperature</u></p>
	<p>If this pump has been stored outside the range of the operational ambient temperature, wait for the temperature of the main unit of this pump reaches "3.1.3 Environmental requirements for installation and operation" before operating this pump.</p>
<p>NOTES</p>	<p><u>Install this pump in a horizontal position to be leveled</u></p>
	<p>After moving to the installation location, adjust the four adjusters within the range of 0 to 10 mm and install this pump horizontally on the main unit. If you operate with casters, vibration may be transmitted to the floor. In addition, this pump may move itself and collide with surrounding equipment.</p>

▶ 1.4 Removal

 <p>WARNING</p>	<p><u>When a harmful gas that is dangerous to the human body was exhausted, commission a specialized disposal contractor to dispose of this pump.</u></p>
	<p>When a harmful gas that is dangerous to the human body was exhausted in this pump, be sure to commission a specialized disposal contractor.</p>
<p>NOTES</p>	<p><u>Dispose of oil according to the safety data sheet.</u></p>
	<p>Dispose of oil according to the "Precautions for Disposal" column in the safety data sheet. For the safety data sheet, obtain the latest version from your nearest sales office or agency.</p>

Dispose of this pump according to the laws and ordinances issued by your local government. Particularly if you have used this pump to exhaust harmful gas, ask a waste disposal specialist to dispose of this pump. The customer must incur any disposal-related costs.

▶ 1.5 Protective Device

 <p>WARNING</p>	<p><u>Provide a ground-fault interrupter.</u></p>
	<p>In the event of a short circuit, it protects the equipment and wiring and protects against overload. In addition, it protects against an electric shock and a ground fault that can lead to fire due to electric leakage. If no ground-fault interrupter is installed or if it is installed but does not match the motor capacity, it causes damage to equipment, fire, or an electric shock.</p>
 <p>WARNING</p>	<p><u>Be sure to install an overload protector.</u></p>
	<p>Be sure to install an overload protection device that matches the capacity. If the overload protection device is not installed or does not fit the capacity, it may damage the motor or cause a fire.</p>





This unit has a three-phase current motor. For this motor, no protector is included. Connect the motor to the power supply through an overload protector.

Installation of an overload protection device is made mandatory by the Technical Standards for Electrical Installations.



For selection of an overload protector, refer to "Table 7: List of Wiring and Ratings of Recommended Ground-Fault Interrupters" on page 37. It is recommended to install a protective device (such as a ground-fault interrupter) other than the overload protector.

▶ 1.6 This pump intrinsic hazards and safety measures





1.6.1 Vacuum pumping and exhaust of hazardous gases or substances

	<p><u>Do not exhaust toxic gas, combustion gas, flammable gas, corrosive gas, explosive gas, or gas containing fine powder</u></p>
	<p><u>Wear protective equipment</u> During work such as inspection, wear protective equipment suitable for toxic substances for use.</p>
	<p><u>Ask a waste disposal specialist to dispose of this pump.</u> To dispose of this pump, ask a waste disposal specialist authorized by the government.</p>
	<p><u>Ask for entrust to a specialized processor for detoxification processing.</u> For an overhaul or disposal, entrust a processor specialized in waste disposal to do the detoxification processing.</p>





1.6.2 Transfer of heavy object



	<p><u>Never get under this pump.</u> The pump may fall or topple if a forcible operation is performed or if the equipment is not sufficiently maintained. Never get under this pump.</p>
	<p><u>Certified persons must perform loading work and operate the cargo-handling machine.</u> Never perform loading work or operate the cargo-handling machine if you do not have the appropriate certifications. Failure to observe this instruction may lead to accident or injury.</p>

1.6.3 Electrical shock



	<p><u>Electrical connections should be made after disconnecting the open-circuit device.</u> <u>Before installing electric wiring, turn off the open-circuit device.</u></p> <p>Never leave the voltage applied during the work. - There is the risk of electric shock.</p>
	<p><u>Before inspection/relocation, turn off the open-circuit device and lock (LOTO).</u></p> <p>Before inspection/relocation, be sure to turn off the open-circuit device and lock (LOTO). Never leave the voltage applied during the work. - There is the risk of electric shock.</p>
	<p><u>Be sure to connect the ground terminal.</u></p> <p>A certified electrical worker must embed grounding or connect the ground line. Incomplete grounding incurs the risk of electrical shock.</p>
	<p><u>Be sure to close the lid of the motor terminal box.</u></p> <p>After the completion of wiring to the motor, be sure to close the lid of the terminal box. Never open the lid during operation. There is the risk of electric shock.</p>
	<p><u>Securely tighten the terminal.</u></p> <p>Securely tighten the terminal. Check the tightening condition once a month. In the event of insufficient tightening, the motor terminal block may be burnt.</p>

1.6.4 High temperature







	<p><u>Do not remove the face panel.</u></p> <p>Never remove the face panel. This pump becomes very hot during operation and remains hot for a while after operation stops. Touching it may lead to burns.</p>
	<p><u>Do not touch the pump's main unit, motor, or piping during operation.</u></p> <p>Do not touch the pump's main unit, motor, or piping during operation because they are very hot. Failure to observe this instruction may lead to burns.</p>
	<p><u>Wait until the pump temperature drops.</u></p> <p>The pump is hot immediately after operation stops. Wait a while until the pump temperature drops and then perform inspection. Failure to observe this instruction may lead to burns.</p>
	<p><u>Do not touch the main unit and motor section when using the gas ballast function.</u></p> <p>Do not touch the main unit and motor section when using the gas ballast function. It reaches a high temperature and you may get burned.</p>

 <p>CAUTION</p> 	<p><u>Install the protection cover to the piping.</u></p> <p>The temperature of the inlet/exhaust piping is 70°C or more. After connecting the inlet/exhaust port piping, install the protection cover.</p>
-------------------------------------------------------------------------------------------------------------------------------------------------------------------------------------------	-------------------------------------------------------------------------------------------------------------------------------------------------------------------------------------------------------------



1.6.5 Ruptures

 <p>WARNING</p> 	<p><u>Do not increase the pressure on the pump's exhaust side to 0.03 MPaG or higher.</u></p> <p>Measure the pressure on the pump's exhaust side. If the pressure is 0.03 MPaG (0.3kg/cm²G) (gauge pressure) or higher, remove any objects that prevent gas on the exhaust port side from passing. If the pump's internal pressure exceeds 0.03 MPaG, the pump may rupture.</p>
-------------------------------------------------------------------------------------------------------------------------------------------------------------------------------------------	------------------------------------------------------------------------------------------------------------------------------------------------------------------------------------------------------------------------------------------------------------------------------------------------------------------------------------------------------------------------------------------------

1.6.6 Leakage of high-temperature cooling water

 <p>WARNING</p> 	<p><u>If this pump is operated without water supply, stop immediately and keep away from it</u></p> <p>If this pump is operated without water supply, stop immediately and keep away from it. Hot steam may blast out of the pump's cooling water port.</p>
 <p>WARNING</p> 	<p><u>Install an interlock on the cooling water pathway.</u></p> <p>Install a flowmeter on the cooling water pathway, and install an interlock so that this pump stops if supply of cooling water stops. If you operate this pump without flowing cooling water, hot steam may blast out of the pump's cooling water port.</p>
 <p>WARNING</p> 	<p><u>Wait until the pump temperature drops.</u></p> <p>Remove and inspect after stopping this pump and confirming that the temperature has dropped.</p>

▶ 1.7 Safety Data Sheet

 <p>WARNING</p> 	<p><u>Thoroughly read the safety data sheet</u></p> <p>Obtain the safety data sheet (hereinafter referred to as the "SDS") and thoroughly read it in advance. If lubricant adheres to the skin or enters the eyes, follow the first aid procedure described on the safety data sheet.</p>
<p>NOTES</p> 	<p><u>Use the specified lubricant</u></p> <p>Use of a non-specified lubricant will affect the pump's performance and service life as well as void the pump's warranty coverage.</p>

Do not use any chemical substance (Lubricant) that is not specified on this manual.

Lubricating oil	ULVOIL R-72 (Standard oil)
-----------------	----------------------------

The SDS describes the chemical substances that may be used or touched to operate this pump. To understand the characteristics of hazards, carefully read the SDS. Obtain the latest version of the SDS from our nearest sales office or dealer.

The SDS provides reference information to ensure safe handling of dangerous or hazardous chemical substances.

Anyone handling lubricant must always obtain the latest SDS and understand that measures suitable for the actual handling and other situations in question must be taken under their own responsibility by referring to the SDS before using the lubricant. The SDS itself does not guarantee safety.

2. Product Overview

This pump is a rotary vane single-stage type oil rotary vacuum pump mainly for film formation and heat treatment systems.

Designed for durability and maintainability, it comes with the following functions.

Features

■ Smallest footprint in the class

Compact design of 871 × 404 mm.

■ Mechanical booster pump (MBP) allowed to be directly mounted

Installing an MBP mount kit allows you to directly mount an MBP without a base.

■ Built-in oil mist separators

This removes oil mist contained in exhaust gas. An oil recovery mechanism is also built in to return oil caught by the filter to the pump.

■ Oil leak seldom structure outside the pump.

An oil leak seldom structure outside the pump with two stages of oil seal and shield bearing.

■ ULVAC's original IE3 high-efficiency multi-voltage motor installed

A wide range of voltages are supported with a single motor.

■ Adoption of a check valve

A check valve is provided as standard at the inlet port. The check valve has a function to prevent oil from flowing into the vacuum chamber and prevent oil from returning to the vacuum chamber when the pump is stopped.

■ Automatic pressure recovery mechanism

If the pump is stopped for a long time after a sudden power failure or with the inlet side not returned to the atmospheric pressure, oil may flow back into the cylinder and the pump may become difficult to restart.

A mechanism is provided to return the inside of the cylinder to the atmospheric pressure to prevent an oil backflow and to reduce the load at the restart of the pump.

■ Adoption of vane material with high shape stability

The vane is made of material with less swelling due to moisture absorption or, little thermal deformation or thermal change in size.

■ Adoption of highly durable exhaust valve material

A highly durable exhaust valve has been adopted by employing new material and reducing bending stress.

■ Thermostat adopted as standard

An abnormal temperature rise of the pump due to a decrease in oil circulation amount or performance deterioration can be detected.

■ Improvement in maintainability

The oil tank with a capacity of up to 15L has a large opening for easy access for cleaning.

The oil mist separators can be replaced easily. Daily check (oil level check, oil replenishment, oil change). The surfaces faces in the same direction.

▶ 2.1 Application Purpose

- Optical film deposition system
- Thin film deposition system for reflector
- Evaporation system for decorative moldings
- Evaporation Roll coater systems
- In-line sputtering systems
- Vacuum Heat Treatment / Bake Furnace systems
- Vacuum Freeze drying systems
- Vacuum leak testers
- Space chambers
- Other equipment, evacuation system

▶ 2.2 Principles of Pumping

In this pump three vanes are attached to a rotor installed inside the cylinder, and these vanes divide the inside of the cylinder into three spaces. Gas in the divided spaces is compressed with the rotation of the rotor, changes periodically, and is discharged to the atmosphere through the exhaust valve. Oil plays a role of cooling and sealing to enhance the airtightness of the vanes and cylinder.

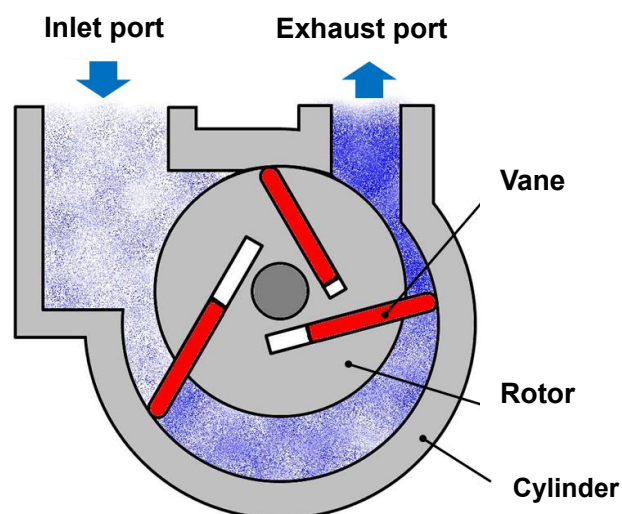

Figure 1: Cross section of the inside of the cylinder

▶ 2.3 Performance Curve

2.3.1 Ultimate pressure

"Ultimate pressure" described in the catalog and the body text means "the limit pressure that can be obtained by the pump without introducing gas from the inlet port of the pump (no-load operation)." We use the specified vacuum pump oil and, after completely cutting off the equipment, connect a Pirani gauge only to the inlet port of the pump for measurement. For an actual vacuum unit, the location where the vacuum gauge is installed is far from the pump and, due to the effect of water vapor and various gases generated from water droplets, rust, and other deposits that adhere to the inner wall of the unit, piping, or other parts, the ultimate pressure becomes higher than the catalog value. This is because the volatile gas dissolved in the pump oil or foreign substances or gases sucked into the pump from the vacuum chamber contaminate the vacuum gauge head or decompose (deteriorate) the components of the pump oil, increasing the oil vapor pressure.

2.3.2 Pumping speed

The pumping speed of an oil rotary vacuum pump depends on the type and pressure of the gas to be drawn in. A high pressure region provides the maximum pumping speed and, as the pressure decreases, the pumping speed gradually decreases. The effective pumping speed of this unit indicates the maximum value when dry air is drawn in.

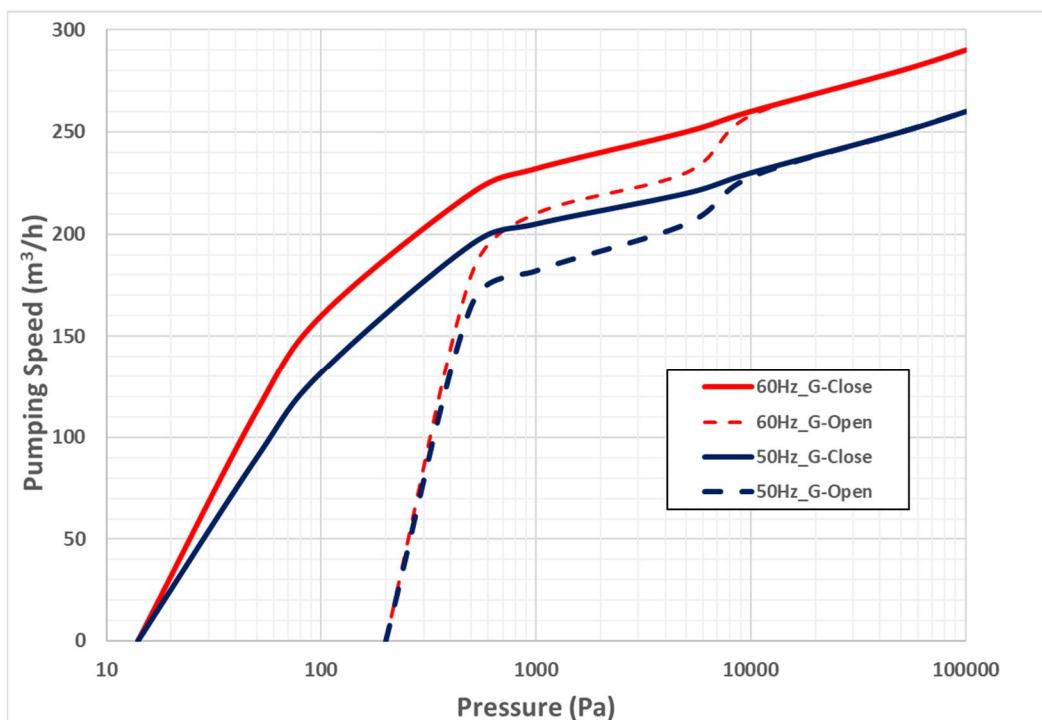

Figure 2: Pumping speed curve

2.3.3 Power consumption

The power for driving a vacuum pump is the sum of the work (mechanical work) against the rotational friction of mechanical elements and the work (compression work) that compresses the air, providing the maximum suction pressure between 2×10^4 and 6×10^4 Pa. At a pressure of 10 Pa or less, the compression work is a little and most of the power is spent on the machine. The pressure range with the maximum load is the suction pressure range of 2×10^4 to 6×10^4 Pa.

When operating with the gas ballast valve open, a large amount of power is required at all times even at a low suction pressure.

In addition, when the temperature of the pump installation location is low (such as in a cold area and an outdoor area in winter), the temperature of the pump oil is low in temperature and high in viscosity, requiring a large amount of power especially at startup. However, the pump temperature gradually increases as the operating time passes, which decreases the oil viscosity, reducing the power value for a stable condition.

The motor with the specifications described in "**Table 7: List of Wiring and Ratings of Recommended Ground-Fault Interrupters**" on page 37 is a motor with the power characteristics required to operate the pump in consideration of the above.

▶ 2.4 Name and Function of Parts

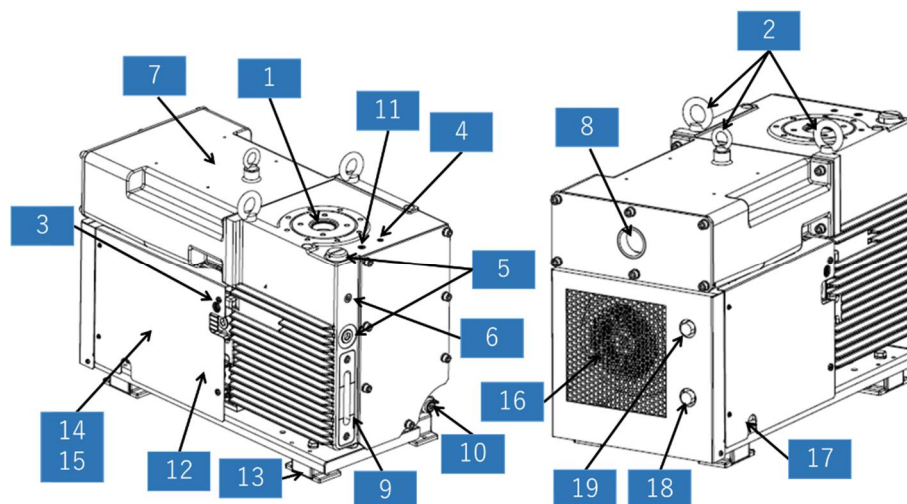

Figure 3: Name of parts

Table 1: Name of Parts

Name		Function	Reference
1	Inlet port	Connect the container and piping for evacuation. (DN63 ISO-F)	3.6.1
2	Eyebolt	Used when hoisting this unit using a crane. Be sure to use all three.	3.3.1
3	Manual gas ballast valve (inner)	Used when supplying gas ballast gas.	3.6.4
4	Pressure gauge mounting port	Used when installing a pressure gauge. (G1/4)	6.2.4
5	Filler Port (2 places)	Used when supplying oil. (G1)	3.5
6	External filter port	This is the port to return oil from the external filter. (G1/2)	-
7	Oil mist separator unit (Inner)	Oil is separated from the gas exhausted by the pump.	3.6.2 /6.2.4
8	Exhaust port (horizontal)	Connect the pipe that discharges the exhaust gas. (G2)	3.6.1
9	Oil level gauge	Check the amount of oil.	3.5
10	Oil drain port (Drain valve)	The valve used to discharge oil. (Rc1/2)	6.2.10
11	Purge gas port	Connect the pipe that supplies a purge gas. (G3/8)	3.6.6
12	Oil filter (inner)	Remove impurities contained in oil that circulates in the pump.	6.2.8
13	Vibration-proof rubbers	Vibration transmitted to the ground is reduced. Castor models are also available as options.	3.4 /3.4.1
14	Motor connection part (inner)	Used when installing electrical wiring to the motor.	3.7.1
15	24 VDC power connection part (inner)	The thermostat wire is connected to the terminal block.	3.7.2
16	Ventilation port	Draw in air to cool oil.	3.4
17	Wire exit port	The place to draw out the motor wiring.	3.7.1
18	Cooling water inlet	Connects the pipe that supplies cooling water. (G1/2)	3.6.3
19	Cooling water outlet	Connects the pipe that discharges cooling water. (G1/2)	3.6.3

▶ 2.5 System Configuration

Perform the direct-connect starting of this pump. For the power capacity required for the direct-connect starting of 200 VAC / 400 VAC, refer to "Table 7: List of Wiring and Ratings of Recommended Ground-Fault Interrupters" on page 37.

● VS300A-W

The cooling water and power supply are required as utilities.

The cooling water enters through the cooling water inlet of the panel, circulates through the heat exchanger, and discharges through the cooling water outlet. It is recommended to provide a flowmeter in the cooling water system and provide an interlock that stops the pump when the amount of water becomes lower than the specified value.

When using water with a large amount of impurities, such as scale and iron, filter them with a filter installed in the prior stage before use.

The open-circuit device of this pump is an overload protector. Install this open-circuit device within easy reach. Also indicate that it is an open-circuit device for the pump.

The area surrounded by the broken line below falls within the customer's responsibility. Customers are responsible for preparing and managing these pipes, wires, and pieces of equipment.

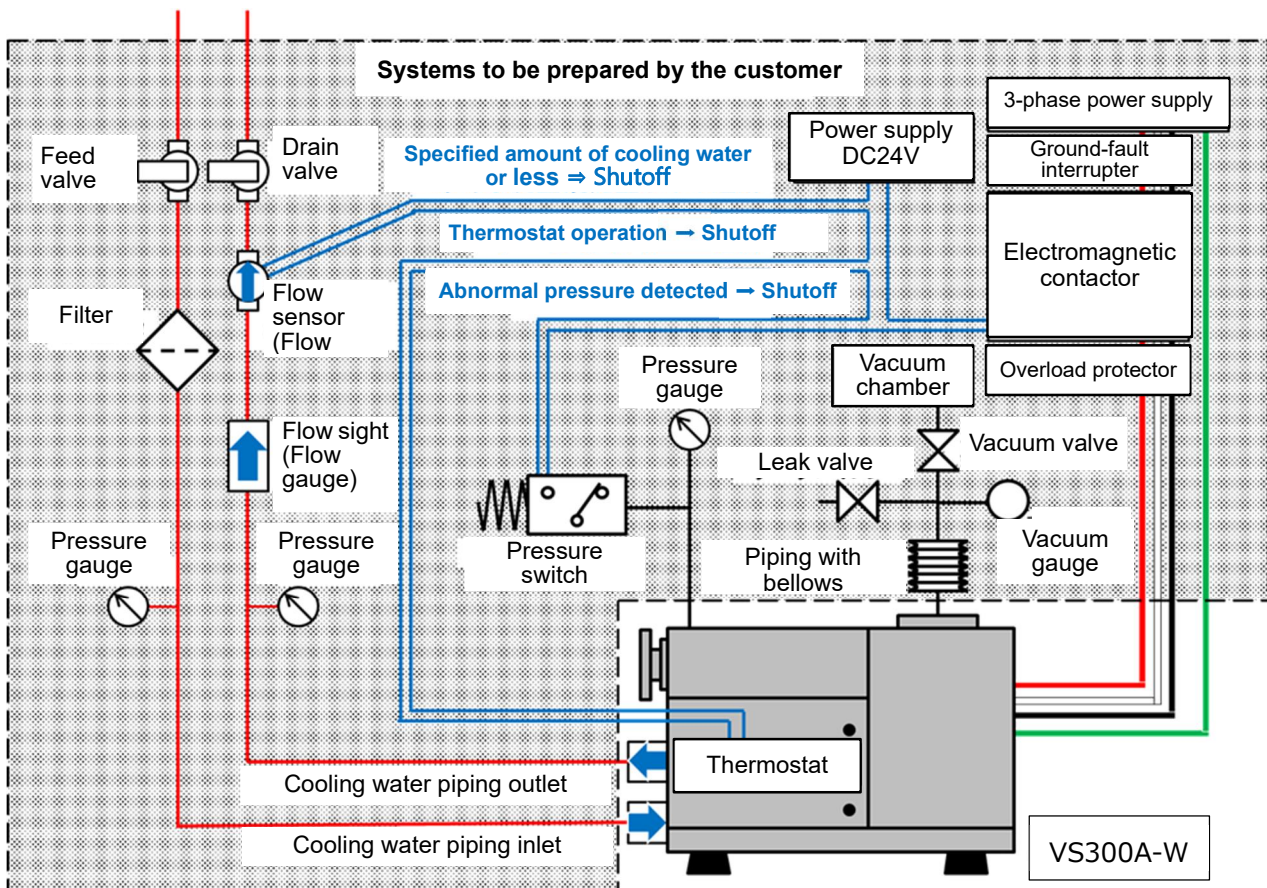

Figure 4: System connection diagram

NOTES

The warranty covers this pump only (refer to "Warranty Scope"). Note that any failures and damage due to piping, wiring, or equipment within the customer's responsibility mentioned above are not covered by the warranty.

3. Installation

▶ 3.1 Before Installation

3.1.1 Responsibility for work from shipping to startup

This pump is provided on the assumption that we are in charge of the stages from packing through shipment (transport), while the customer is in charge of the stages from cargo reception through startup. However, the customer may fully or partly transport, unpack, or install this pump depending on the pump's terms and conditions.

Packing	•ULVAC
↓	
Transport	•ULVAC entrust this task to a specified carrier.
↓	
Cargo reception and unpacking	•Customer
↓	
Inspection	•Customer
↓	
Transfer to the installation location	•Customer
↓	
Installation and assembly	•Customer
↓	
Piping and wiring	•Customer
↓	
Startup check	•Customer

NOTES	The above work from shipment to startup may not apply in your case. Check the pump's specifications manual. If you have any questions, please contact us.
--------------	------------------------------------------------------------------------------------------------------------------------------------------------------------------

3.1.2 Storage environment requirements

Store into following conditions when this pump will be stored at warehouse or clean storage room prior to installation without use for a long period of time.

Ambient temperature	-15 to 60°C (No freezing)
Ambient humidity	95 %RH or less (No condensation)
Altitude	1,000m or less of altitude above sea level
Vibration resistance	Vibration acceleration of 0.5G (114dB) or less
Others	No dust
	The room must be ventilated.
	Do not stack this pump, position this pump sideways, or stand it up.
	Do not apply shock to this pump.
	Do not expose this pump to direct sunlight.
	Keep this pump away from heat sources.
	Be sure to release the water in the cooling water piping before storage. In low temperatures (0°C or less), parts may be damaged by frozen water.
Do not incline this pump by 10 degrees or more.	

3.1.3 Environmental requirements for installation and operation











This pump is a unit with precise clearances. Confirm that the following requirements are satisfied during installation and operation.

Ambient temperature · Inhaled gas temperature	10 to 40°C (Inhaled gas temperature is shown in terms of atmospheric pressure.)
Ambient humidity	80 %RH or less (No condensation)
Altitude	1,000m or less of altitude above sea level
Vibration resistance	Vibration acceleration of 0.5G (114dB) or less
Others	No corrosive or explosive gas.
	No dust
	The room must be ventilated.
	Do not stack this pump, position this pump sideways, or stand it up.
	Do not apply shock to this pump.
	Do not expose this pump to direct sunlight.
	Keep this pump away from heat sources.
	After moving to the installation location, adjust the four adjusters within the range of 0 to 10mm and install this pump in a horizontal position.
	Securely fix this pump in case of an earthquake.
Do not incline this pump by 10 degrees or more.	

▶ 3.2 Unpacking

This pump is protected by stretch film, cushioning materials, or by other means, packed in a wooden frame or cardboard, and shipped. In case the packaging is by crate, ask a specialist to dismantle. Provide following precautions and instructions to the dismantling contractor.

3.2.1 Precautions for unpacking

 	<p><u>Never get under this pump.</u></p> <p>This pump may fall or topple if a forcible operation is performed or if the equipment is not sufficiently maintained.</p>
 	<p><u>Cargo handling work and operation of cargo handling machines shall be performed only by qualified personnel.</u></p> <p>Cargo handling work and operation of cargo handling machines shall be performed only by qualified personnel.</p>
 	<p><u>Lift using cargo handling equipment.</u></p> <p>Give instructions to hoist and transfer this pump using a crane or other cargo-handling equipment with eyebolts on the top of this pump when unpacking or hoisting it.</p>
 	<p><u>Do not incline this pump by 10 or more.</u></p> <p>Otherwise, this pump may topple, causing injury or damage.</p>
 	<p><u>For crate packing, wear leather gloves and use appropriate dismantling tools.</u></p> <p>As you may cut your hands with a nail used to fix the crate or a piece of wood during work, give instructions to wear leather gloves and use appropriate dismantling tools, such as an appropriate crowbar.</p>

3.2.2 Confirmation after unpacking

After unpacking, confirm that this product matches your order and has not been damaged in transit or for another reason.

If you notify us of a packing problem after starting use, we may charge for a repair.

Although we ship with the greatest care, after unpacking, confirm the following to ensure safety.









- Check if the actual content match with your order.
- Check if accessories (Quick manual, optional parts) are included.
- Check if there are any parts damaged during transportation.
- Check that there is no any screws and nuts loosened or disconnected during transportation.

In the event of any failure, contact our sales department or specified agent.







Table 2: List of standard accessories

Product name	Specifications	Q'ty	Remarks
A fill of oil	ULVOIL R-72	1	For the usage, refer to the specification table.
Quick manual	Japanese version, English version	1	—

▶ 3.3 Transfer

 WARNING 	<p><u>Do not use the casters as a transportation device or a means of equipment support.</u></p> <p>Although this pump is equipped with casters, do not use them as a transportation device or a means of equipment support.</p>
 WARNING 	<p><u>Do not incline this pump by 10 or more.</u></p> <p>Otherwise, this pump may topple, causing injury or damage.</p>
 WARNING 	<p><u>For transport, use cargo-handling equipment (e.g., a mobile crane) or a pallet truck.</u></p> <p>The weight of machine is as follows: VS300A-W: 270kg To transport this pump, a load higher than the safety standards is required. Therefore, manually transporting it may cause lower back pain or injury.</p>
 WARNING 	<p><u>Wear safety shoes during transportation</u></p> <p>Be sure to wear safety shoes before transferring this pump.</p>

3.3.1 How to hoist using crane

 DANGER 	<p><u>Never get under this pump</u></p> <p>This pump may fall or topple if a forcible operation is performed or if the equipment is not sufficiently maintained. Never get under this pump.</p>
 WARNING 	<p><u>Use a crane or other cargo-handling equipment</u></p> <p>Give instructions to lift and transfer this pump using a crane or other cargo-handling equipment securely with the three eyebolts on the top of this pump when unpacking or lifting it. Before using eyebolts, confirm that there are no abnormalities. When hoist, make sure that hoist angle formed by the diagonal lines of the hoisting attachments with 60 degrees or less.</p>
 WARNING 	<p><u>Certified persons must perform loading work and operate the cargo-handling machine.</u></p> <p>Never perform loading work or operate the cargo-handling machine if you do not have the appropriate certifications. There is a risk of accident or injury.</p>

1. Prepare an appropriate hoisting attachment and check that the eyebolts are in normal condition (e.g., not loosened or damaged).
2. Hook the hoisting attachments on the three eyebolts of this pump and hook them on the hook of the crane.

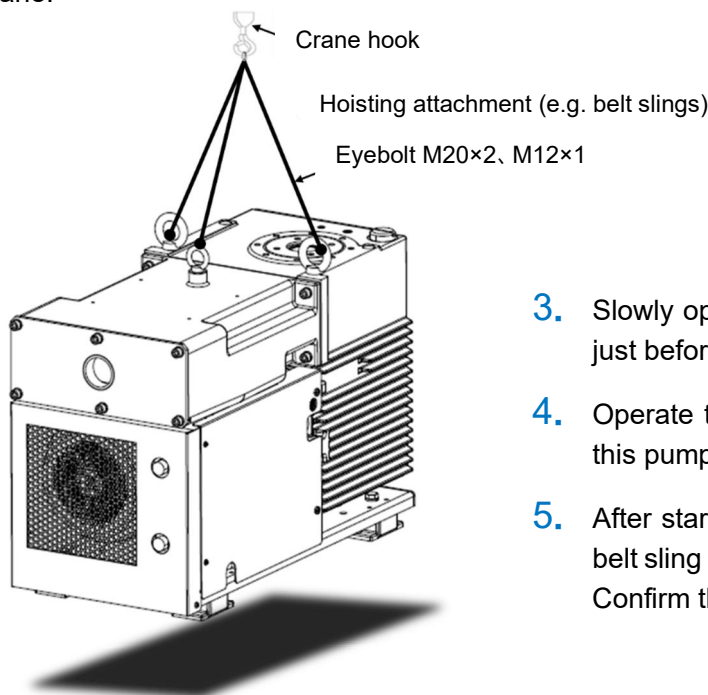

Figure 5: Hoisting using crane

3. Slowly operate the crane to hoist this pump until just before this pump leaves the ground.
4. Operate the crane again to hoist this pump until this pump leaves the ground.
5. After starting to hoist this pump, confirm that the belt sling and hoisting tool are in normal condition. Confirm that the load is not inclined.
6. When unloading the machine, make sure to lower the crane slowly not to apply shock to or damage the machine.

3.3.2 How to transport using pallet truck



WARNING



Do not transport this pump with the adjusters raised

When transporting this pump via pallet truck, lower the four adjusters. If you carry this pump without the adjusters attached to the pallet, the machine may topple, causing injury or damage.

1. When putting this pump on a pallet, lower the adjusters (4 places).

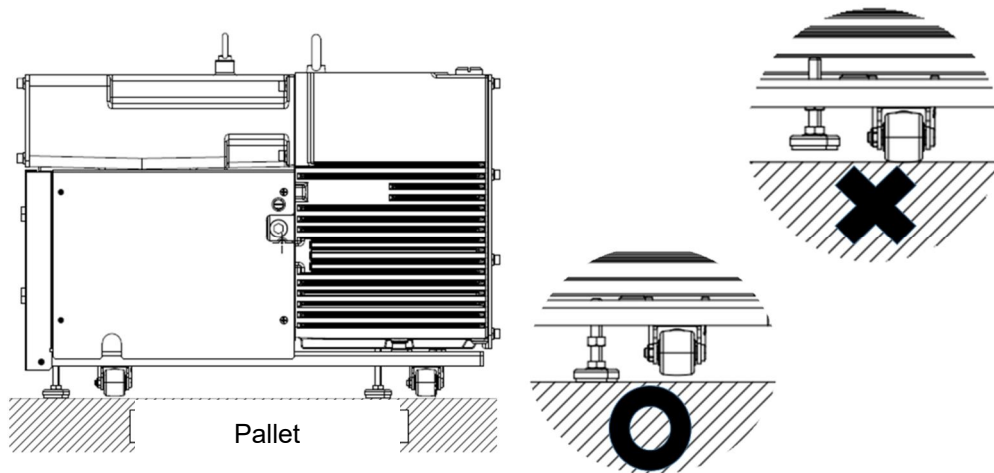

Figure 6: Adjusters in transportation

2. Put the pallet truck's fork through the pallet and lift the pallet slowly.
3. Transport the machine after confirming that there are no obstacles in the direction of travel.

When transporting the unit with a pallet truck or forklift without using a pallet, be sure to insert the fork from the front or back. If it is inserted from the side, it may tip over.

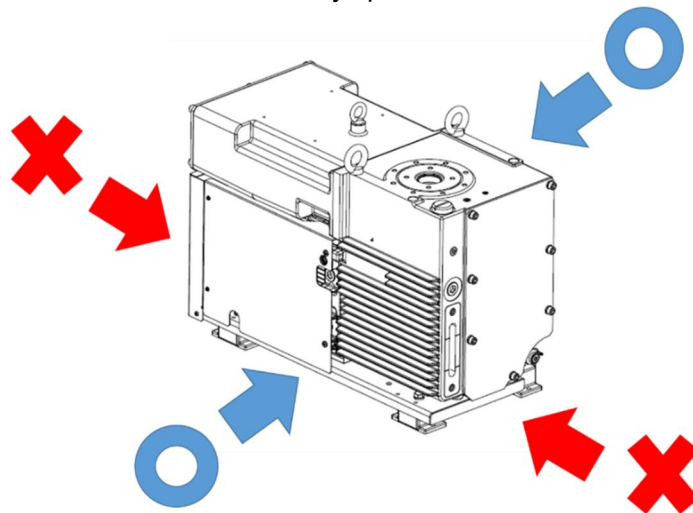











Figure 7: Fork insertion direction

▶ 3.4 Installation

Arrange this unit in consideration of work, such as installation, removal, inspection, and cleaning, and release of exhaust gas to the outside. Install this unit in a horizontal position and fix it using vibration-proof rubbers to prevent looseness.

 <p>DANGER</p> 	<p><u>Before installation or removal work, disconnect this unit from all energy sources.</u></p> <p>Before installation or removal work, disconnect this unit from all energy sources (such as electricity, compressed air, and cooling water). * If you are using compressed air, nitrogen gas, or other gases, remove it.</p>
 <p>WARNING</p> 	<p><u>Comply with Rules and Laws and Regulations</u></p> <p>Install and operate this pump in compliance with the safety codes and laws (e.g. fire protection laws and electric codes) in the country and region where you use this pump.</p>
 <p>WARNING</p> 	<p><u>Do not Remove the Casters</u></p> <p>Do not remove the casters during installation or place them directly on the ground. The ventilation holes at the bottom of the pump may be blocked, resulting in burns or fire due to abnormal overheating</p>
 <p>WARNING</p> 	<p><u>Never place flammables within 1 m around the motor and vacuum pump.</u></p> <p>Never place flammables within 1 m around the motor and vacuum pump. There is a risk of fire.</p>
 <p>WARNING</p> 	<p><u>Do not place walls or obstacles within 0.7 m from the ventilation port of the motor.</u></p> <p>Do not place walls or obstacles within 0.7 m from the ventilation port of the motor (at the end of the motor). There is a risk of burn injury and fire due to abnormal overheating.</p>

3.4.1 Leveling (For Optional Caster Models)

NOTES	<u>Install this pump in a horizontal position</u>
	After moving to the installation location, adjust the four adjusters within the range of 1 to 10 mm and install this pump horizontally on G.L. If you operate it with casters, vibration is transmitted to the floor. In addition, this pump may move itself and collide with surrounding equipment.

After moving this pump to the installation location, use the adjuster to adjust the machine's inclination and install it. (Adjustment range is within +10mm). Use the adjustment while checking the inclination with a level if necessary. After adjusting the adjusters, fix it with hexagon nuts.

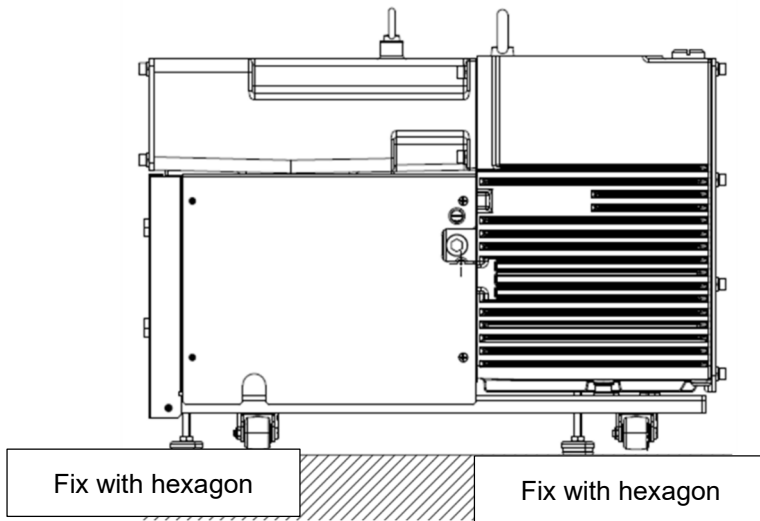



Figure 8: Adjusters in Installation

3.4.2 Earthquake countermeasures

As an earthquake countermeasure, fixing brackets are available as an option.

NOTES	<u>Perform earthquake resistant fixing</u>
	Securely fix this pump in case of an earthquake. If the machine is fixed insufficiently, it may topple or move, damaging the surrounding equipment.
NOTES	<u>Piping and wiring need to be structured to absorb shaking.</u>
	Vacuum piping, cooling water piping, purge gas piping, and electric wiring need to be structured to absorb shaking. This is to prevent braking or disconnection of piping by the shaking.

Earthquake resistance has been examined based on the requirements of the 1997 Edition of the United States Union Building Code (UBC).

For the overturning moment, horizontal load and center-of-gravity position, refer to "Table 3: Earthquake resistance assessment."

※Customers are required to prepare the Earthquake-resistant fixing bracket when pump is caster type.

Date: February 2022

Table 3: Earthquake resistance assessments

		Unit	VS300
Whole width of the surface of projection that falls easily	L1	mm	404
Short distance from the fulcrum on the surface of projection that falls easily to the position of the center of gravity	L2	mm	210
Distance from the rear panel to the position of the center of gravity	L3	mm	435
Height from the floor to the center of gravity	h	mm	276
Weight of equipment	Wp	kg	270
Horizontal moment (adjuster bolt) $F_p = 0.94 \times W_p$	Fp/4	kg	63.5
There is overturning moment R when $0.94 \cdot h \geq 0.85 \cdot L2$.			OK
Overturning moment $R = (W_p \cdot (0.94h - 0.85L2)) / (2 \cdot L1)$	R	kg	27.0
Shear stress of anchor bolt (M8 × 2)	τ	N	1531
	$F_p < \tau$		OK
Tensile stress of anchor bolt (M8 × 2)	σ	N	2653
	$R < \sigma$		OK
Interval between adjuster bolts	J1	mm	312
Interval between earthquake-resistant brackets	J3	mm	312
Tipping angle	$\alpha 1$	deg	29.5
Interval between earthquake-resistant brackets	J2	mm	735
Tipping angle	$\alpha 2$	deg	53.1
	$\alpha > 15 \text{deg}$		OK

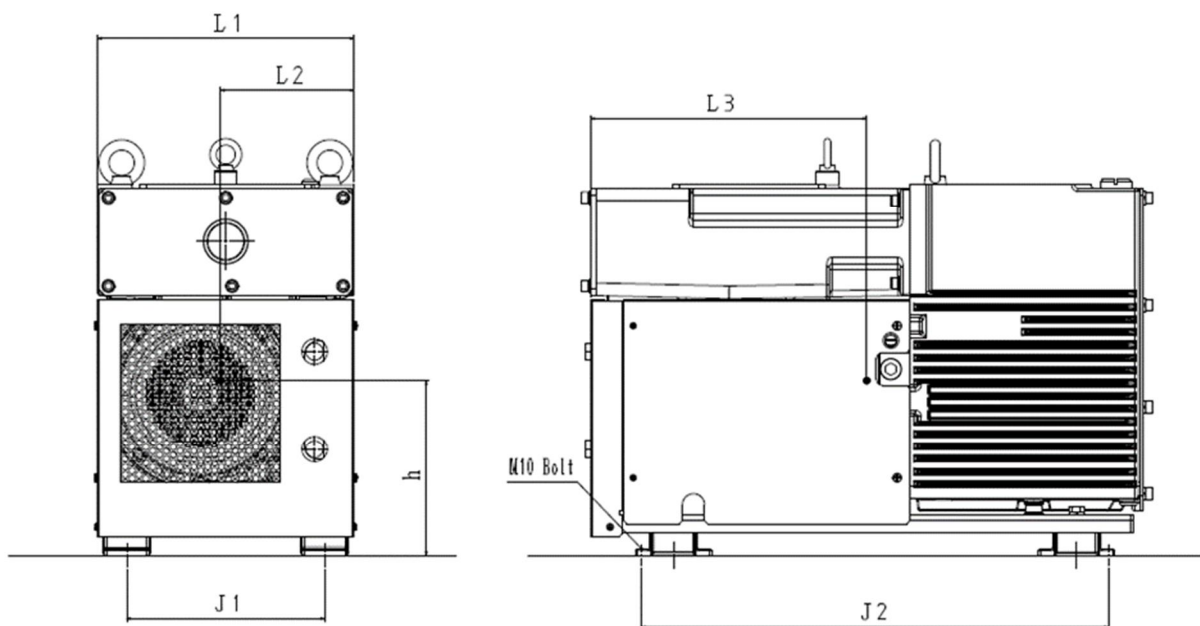





▶ 3.5 Oil Filling

Use the oil specified by us.

In reference to "**Figure 9: Oil filler port and oil level gauge position**" and "**Figure 10: Specified oil level**" on page 25, add oil so that the oil level is at the "MAX." level line of the oil level gauge. The pump can operate when the oil level is between the level lines of the oil level gauge during operation.

* The oil level is defined as "the oil level during pump operation."



 DANGER 	<p><u>Wear protective equipment.</u></p> <p>During work such as inspection, wear protective equipment suitable for toxic substances for use.</p>
 WARNING 	<p><u>Thoroughly read the SDS.</u></p> <p>Obtain the SDS and thoroughly read it in advance. If oil comes into contact with your skin or eyes, follow the SDS's first aid section.</p>
<p>NOTES</p> 	<p><u>Use the specified oil.</u></p> <p>The use of any oil other than the specified ones affects the performance and life of this pump, which is not covered by the warranty.</p>

Use the oil specified by us.

Lubricating oil	ULVOIL R-72 (Standard oil)
-----------------	----------------------------

MEMO

- If the pump does not work due to a low ambient temperature, warm up oil or jog the pump several times (short-time ON/OFF operation, inching operation) to start it. If the pump unit rotates for a few seconds and then stops, continue operation can be performed in some cases by opening the leak valve and starting while performing a slow leak. When the pump is warmed up, close the leak valve and return to the normal operation.
- If the pump needs to be frequently jogged, warm up oil before starting.

<p>CAUTION</p>  	<p><u>Use the unit with a specified amount of oil.</u></p> <p>Be sure to use the unit with a specified amount of oil. If it exceeds the upper limit, oil may blow out from the exhaust port when entering the atmosphere. In addition, if the oil level becomes lower than the lower limit during the operation, the bearings, shaft seals, etc. are damaged, which causes a leakage, abnormal noise, overloaded motor, or shutdown, causing a malfunction. When it is necessary to add oil, use the same oil as that being used.</p> <p>* For the amount of oil, refer to "8.1 Performance Specifications" on page 69.</p>
<p>NOTES</p> 	<p><u>Do not start with the oil level at the lower limit.</u></p> <p>Do not start with the oil level at the lower limit. Starting below the lower limit may cause failures.</p>

 MEMO

- It takes approx. 1 minute for oil to spread out. After the oil level becomes stable, operate the unit for a few seconds once. Operating the unit lowers the oil level. This is because oil circulates in the main unit, oil cooler, and other section during operation. Check during operation whether or not the oil level is between the level lines of the oil gauge.
- The oil level may drop when oil is added and the unit is operated during an overhaul or after being stopped for a long period of time with oil removed. In that case, add oil while checking the oil level gauge so that the oil level reaches the specified amount.

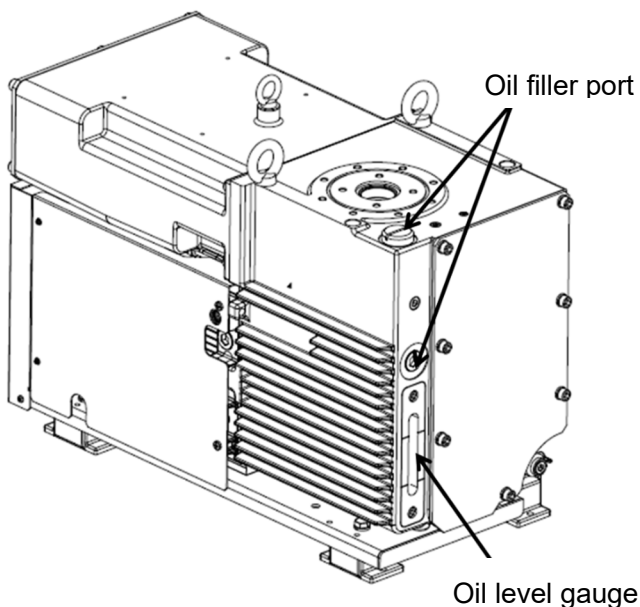

Figure 9: Oil filler port and oil level gauge position

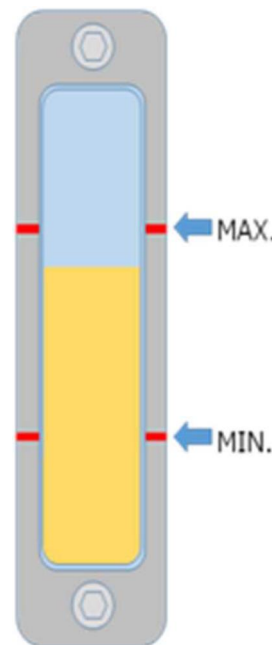













Figure 10: Specified oil level

▶ 3.6 Piping and wiring

 WARNING 	<p><u>Shut off hazardous energy sources.</u></p> <p>Before working on piping and wiring, make sure that all hazardous energy sources are shut off referring to "1. For Safe Use" before starting work.</p>
 CAUTION 	<p><u>Install the protection cover to the piping.</u></p> <p>The temperature of the inlet/exhaust piping is 70°C or more. After connecting the inlet/exhaust port piping, install the protection cover. * Customers are responsible for preparing the protective cover.</p>
 CAUTION 	<p><u>After the temperature of the pump decreases, remove the protective cover.</u></p> <p>The temperature of the inlet/exhaust port piping is 70°C or more. Make sure that the temperature of the pump has decreased and then remove the protective cover.</p>
NOTES 	<p><u>Piping and wiring need to be structured to absorb shaking.</u></p> <p>Vacuum piping, cooling water piping, purge gas piping, and electric wiring need to be structured to absorb shaking. This is to prevent braking or disconnection of piping by the shaking.</p>
NOTES 	<p><u>Take care not to damage the gasket and the sheet surface of the gasket.</u></p> <p>Take care not to damage the gasket and the sheet surface of the gasket. After assembling the pipes, perform a leak test for the entire system.</p>
NOTES 	<p><u>Do not allow foreign matters to enter the inlet/exhaust port of this pump.</u></p> <p>When connecting the pipes, take care not to drop foreign matter (e.g. bolts) into the inlet/exhaust port of this pump. If foreign matters drop, it is necessary to disassemble this pump and remove them. Contact your nearest service center.</p>
NOTES 	<p><u>Do not apply loads directly to the inlet/exhaust port of this pump.</u></p> <p>Do not apply loads, such as the connection piping, directly to the inlet/exhaust port of this pump.</p>
NOTES 	<p><u>Use piping with sufficient pressure resistance.</u></p> <p>If the exhaust piping consists of thin metal pipes, such as accordion type and bellows, the piping may resonate due to exhaust pulsation, causing the noise to exceed the work environment reference value. Use piping with sufficient compressive strength.</p>
NOTES 	<p><u>Take care not to allow foreign matter to mix.</u></p> <p>If the pump sucks solids, such as dust and fine powder, or water, not only the ultimate pressure gets worse but also it may cause a failure. The inside of the pump is designed to rotate with a slight clearance and, if foreign matter enters the pump, it may become unable to rotate.</p>

■ Applicable Piping

- Piping according to the safety rules and laws and regulations in the country of destination.
- Materials that does not rust inside.
- Heatproof temperature of 100°C or more.

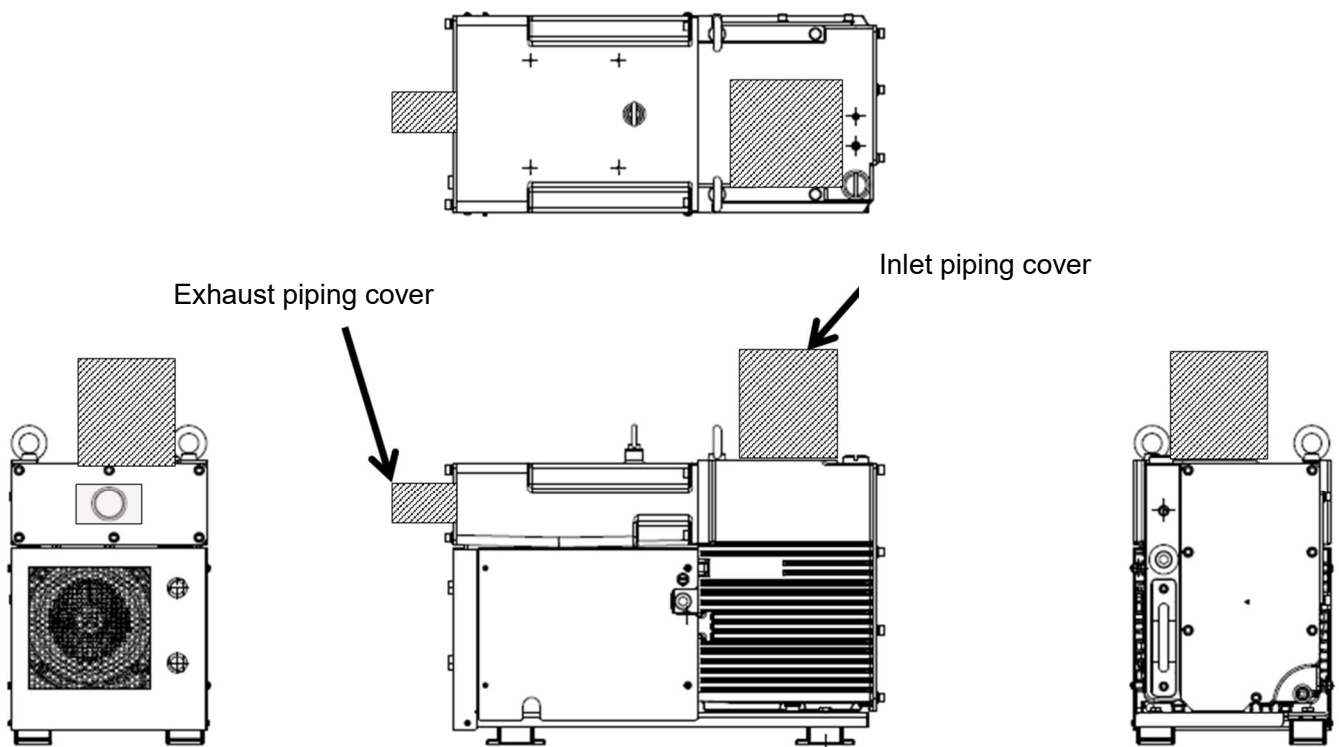









Figure 11: Sample installation of protection cover

3.6.1 Inlet/Exhaust port piping

 DANGER 	<p><u>Be sure to use conductive material for the exhaust port piping and ground it.</u></p> <p>Be sure to use conductive material (which conducts electricity) and ground it when installing the piping of the exhaust port. If non-conductive material is used, static electricity is generated when the exhaust gas passes through, which may cause explosion or fire.</p>
 WARNING 	<p><u>Do not increase the pressure on the pump's exhaust side to 0.03 MPaG or higher.</u></p> <p>Measure the pressure on the pump's exhaust side. If the pressure is 0.03 MPaG (0.3kg/cm²G) (gauge pressure) or higher, remove any objects that prevent gas on the exhaust port side from passing. If the pump's internal pressure exceeds 0.03 MPaG, the pump may rupture.</p>
NOTES 	<p><u>When connecting the pipe, remove the storage flange.</u></p> <p>At the time of shipment from the factory of the VS-series, a storage flange, inlet port mesh, and desiccants are attached to the inlet flange section. When connecting the pipe, remove the storage flange and also the desiccants.</p>
NOTES 	<p><u>Do not remove the wire mesh attached to the inlet port.</u></p> <p>The wire mesh attached to the inlet port is provided to prevent foreign matters from entering the pump unit. Do not remove it unless it is necessary to check it.</p>
NOTES 	<p><u>Use piping with bellows for the inlet piping (Recommended).</u></p> <p>Connect between the inlet port of the pump and the piping with pipes larger than the size of the inlet port. It is recommended to install piping with bellows to prevent vibrations of the pump from being transmitted to the vacuum chamber.</p>
NOTES 	<p><u>The configuration is such that the condensed gas does not return directly to this unit.</u></p> <p>For the configuration, bend sideways the piping on the exhaust port side using an L-shaped pipe or by other means so that the condensed gas does not return directly to this unit. It is recommended to provide a mechanism to drain accumulated liquid.</p>

- Install a vacuum valve, vacuum gauge, and leak valve between the vacuum chamber and the pump. Refer to "Figure 4: System connection diagram" on page 14. Install the leak valve as close to the vacuum chamber as possible to prevent backflow of oil into the vacuum chamber when the pump is stopped.
- Sufficiently clean the inside of the vacuum chamber, pipes, vacuum valves, and other components before connecting them to the pump. If they are contaminated and connected as they are, the ultimate pressure increases or it takes longer to reduce pressure down to the specified pressure. Do not touch vacuum sections with your bare hands, but with gloves.

- When connecting the pipes, take care not to drop foreign matter (e.g. bolts) into the inlet/exhaust port of this pump. If foreign matters drop, it is necessary to disassemble this pump and remove them. Contact your nearest service center.
- Do not apply loads, such as the connection piping, directly to the inlet/exhaust port of this pump.
- Be careful not to damage the seat surface of the O-ring at inlet/exhaust port side. After assembling the pipes, perform a leak test for the entire system.
- If the exhaust piping consists of thin metal pipes, such as accordion type and bellows, the piping may resonate due to exhaust pulsation, causing the noise to exceed the work environment reference value. Use piping with sufficient compressive strength.
- Secure the pipe diameter, path, and flow rate so that the exhaust piping is lower than the allowable pressure.
In addition, the exhaust piping should be able to pass through without exceeding the allowable pressure (0.03 MpaG) on the exhaust side with respect to the maximum flow rate (300m³/hr).

Table 4: Inlet/Exhaust port diameter

Inlet port	DN63 ISO-F
Exhaust port	G2 female

3.6.2 Oil mist separator

This pump comes equipped with oil mist separators as standard. The oil mist separators separate oil from the gas discharged from the pump. Oil smoke can be removed approx. 90% through oil mist separators. Replace the oil mist separators when they are clogged. The limit value of the internal pressure of the pump is 0.03MPaG. Measure the pressure on the exhaust side and, if it is 0.03MPaG or more, replace the oil mist separators. If the clogged condition gets extremely worse, the exhaust gas cannot pass through the oil mist separators, which may cause the main unit of this pump and the oil level gauge to burst or the motor to be overloaded.

To check the internal pressure of the pump, it is recommended to install a pressure gauge and a pressure switch on the oil tank in reference to "6.2.4 Inspection and replacement of oil mist separators" on page 55.

NOTES





Use oil mist separators supported by this pump.

Use our oil mist separators that fits to this pump. If an incompatible oil mist separator is used, the internal pressure of this pump increases and which may cause the main unit of this pump and the oil level gauge to burst or the motor to be overloaded.

MEMO

- During continuous operation at high suction pressures or a continuous exhaust process of hot gas, the temperature of the pump increases, causing the oil to become sludge and easily clog the oil mist separators.
- Continuous operation under the above pump operating conditions generates a large amount of oil smoke even if oil is not degraded. In this case as well, the clogging of the oil mist separators is likely to occur.

3.6.3 Cooling water piping

NOTES	<u>Use appropriate joints.</u>
	The cooling water port of this pump is G1/2. Connect appropriate joints to the cooling water piping. Do not confuse between inlet cooling water port and the outlet cooling water port.
NOTES	<u>Items to comply with in the use of cooling water piping.</u>
	Comply with the items described below for cooling water and piping.

● **Be sure to supply the required amount of cooling water.**

Especially during operation at a high suction-pressure, if the amount of water falls below the specified amount, the temperature of this pump increases the pump malfunctions. It is recommended to install a flowmeter in the cooling water system and provide an interlock that stops this pump when the amount of water becomes equal to or lower than the specified value.

● **When stopping the operation in winter, drain water inside.**

When operation is stopped in winter, water in the cooling water piping may freeze, causing damage to them. While operation is stopped, drain water inside by blowing compressed air from the cooling water outlet or by other means.

● **It is recommended to use water with fewer impurities (e.g. industrial water; refer to the table below) for cooling water.**

It is recommended to use water with fewer impurities (e.g. industrial water; refer to the table below) for cooling water of this pump. It is recommended to use "Table 5 [for reference]: The standard quality of water supply in the Japanese industrial water works."

In the cooling water system of this pump, water scale, such as calcium carbonate, settles on depending on the water quality, which may reduce the cooling water flow rate.

In addition, chlorine ions corrode the inner walls, which may cause leakage of cooling water.

Furthermore, when pure water is used, metal is separated therefrom, which may cause leakage of cooling water.

Note that in advance that in such a case, the repair cost may be borne by you.

Table 5 [Reference] The standard quality of water supply in the Japanese industrial water works

Turbidity	pH	Alkalinity	Hardness	Total residue on evaporation	Chloride ion	Iron	Manganese
20mg / L or less	6.5~8.0	75mg/L or less	120mg/L or less	250mg/L or less	80mg/L or less	0.3mg/L or less	0.2mg/L or less

Established by: Japan Industrial Water Association (Industrial water quality standard committee)

● **Do not install electrical equipment or wiring on the floor below or near this pump.**

This is designed so that no water leak occurs under the specified conditions and checked through a water leak test. However, in the event of abnormal conditions outside the specifications (e.g. an abnormal increase in water pressure), a water leak may occur. In that case, water will continue to leak unless the supply from the equipment is stopped. Do not install electrical equipment or wiring on the floor below or near this pump.

It is also recommended to place water leak sensors on the floor below and near this pump so that the power is shut off if a leak sensor is activated.

● **Install a flowmeter (e.g. flow sight) at the cooling water source.**

Install a flow meter (e.g. flow sight), which allows you to visually recognize the flow, at the cooling water supply source, such as a device, to check whether or not cooling water flows.

● **When using multiple units of this type, connect the cooling water pipes in parallel.**

When using multiple units of this type, connect the cooling water pipes in parallel. A series connection is insufficient in cooling capacity, which may cause a failure.

● **Water with a lot of impurities is filtered using a filter or by other means.**

When using water with a large amount of impurities, such as scale and iron, filter them with a filter installed in the prior stage before use.

● **Secure the required flow rate.**

If operation is continued with the cooling water flow rate below the specified amount, this pump may break down. Secure at least the specified flow rate. In addition, if the supply source and drain port are far apart from each other or if there is a height difference in the piping (lifting drainage to a position higher than this pump), a sufficient flow rate may not be secured. In that case, secure the flow rate by changing the piping layout, making the piping thicker, or increasing the supply pressure within the specified range.

● **Use the piping with an appropriate resistant water pressure and heatproof temperature.**

For the cooling water system, use joints and pipes with a resistant water pressure of 0.9MPa or more and a heatproof temperature of 70°C or more.

● **Do not use metal pipes other than SUS pipes in the cooling water system (including the equipment side)**

Do not use metal pipes other than SUS pipes in the cooling water system including in the equipment side. For example, when using metal pipes containing copper or zinc, ions may dissolve in water. The dissolved ions may precipitate and adhere to the inner wall of pipes, reducing the flow rate of the cooling water.

The cooling water piping used in this pump uses SUS pipes and PTFE tubes. Note in advance that repairs are charged for trouble caused by a blockage in a pipe due to precipitation or accumulation of impurities (scale, microorganisms, metal powder or metal ions) and deterioration of cooling efficiency.

■ **Specifications of connection**

Connection port: G1/2 female

■ **Applicable piping**

Joints and pipes with a resistant water pressure of 0.9MPa or more

Heatproof temperature: 70°C or more

Table 6: Piping specifications

Cooling water	Supply pressure (MPa)	0.1 ~ 0.3
	Differential pressure between inlet and outlet (MPa)	0.1 or more
	Flow rate (L/min)	3.0 or more
	Feed water temperature (°C)	5 ~ 30 (No condensation)

MEMO

During operation, cooling water cools down oil circulating in the pump using a heat exchanger. When the pump stops, oil stops circulating at the same time and the main unit of the pump and the oil tank are naturally-cooled. This cooling takes time.

3.6.4 Gas ballast gas

This unit comes equipped with the gas ballast function as standard. If the target gas contains a condensable gas and moisture, use the gas ballast gas to prevent liquid from accumulating inside the main unit. When air or nitrogen is introduced from the gas ballast valve immediately before the compression process of the pump, the condensable gas is discharged together through the exhaust valve without being liquefied.

For the standard model, the manual gas ballast valve is closed at the factory shipment. If necessary, loosen and open the manual gas ballast valve located inside using a slotted screwdriver in reference to "Figure 12: Manual gas ballast valve position."

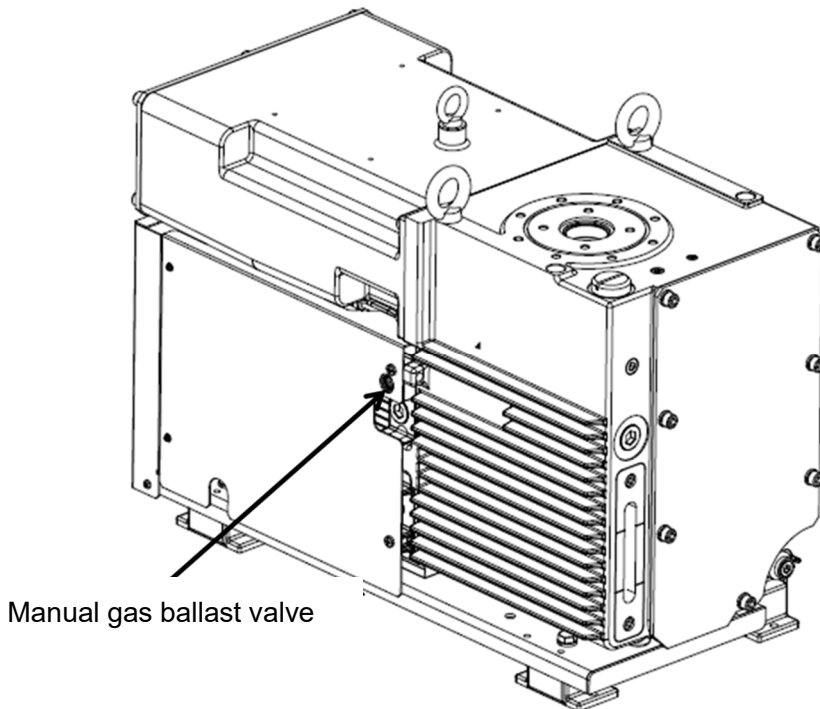

Figure 12: Manual gas ballast valve

* For the gas ballast function, refer to "4.3.4 Gas ballast function" on page 47.

3.6.5 Pump's ultimate pressure and operating noise

The pump's ultimate pressure and operating noise depend on the environment and power supply frequency used at your site.

During no-load pump operation in your environment, if the ultimate pressure does not drop below 15Pa on the pressure gauge directly over the pump or drops below 15 Pa but there is a high-pitched loud crackling noise called a punch noise, make an adjustment using the slow leak valve inside the panel.

●Conditions and measures

- During no-load pump operation, if the ultimate pressure does not drop below 15Pa on the pressure gauge directly over the pump.
Slowly tighten the valve while reading the pressure gauge.
The pressure slowly drops as it is tightened. However, if the valve is fully tightened, a punch noise occurs and the pump's operating noise becomes louder.
- In the case where the ultimate pressure is 15 Pa or less on the pressure gauge directly over the pump and the punch noise is loud during no-load pump operation
The punch noise is reduced by adjusting to approx. 15Pa while reading the pressure gauge.

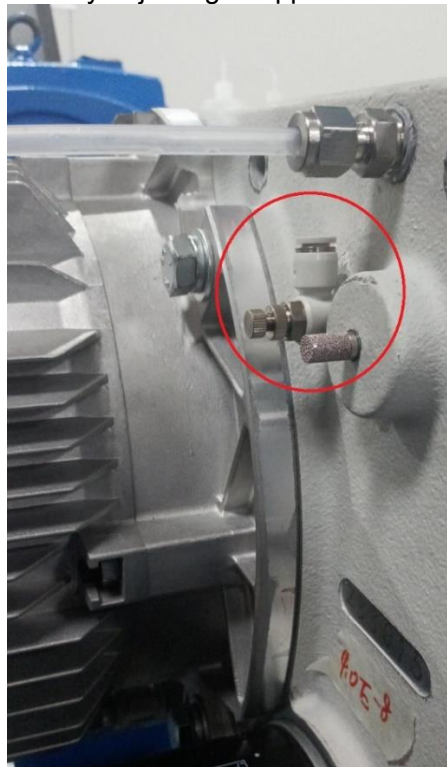

Figure 13: Slow leak valve position

MEMO

This pump is called a rotary-vane oil vacuum pump that supplies a large amount of oil into the cylinder to maintain the ultimate pressure.

This oil is sent to the discharge port by the rotation of the rotor and discharged to the outside of the pump. Oil that has not been successfully discharged is sent into a narrow space surrounded by cylinders and rotors, causing a collision. The high-pitched crackling noise that occurs when the ultimate pressure is reached is a punch noise, which is the collision noise of this oil.

The punch noise is more likely to occur with a large amount of oil sent to the narrow space surrounded by cylinders and rotors when less gas is exhausted and a larger amount of oil is sent to the inside of the cylinders. Therefore, the condition where the punch noise is most likely to occur is during operation at the ultimate pressure.

3.6.6 Purge gas

This pump has a purge gas port.

By introducing purge gas, most of air built up in the oil tank can be expelled. Remove the seal plug and introduce nitrogen or compressed air (CDA with a dew point of -60°C) as a purge gas.

NOTES



When introducing compressed air, set the supply pressure to 0.03MPaG or less.

When introducing nitrogen or compressed air (CDA with a dew point of -60°C), set the supply pressure to 0.03MPaG or less.

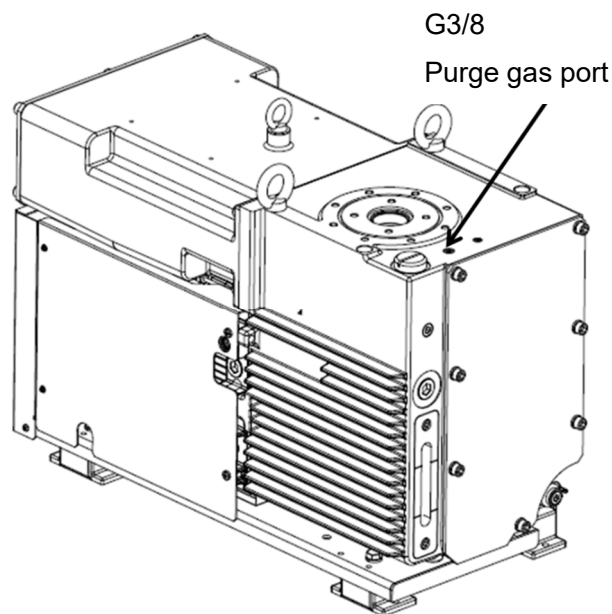





































Figure 14: Purge gas port position

▶ 3.7 Electric Wiring

3.7.1 Electric wiring

 DANGER  	<p><u>Electric wiring must be carried out by qualified personnel.</u></p> <p>Electric wiring must be carried out by qualified personnel.</p>
 DANGER  	<p><u>Wiring should be installed after disconnecting the open-circuit device.</u></p> <p>Before installing wiring, turn off the open-circuit device. Never leave the voltage applied during the work.</p>
 WARNING  	<p><u>Be sure to establish a ground for the ground terminal.</u></p> <p>For incomplete grounding, there is the risk of electric shock. Install grounding wires so that the wire lengths become as short as possible.</p>
 WARNING 	<p><u>Use cables certified by the national safety standards.</u></p> <p>Use cables certified by the national safety standards in the country of destination (e.g. products certified by UL, TUV).</p>
 WARNING  	<p><u>Do not use other than at the rated voltage.</u></p> <p>Do not use other than at the rated voltage. Otherwise the ground-fault interrupter or motor breaker does not work properly, causing burnout or fire.</p>
 WARNING 	<p><u>Comply with Rules and Laws and Regulations.</u></p> <p>Install and operate this pump in compliance with the safety codes and laws (e.g. fire protection laws and electric codes) in the country and region where you use this pump.</p>
 WARNING 	<p><u>Fix or cover the cables.</u></p> <p>Fix the cables so that they do not come into direct contact with this pump, or prepare covers (cable racks).</p>
 WARNING 	<p><u>Install the ground-fault interrupter in a readily accessible position and indicate that it is exclusively for this pump.</u></p> <p>In the event of a short circuit, it protects the equipment and wiring and protects against overload. In addition, it protects against an electric shock and a ground fault that can lead to fire due to electric leakage. If no ground-fault interrupter is installed or if it is installed but does not match the motor capacity, it may cause burn-damage to equipment, fire, or an electric shock.</p> <p>The open-circuit device of this pump is the ground-fault interrupter that is installed on the primary side by the customer. Install in a readily accessible position and indicate that it is an open-circuit device dedicated to this pump.</p>

 WARNING 	<p><u>Be sure to install an overload protector.</u></p> <p>Be sure to install an overload protector suitable for the capacity. If no overload protector is installed or it does not match the capacity, it causes damage to the motor or fire.</p>
 WARNING 	<p><u>In the wiring work, provide safety circuits.</u></p> <p>In the wiring work, be sure to provide safety circuits, such as molded-case circuit-breakers, electromagnetic contactors, and thermal overcurrent contactors.</p>
 WARNING 	<p><u>Use appropriate electromagnetic switches.</u></p> <p>The rated current value of the motor depends on the motor manufacturer. Use electromagnetic switches that work at the rated current of the motor for use.</p>
 WARNING 	<p><u>Make the thermal settings appropriately.</u></p> <p>Set the thermal setting to the rated current value of the motor that is suitable for the voltage and frequency of the power supply in use.</p>
 WARNING 	<p><u>Be sure to close the lid of the motor terminal box.</u></p> <p>After the completion of wiring to the motor, be sure to close the lid of the terminal box. Never open the lid during operation. There is the risk of electric shock.</p>
 WARNING 	<p><u>Check whether or not all screws inside the motor terminal box are tightened.</u></p> <p>Check that all screws inside the motor terminal box are tightened. If the tightness is insufficient, it may cause fire.</p>
 CAUTION 	<p><u>Install wiring for direct-connect starting.</u></p> <p>Install wiring for direct-connect starting. A star delta connection makes it difficult to start in some cases.</p>
<div style="background-color: #0056b3; color: white; padding: 5px; text-align: center;">NOTES</div> 	<p><u>When using an automatic vacuum breaking valve, connect it so that it works with the motor.</u></p> <p>When using an automatic vacuum breaking valve (a time-lag electromagnetic leak valve that opens 3 to 5 seconds to introduce air into the pump after the motor for driving the pump stops), connect it so that it works with the motor.</p>

- Use electrical wires certified by the national safety standards in the country of destination (e.g. products certified by UL, TUV).
- Confirm the specifications of the power supply of this unit. This unit does not have a mechanism to shut off the power. Be sure to install an MCCB (molded-case circuit-breaker) on the primary side. Prepare a power supply with the capacity to the power specifications of this unit in reference to "Table 7: List of wiring and ratings of recommended ground-fault interrupters" on page 37.
- When selecting wires, refer to the current at the maximum load for the model for use and check that the current is within the allowable range of the wire specifications. Also check that the wire size can

pass through the wire outlet.

- This unit uses 200-V and 400-V class shared motors. The unit can be operated without changing the 200-V and 400-V class motors by changing the wiring connections inside the motor terminal box.
- The ground terminal on the motor side is the screw indicated by the ground mark  in the terminal box. The power cord size connected to the ground must be at least the same as that of the power cord for the power supply to the motor. Set the ground resistance depending on the working voltage of the power supply: 200 V to 240 V: 100 Ω or less, 380 V to 460 V: 10 Ω or less.
- Decide the electric wire size in consideration of a voltage drop of the electric wire. Under normal conditions, use electric wires with a voltage drop within 2% of the motor rated voltage [Calculating formula of voltage drop: $\sqrt{3} \times \text{Wire Resistance } (\Omega/\text{km}) \times \text{Wiring Distance (m)} \times \text{Rated Current of Motor (A)} \times 10^{-3}$]
- Take measures such as lockout and tag out to prevent the power switch from being accidentally turned on during work.
- Set the voltage within the range of the rated voltage of $\pm 5\%$ (Variation: up to $\pm 10\%$).

Table 7: List of wiring and ratings of recommended ground-fault interrupters

Motor capacity	connection	Power-supply voltage	Power-supply frequency	Rated current	Molded-case circuit-breaker	Maximum power length	Recommended wire size	Connectable electrical wire Size	Recommended wire size	Connectable electrical wire Size	Recommended wire size	Connectable electrical wire Size
kW		V	Hz	A	A		For Japan		For USA		For Europe · China	
7.5	Δ-connection (Delta)	200	50	29.0	40	Setting < 30m	8mm ²	8mm ² -14mm ²	AWG8	AWG8-AWG6	9mm ²	9mm ² -14mm ²
		220	50	28.8								
		240	50	32.6								
		200	60	27.5								
		220	60	25.4								
		230	60	24.8								
		240	60	24.7								
	Y-connection (Star)	380	50	16.5	Setting < 80m							
		400	50	17.2								
		415	50	18.5								
		380	60	14.7								
		400	60	14.3								
		440	60	14.4								
		460	60	14.8								

Terminal symbol	Terminal screw	Tightening torque	Crimping terminal model number
		N · m	
U1 V1 W1	M5 nut Two-sided width : 8mm	2.0-25	R8-5
	M6 cross head screw	4.0-5.0	R8-6

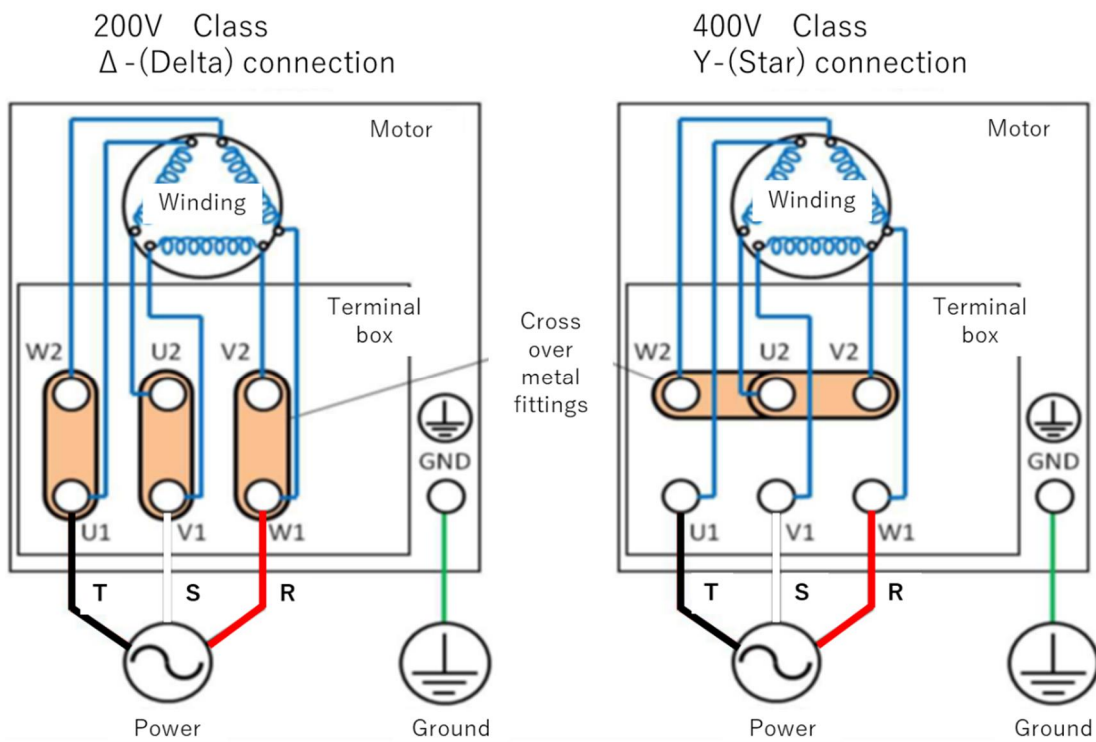
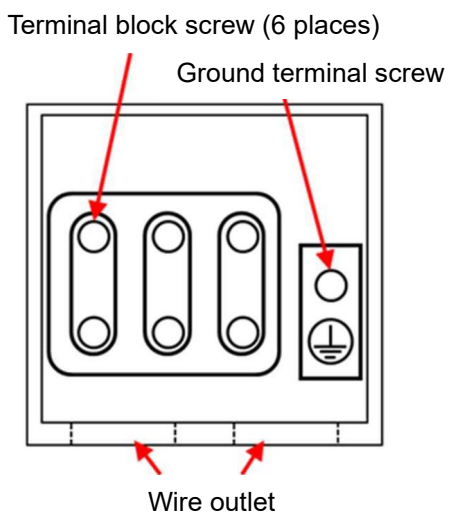

Figure 15: Connection wiring diagram in terminal box



Name	Terminal screw / Hole size	Tightening torque
Ground terminal screw	M6 cross head screw	4.0-5.0N·m
Terminal block screw	M5 nut	2.0-2.5N·m
Wire outlet	φ25	—

Figure 16: Major dimensions of terminal box

3.7.2 Wire connection of 24 VDC power connections

A thermostat is provided as standard on this unit to protect the pump when the pump overheats abnormally and exceeds the set temperature (80°C). Note that wiring needs to be installed to the 24-VDC power supply connection so that the power supply is shut off when the thermostat is activated. Be sure to make the above wiring connections to protect the pump so that it can be stopped safely. This thermostat is a bimetal type which opens the contact with an increase in temperature to cut off continuity. Once activated, it does not recover automatically.

Make sure that the pump temperature is low enough and that the power to the pump is turned off, and then remove the panel and press down the protrusion at the center of the thermostat.

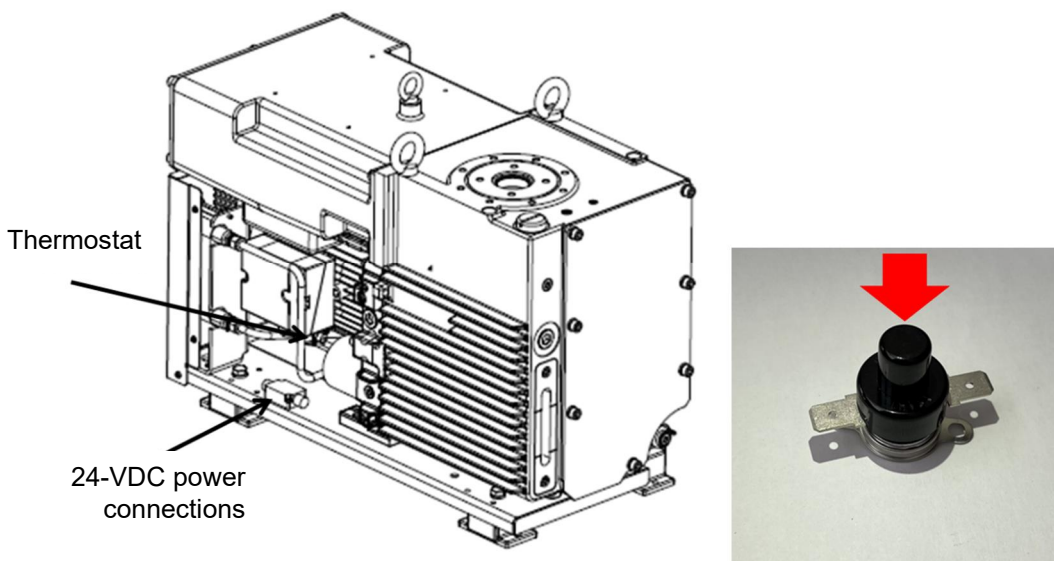
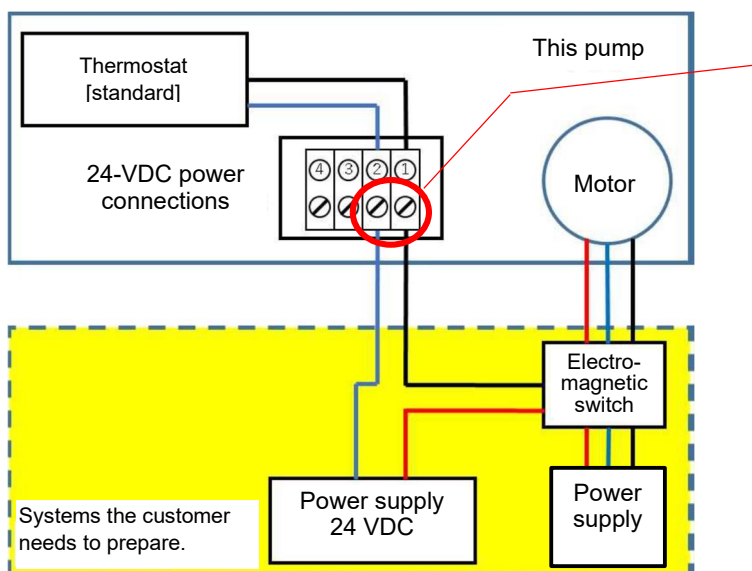

Figure 17: Positions of 24-VDC power connections







































24-VDC power connections Terminal block screw	M3 cross head screw
Connector-compatible wire	φ 3.5~7.3
Tightening torque	1.2N·m









Figure 18: Wire connection diagram and major dimensions of 24VDC power connections







4. Operation

▶ 4.1 Precautions on Operation

 DANGER 	<p><u>Do not use any gas other than inactivity gas</u></p> <p>The pumping of toxic gas, flammable gas, combustible gas, corrosive gas, explosive gas and particle gas, may damage this pump and hazardous. Furthermore, the chemical reaction of remaining gases and/or generated particle and gases may cause the explosion, not only during operation but also after stop operation.</p>
 DANGER 	<p><u>Do not use toxic gases into this pump</u></p> <p>When toxic gases were pumped, not only this pump but also the oil becomes toxic. Please be careful during maintenance.</p>
 WARNING 	<p><u>Do not use in areas where a hazardous atmosphere may form or occur</u></p> <p>Do not use in areas where a hazardous atmosphere may be formed or occur due to explosive gas. Otherwise, injury or fire may occur.</p>
 WARNING 	<p><u>Never place flammables within 1 m around the motor and vacuum pump.</u></p> <p>Never place flammables within 1 m around the motor and vacuum pump. There is a risk of fire.</p>
 WARNING 	<p><u>Do not block the exhaust port</u></p> <p>Do not operate this pump with any equipment installed on the exhaust port side that prevents gas from passing in such a way as to block the exhaust port. Pressure in this pump may increase, which causes a rupture of or oil leakage from the casing or level gauge, or overloads the electric motor. This pump is not explosion proof structure. The guaranteed pressure value of this pump is 0.03MPaG (0.3kg / cm²G) (gauge pressure).</p>
 WARNING 	<p><u>Leave 0.7m or more of space to the ventilation port of the motor.</u></p> <p>If there are walls or obstacles within 0.7m from the ventilation port of the motor, there is a risk of burn injury and fire due to abnormal overheating.</p>
 WARNING  	<p><u>During operation or immediately after a shutdown, do not touch the pump body or piping.</u></p> <p>During operation or immediately after a shutdown, do not touch the bump body or piping as they are at a very high temperature. If a human body touches the machine, it may get burned.</p>
 WARNING 	<p><u>If it does not work or there is an abnormality, immediately turn off the open-circuit device.</u></p> <p>If it does not work or there is an abnormality, immediately turn off the open-circuit device to prevent accidents. Contact your nearest service center for inspection/repair.</p>

 WARNING 	<p><u>Close the gas ballast valve before starting operation.</u></p> <p>Be sure to close the gas ballast valve before starting operation. In high pressure regions, oil may blow out from the gas ballast valve.</p>
 WARNING 	<p><u>Do not touch any place other than the valve during gas ballast operation.</u></p> <p>During operation of this pump, the machine body is at a high temperature. Do not touch any place other than the valve during gas ballast operation.</p>
 WARNING 	<p><u>Do not touch rotating parts, such as the motor, main spindle, and spindle joints, during operation.</u></p> <p>Do not touch rotating parts, such as the motor, main spindle, and spindle joints, during operation of this unit. You may get injured.</p>
 WARNING 	<p><u>Do not put your fingers or objects in the opening of the motor.</u></p> <p>Do not put your fingers or objects in the opening of the motor. There is a risk of electric shock, injury, fire, or other problems.</p>
 WARNING 	<p><u>Do not remove the exterior panel.</u></p> <p>Never remove the exterior panel. There are electrical components, wires, and rotating parts, such as a motor, main spindle, and spindle coupling inside the panel. You may get an electric shock or injured if you touch them.</p>
 CAUTION 	<p><u>Confirm that the valve is open</u></p> <p>If the valve is installed on a pipe after the exhaust port, make sure that the valve is open.</p>
 CAUTION 	<p><u>Use the unit with a specified amount of oil.</u></p> <p>Be sure to use the unit with a specified amount of oil. If it exceeds the upper limit, oil may blow out from the exhaust port when entering the atmosphere. In addition, if the oil level becomes lower than the lower limit during the operation, the bearings, spindle seals, etc. are damaged, which causes a leakage, abnormal noise, overloaded motor, or shutdown, causing a malfunction. When it is necessary to add oil, use the same oil as that being used.</p> <p>* For the amount of oil, refer to "8.1 Performance Specifications" on page 69.</p>
 CAUTION  	<p><u>Control the oil level for continuous operation at high suction pressures.</u></p> <p>Continuous operation for 1 hour or more at a high pressure of 1,000 Pa or more increases the amount of oil discharged as oil smoke, which results in a shortage of oil, causing failures such as rapid wear or seizing up of the components. Add oil frequently to control the oil level. Note that the maintenance cycle may be shorter.</p>
 CAUTION  	<p><u>For continuous operation at high suction pressures, change oil frequently.</u></p> <p>Continuous operation at high suction pressures causes an extremely high oil temperature. Consequently, the oil rapidly deteriorates, resulting in poor ultimate pressure and pumping speed, rapid wear of the parts, or failures such as seizing up. Change oil frequently.</p>

 <p>CAUTION</p> 	<p><u>When exhausting a large amount of water etc., change oil frequently.</u></p> <p>When exhausting a gas containing a large amount of moisture etc., change oil frequently. When operating with a large amount of water mixed in oil, the ultimate pressure first increases and then the oil lubricity deteriorates. This may lead to failures such as oil leaks through oil seals, internal corrosion, breakage of exhaust plate, and seizure inside the pump.</p>																
 <p>CAUTION</p> 	<p><u>Do not clog the oil filter.</u></p> <p>If the amount of oil circulation is reduced due to a clogged oil filter, it may cause failures such as rapid wear or seizing up of the parts. This is highly likely to occur especially in high pressure regions. Take care.</p> <p>* For replacement of the oil filter, refer to "6.2.8 Replacement of oil filter" on page 62.</p>																
<p>NOTES</p> 	<p><u>Be sure to supply the specified amount of cooling water.</u></p> <p>If the amount of cooling water is reduced, it may cause failures such as rapid wear or seizing up of the components of this pump. Take care especially in high pressure regions as this is highly likely to occur there. It is recommended to install a flowmeter in the cooling water system and provide an interlock that stops this unit when the amount of water becomes equal to or lower than the specified value.</p>																
<p>NOTES</p> 	<p><u>Use water with fewer impurities for cooling water</u></p> <p>It is recommended to use water with fewer impurities (e.g. industrial water; refer to the table below) for cooling water of this pump. In the cooling water system of this pump, water scale, such as calcium carbonate, settles on depending on the water quality, which may reduce the cooling water flow rate. In addition, chlorine ions corrode the inner walls, which may cause leakage of cooling water. Furthermore, when pure water is used, metal is separated therefrom, which may cause leakage of cooling water. Note that in advance that in such a case, the repair cost may be borne by you.</p> <p>[Reference] The standard quality of water supply in the Japanese industrial water works</p> <table border="1" data-bbox="443 1328 1461 1478"> <thead> <tr> <th>Turbidity</th> <th>pH</th> <th>Alkalinity</th> <th>Hardness</th> <th>Total residue on evaporation</th> <th>Chloride ion</th> <th>Iron</th> <th>Manganese</th> </tr> </thead> <tbody> <tr> <td>20mg / L or less</td> <td>6.5~8.0</td> <td>75mg/L or less</td> <td>120mg/L or less</td> <td>250mg / L or less</td> <td>80mg/L or less</td> <td>0.3mg/L or less</td> <td>0.2mg/L or less</td> </tr> </tbody> </table> <p>Established by: Japan Industrial Water Association (Industrial water quality standard committee)</p>	Turbidity	pH	Alkalinity	Hardness	Total residue on evaporation	Chloride ion	Iron	Manganese	20mg / L or less	6.5~8.0	75mg/L or less	120mg/L or less	250mg / L or less	80mg/L or less	0.3mg/L or less	0.2mg/L or less
Turbidity	pH	Alkalinity	Hardness	Total residue on evaporation	Chloride ion	Iron	Manganese										
20mg / L or less	6.5~8.0	75mg/L or less	120mg/L or less	250mg / L or less	80mg/L or less	0.3mg/L or less	0.2mg/L or less										
<p>NOTES</p> 	<p><u>Pay attention to a decrease in amount of cooling water</u></p> <p>If the amount of cooling water is reduced, it may cause failures such as rapid wear or seizing up of the components of the pump. Take care that this is highly likely to occur especially when inlet pressure is high,</p>																
<p>NOTES</p> 	<p><u>Use with the exterior panel attached.</u></p> <p>Operating with the exterior panel removed may lower the performance. Be sure to use with the exterior panel attached. Pumping performance may not be fully provided under the condition immediately after the startup and with the panel removed.</p>																
<p>NOTES</p> 	<p><u>Warm up for approx. 30 minutes (recommended) after startup</u></p> <p>In order to make full use of the pump performance of this pump, it is recommended to warm up for approx. 30 minutes after startup.</p>																

<p>NOTES</p> 	<p><u>Take care not to allow foreign matter to mix.</u></p> <p>If the pump sucks solids, such as dust and fine powder, or water, not only the ultimate pressure gets worse but also it may cause a failure. The inside of the pump is designed to rotate with a slight clearance and, if foreign matter enters the pump, it may become unable to rotate.</p>
<p>NOTES</p> 	<p><u>Suction of chemicals such as acid</u></p> <p>If chemicals such as acid is drawn in, it may become unable to operate. If chemicals such as acid is drawn in, it may rust and become inoperable during the period of overnight stop. Therefore, change oil immediately after drawing in. This unit is not covered by the warranty if used for drawing in chemicals.</p>
<p>NOTES</p> 	<p><u>Do not draw in chemicals such as solvents.</u></p> <p>If chemicals such as solvents are drawn in, it may become unable to operate. If a solvent or another chemical that deteriorates the oil lubricity is drawn in, change the oil as it may cause galling or other problems. This unit is not covered by the warranty if used for drawing in solvents or the like.</p>
<p>NOTES</p> 	<p><u>Install an oil mist separator on the exhaust port side.</u></p> <p>Operating in high pressure regions generates oil smoke (oil mist) from the exhaust side. Install the duct piping through the separator.</p> <p>* This unit comes equipped with an oil mist separator as standard.</p>
<p>NOTES</p> 	<p><u>When using an automatic vacuum breaking valve, connect it so that it works with the motor.</u></p> <p>When using an automatic vacuum breaking valve (a time-lag electromagnetic leak valve that opens 3 to 5 seconds to introduce air into the pump after the motor for driving the pump stops), connect it so that it works with the motor.</p>
<p>NOTES</p> 	<p><u>Operate this unit after its temperature reaches the operational ambient temperature.</u></p> <p>If this pump was stored outside the range of the operational ambient temperature, operate it after its temperature reaches the operational ambient temperature. Otherwise it may cause a malfunction.</p>

▶ 4.2 Preparation for Operation

4.2.1 Pre-operation check

Before operating this pump, reconfirm the following.

1. Make sure that the cooling water piping and electric wiring connection are completed.
2. Check that the exhaust port is not blocked by a protective cap or storage flange.
3. Check whether the specified amount of oil is contained. (Refer to "**Figure 10: Specified oil level**" on page 25.)
4. Open the cooling water valve and check that there is no cooling water leakage.
5. Check whether the gas ballast valve is closed.
In high pressure regions, oil may blow out from the gas ballast valve.
6. Supply power to the primary side.
Make the following checks with the vacuum valve closed and the leak valve open.
The vacuum gauge is prevented from being damaged or jumped out in the reverse rotation.
7. Check whether the direction of rotation of the motor is correct. (Refer to "**Figure 19: Direction of rotation of motor.**")

● Confirmation of motors rotary direction

Make the checks with the vacuum valve closed and the leak valve open.

The vacuum gauge is prevented from being damaged or jumped out in the reverse rotation.

1. Operate this pump for approx. 1 to 2 seconds and stop it.
2. During the above operation, confirm the direction of rotation of the motor viewed from the ventilation port of the motor. The direction of rotation is that indicated by the arrow shown in the photo.

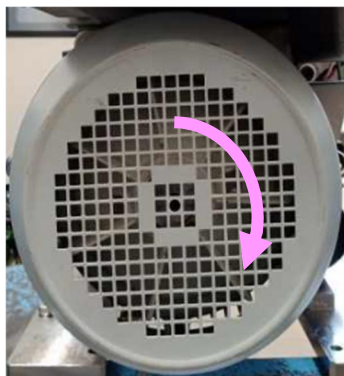

Figure 19: Direction of rotation of motor

If the motor rotates in the correct direction, close the leak valve. The pressure decreases.

If the motor rotates in the opposite direction, the phases on the power supply side are exchanged. Therefore, exchange two of the three wires shown in "**Figure 15: Connection wiring diagram in terminal box**" on page 38.

▶ 4.3 How to Startup/Stop

4.3.1 Startup

To start this pump, follow the procedure below.

1. Close the vacuum valve and leak valve.
2. Turn on the power to the motor.
3. Check whether the pressure gauge between the vacuum valve and the pump indicates a pressure drop to around the ultimate pressure.
4. If the pressure does not drop, refer to "7. Troubleshooting" on page 65.
5. Open the vacuum valve.

In cold climates, the oil viscosity increases, which may make it difficult to start with the specified power. In such a case, fully open the leak valve and operate for several minutes with the inlet port exposed to atmospheric pressure. Then the oil temperature increases and the current returns to the specified value. If the current value does not drop with time, stop immediately. Also take care if the current value fluctuates irregularly.

If irregular abnormal noises and vibrations occur, stop the operation immediately.

* When using the gas ballast gas, refer to "4.3.4 Gas ballast function" on page 46.

4.3.2 Stop

The inlet port of this pump has a function to seal the inlet port when this pump stops. This keeps the inside of the vacuum vessel in a vacuum even after the unit stops.

To stop this pump, follow the procedure below.

1. Close the vacuum valve.
2. Open the leak valve.
3. Stop the pump and return the pressure inside the pump to atmospheric pressure.

When stopping the operation, be sure to close the vacuum valve to keep the unit side in a vacuum, open the leak valve, and then stop the pump. Failure to follow this operation may cause the pump cylinder filled up with oil in a few minutes, making it difficult to restart or causing damage to the pump. In addition, oil flows back to the vacuum chamber side in some cases.

If the vacuum valve is not closed, a vacuum leakage may occur from the displacement side through the inside of the pump.

MEMO

- When using the vacuum valve in combination with a pneumatic valve or electromagnetic (electric) valve or using the leak valve in combination with an automatic vacuum breaking valve, it is helpful with no worries even when the operation stops in an emergency.
- During operation, cooling water cools down oil circulating in the pump using a heat exchanger. When the pump stops, oil stops circulating at the same time and the main unit of the pump and the oil tank are naturally-cooled. This cooling takes time.

4.3.3 Drain of this pump

Perform drain work when there is a risk of freezing or when this pump is not used for a long period of time.

NOTES	<u>Drain water in this pump.</u>
	Drain water in this pump. Accumulated water may cause a failure, such as rusting inside this pump and damage to the parts due to freezing.



■ Drain of this pump

When draining the cooling water from the pump, follow the procedure below:

1. Introduce compressed air from "Cooling Water Inlet" of the pump cooling water pipe.
Set the supply pressure of compressed air to 0.3MPaG or less.
2. When compressed air is discharged from "Cooling Water Outlet," this drain work is completed.

4.3.4 Gas ballast function

This pump comes equipped with the gas ballast function as standard. If the target gas contains a condensable gas and moisture, use the gas ballast gas to prevent liquid from accumulating inside the main machine. When air or nitrogen is introduced from the gas ballast valve immediately before the compression process of the pump, the condensable gas is discharged together through the exhaust valve without being liquefied.

NOTES	<u>Wear protective gloves.</u>
	During operation of this pump, the main pump is at a high temperature. When working with this pump, wear protective gloves.
NOTES	<u>If no condensable gas is sucked, close the gas ballast valve.</u>
	If no condensable gas is sucked, close the gas ballast valve.
NOTES	<u>Do not introduce compressed air into the gas ballast port.</u>
	Do not introduce nitrogen or compressed air (CDA with a dew point of -60°C) into the gas ballast port under positive pressure conditions. If nitrogen or CDA needs to be introduced, adjust to atmospheric pressure before introducing it.

MEMO

- The condensable gas is sucked and then liquefied in the compression process of the pump, mixed with the oil, and starts to circulate in the pump with oil. This is the same as using oil with high vapor pressure, increasing the ultimate pressure of the pump. In addition, the oil lubricity decreases, shortening the life of the shaft seal.
- When using the gas ballast valve, it is recommended to warm up the unit for approx. 20 minutes before sucking condensable gas. The higher the pump temperature, the greater the "gas ballast effect" will be. The "gas ballast effect" at a low temperature is less than the specified processing capacity.

■ How to operating of gas ballast

1. Close the vacuum valve, leak valve, and gas ballast valve, and start operation.
2. After the pressure drops, introduce air or nitrogen from the gas ballast valve.
3. Continue operation for approx. 20 minutes to sufficiently increase the temperature of the machine.

If a lot of moisture enters the pump at a time and cannot be processed, the moisture is built up at the bottom of the oil tank. In that case, open the oil drain port a little to drain the water.

There is a limit to the processing capacity of gas ballast gas for condensable gas. After discharging a large amount of condensable gas or discharging condensable gas without opening the gas ballast valve, the condensable gas remains in the oil. In this case, oil can be purified by following the procedure below.









■ How to purify oil

1. Close the vacuum valve and gas ballast valve, and start operation.
2. After the pressure drops, introduce air or nitrogen from the gas ballast valve and operate the unit at idle.
3. Close the gas ballast valve and check whether the specified ultimate pressure is provided. If it is provided, purification is completed.
If not, repeat Step 2.

MEMO

- The oil temperature increases and oil can be purified by the gas ballast effect. If purification does not proceed even after a long period of time, it is necessary to change the oil.

5. Removal







 DANGER 	<p><u>Do not suck toxic gases into this pump.</u></p> <p>If toxic gases are sucked into this pump, not only this pump but also the oil becomes toxic. Take care during maintenance.</p>
 DANGER 	<p><u>Before installation or removal work, disconnect this pump from all energy sources.</u></p> <p>Before installation or removal work, disconnect this pump from all energy sources (such as electricity, compressed air, and cooling water). * If you are using compressed air, nitrogen gas, or other gases, remove it.</p>
 WARNING  	<p><u>Wait for the temperature of this pump to decrease.</u></p> <p>Immediately after operation is stopped, this pump is at a high temperature. Wait for a while until the temperature of this pump decreases and then remove and check the parts. Otherwise, you may get burned.</p>
NOTES 	<p><u>If a special gas is exhausted, replace it sufficiently with nitrogen gas.</u></p> <p>If a special gas is exhausted, replace the gas inside the pump sufficiently with nitrogen gas before removal.</p>

To remove this pump, follow the procedure below:

1. Stop this unit and release the inside of the pump to atmospheric pressure.
 * For details on how to stop this unit, refer to "4.3.2 Stop" on page 45.
2. Turn off the power and disconnect the wiring.
3. Drain the oil.
 * Refer to "6.2.1 Inspection and replacement of oil" on page 52.
4. Drain the cooling water inside this unit and remove the cooling water piping. (For water cooling type)
 * Refer to "4.3.3 Drain of this pump" on page 46.
5. Remove the inlet/exhaust piping and seal the inlet/exhaust port of this unit with a blind flange.
 * Remove the inlet port piping following the installation manual of the equipment.
 If the piping to the gas ballast valve or to the oil filler/drain port is installed, remove it as well.

▶ 5.1 Removal of Piping







5.1.1 Cooling water piping

 WARNING  	<p><u>Wait for the temperature of this pump to decrease.</u></p> <p>Immediately after operation is stopped, this pump is at a high temperature. Wait for a while until the temperature of this pump decreases and then remove and check the parts. Otherwise, you may get burned.</p>
<p>NOTES</p> 	<p><u>Close the cooling water supply valve on the primary side and then the drain valve.</u></p> <p>Make sure that the temperature of this pump has dropped and then close the cooling water supply valve on the primary side. After that, close the drain valve. If this is done in reverse order (closing the drain valve and then the supply valve), residual pressure remains in the piping. When you remove the piping, the cooling water blows out vigorously. Therefore, close the valves in the correct order.</p>
<p>NOTES</p> 	<p><u>Make sure using a visually recognizable flow meter that the cooling water does not flow.</u></p> <p>Check that the cooling water does not flow using the visually recognizable flow meter (e.g. flow sight) at the cooling water supply source on the primary side.</p>
<p>NOTES</p> 	<p><u>Drain water in this pump.</u></p> <p>Drain water in this pump. Accumulated water may cause a failure, such as rusting inside this pump and damage to the parts due to freezing.</p> <p>* For drain work, refer to "4.3.3 Drain of this pump" on page 46.</p>

 MEMO



During operation, cooling water cools down oil circulating in the pump using a heat exchanger. When the pump stops, oil stops circulating at the same time and the main unit of the pump and the oil tank are naturally-cooled. This cooling takes time.

5.1.2 Inlet/exhaust port piping

 WARNING  	<p><u>After the temperature of this pump decreases, remove the piping for the inlet/exhaust port.</u></p> <p>The unit remains at a high temperature for a while after operation stops. Make sure that the temperature of the main unit has decreased and then remove the piping for the inlet/exhaust port.</p>
 CAUTION 	<p><u>After the temperature of this pump decreases, remove protective cover.</u></p> <p>The temperature of the inlet/exhaust piping is 70°C or more. Make sure that the temperature of this pump has decreased and then remove the protective cover.</p>
NOTES 	<p><u>Fully seal the inlet/exhaust port with a blind flange or cap, or by other means.</u></p> <p>After removing the inlet/exhaust piping, fully seal the inlet/exhaust port of this unit with a blind flange or cap, or by other means.</p>
NOTES 	<p><u>Remove according to the installation manual for the equipment on the primary side.</u></p> <p>Remove according to the installation manual for the equipment on the primary side.</p>

6. Maintenance and Inspection

Daily and regular inspection and maintenance work are required to maintain the original performance of this pump and ensure safe use.

	<p><u>Before inspection/relocation, turn off the open-circuit device and lock (LOTO).</u></p> <p>Before inspection/relocation, be sure to turn off the open-circuit device and lock (LOTO). Never leave the voltage applied during the work. - There is the risk of electric shock.</p>
	<p><u>Wear protective equipment</u></p> <p>During work such as inspection, wear protective equipment suitable for toxic substances for use.</p>
	<p><u>No one other than a service engineer is allowed to disassemble, repair, or modify.</u></p> <p>No one other than a service engineer must be allowed to disassemble, repair, or modify. You may get injured due to ignition or abnormal operation, or get an electric shock.</p>

▶ 6.1 Daily Inspection

Check the following items to prevent pump failures and extend this pump's life. For the visual inspection levels and utility-related items, it is recommended to check them on a daily basis to see the condition of the unit. Check more frequently during high-load operation (continuous operation at 1,000 Pa or more in a repeated cycle between atmospheric pressure and a vacuum).

Table 8: Daily inspection list













Item	Check item	Troubleshooting
Oil amount	Is the oil level between the level lines of the oil level gauge during operation?	Adjust the oil level so that it is between the level lines of the oil level gauge.
Oil color	Is oil discolored? Refer to "Figure 20: Oil color sample."	If discolored, change the oil.
Oil leak	Is there any oil leak around the pump?	Refer to "6.2.2 Oil leakage check" on page 54.
Oil temperature	Check the piping temperature on the thermostat side. Is it 75°C or less?	Refer to "6.2.8 Replacement of oil filter" on page 62.
Amount of cooling water	Is cooling water at the specified flow rate?	Check the cooling water feed valve, drain valve, water pressure, and piping, and make an adjustment so that the specified amount of cooling water flows.
Cooling water leakage	Is the floor wet?	Inspect the cooling water inlet, cooling water outlet, fittings, and piping.
Abnormal Noise/Vibration	Is there any abnormal noise or vibration?	Refer to "6.2.3 Inspection of abnormal noise and vibration" on page 54.
Oil mist separator	The internal pressure of the pump is a limit value of 0.03 MPaG. Does it exceed (0.3 kg/cm ² G)?	Refer to "6.2.4 Inspection and replacement of oil mist separator" on page 55.



▶ 6.2 Regular Inspection

The check items need to be changed depending on the use conditions of the pump, but the following points need to be checked regularly. It is effective in avoiding failures to extend the life of the pump.

6.2.1 Inspection and replacement of oil

The oil is not only contaminated by suction gas but also gradually deteriorated by a temperature rise during the pump operation. Check the degree of contamination and viscosity and change the oil regularly. It is also recommend to replace the oil filter regularly.

 DANGER 	<p><u>Do not suck toxic gases into this unit.</u></p> <p>If toxic gases are sucked into this unit, not only this unit but also the oil becomes toxic. Take care during maintenance.</p>
 DANGER 	<p><u>Wear protective equipment</u></p> <p>During work such as inspection, wear protective equipment suitable for toxic substances for use.</p>
 WARNING  	<p><u>Thoroughly read the SDS.</u></p> <p>Obtain the SDS and thoroughly read it in advance. If oil comes into contact with your skin or eyes, follow the SDS's first aid section.</p>
 CAUTION 	<p><u>The first oil change is to be done within 10 days.</u></p> <p>Depending on the application purpose, oil may deteriorate in a very short period of time. It is recommended that the first pump oil change be performed within 10 days and decide the oil change cycle after judging the degree of oil contamination. * For the oil change interval, refer to "Table 9: Guideline for oil change interval" on page 53.</p>
 CAUTION 	<p><u>For continuous operation at high suction pressures, change oil frequently.</u></p> <p>Continuous operation at high suction pressures causes an extremely high oil temperature. Consequently, the oil rapidly deteriorates, resulting in poor ultimate pressure and pumping speed, rapid wear of the parts, or failures such as seizing up. Change oil frequently. It is also effective to install an oil cooler to cool the oil inside the pump.</p>
 CAUTION 	<p><u>When exhausting a large amount of water etc., change oil frequently.</u></p> <p>When exhausting a gas containing a large amount of moisture etc. change oil frequently. When operating with a large amount of water mixed in oil, the ultimate pressure first increases and then the oil lubricity deteriorates. This may lead to failures such as oil leaks through oil seals, internal corrosion, breakage of exhaust plate, and seizure inside the pump.</p>

NOTES	<u>Use the specified oil.</u>
	The use of any oil other than the specified ones affects the performance and life of this unit, which is not covered by the warranty.
NOTES	<u>Suction of chemicals such as acid</u>
	If chemicals such as acid is drawn in, it may become unable to operate. If chemicals such as acid is drawn in, it may rust and become inoperable during the period of overnight stop. Therefore, change oil immediately after drawing in. This unit is not covered by the warranty if used for drawing in chemicals.
NOTES	<u>Do not draw in chemicals such as solvents.</u>
	If chemicals such as solvents are drawn in, it may become unable to operate. If a solvent or another chemical that deteriorates the oil lubricity is drawn in, change the oil as it may cause galling or other problems. This unit is not covered by the warranty if used for drawing in solvents or the like.

■ How to change oil

1. Stop the pump, open the oil drain port (drain valve), and drain oil from the oil tank.
2. After the completion of draining the oil, close the oil drain port (drain valve) once, operate the pump at idle for approx. 5 seconds, and also drain the oil coming out from the cylinder.
3. If necessary, replace the oil filter.
4. Close the oil drain port (drain valve) and add new oil from the oil filler port.
Add oil so that the oil level is set between the "MAX" and "MIN" level lines of the oil level gauge.
Refer to "**Figure 9: Oil filler port and oil level gauge positions**" and "**Figure 10: Specified oil level**" on page 25.

If the oil is extremely dirty, add new oil and operate for a few minutes to clean the inside of the pump. Also repeat this process several times depending on the degree of contamination of the oil.

After changing the oil with new one, operate the pump, wait for the pump to warm up, and then check the ultimate pressure.

MEMO

- If any substance of low boiling point (such as water and organic solvents) mixes with oil or any slime foreign substance (sludge) is accumulated at the bottom of the pump case, the oil needs to be changed not only once but several times to recover the ultimate pressure. If the desired ultimate pressure is not obtained even after changing the oil, an overhaul is necessary. Contact your nearest service location.

Table 9: Guideline for oil change interval

Application	Replacement interval
Research/Experimental vacuum equipment, small vacuum equipment	Within 6 months to 1 year
Production vacuum equipment, vacuum deposition	Within 3 to 6 months
Tube exhaust equipment, large-sized vapor deposition equipment	Within 3 months
Metallurgical vacuum equipment for heat treatment, melting, or other purposes	Within 1 month
High vacuum drying, vacuum impregnation, vacuum forming, vacuum packaging equipment	Within 1 month
Low vacuum drying, clay kneaders, food packaging machines	Within 1 week

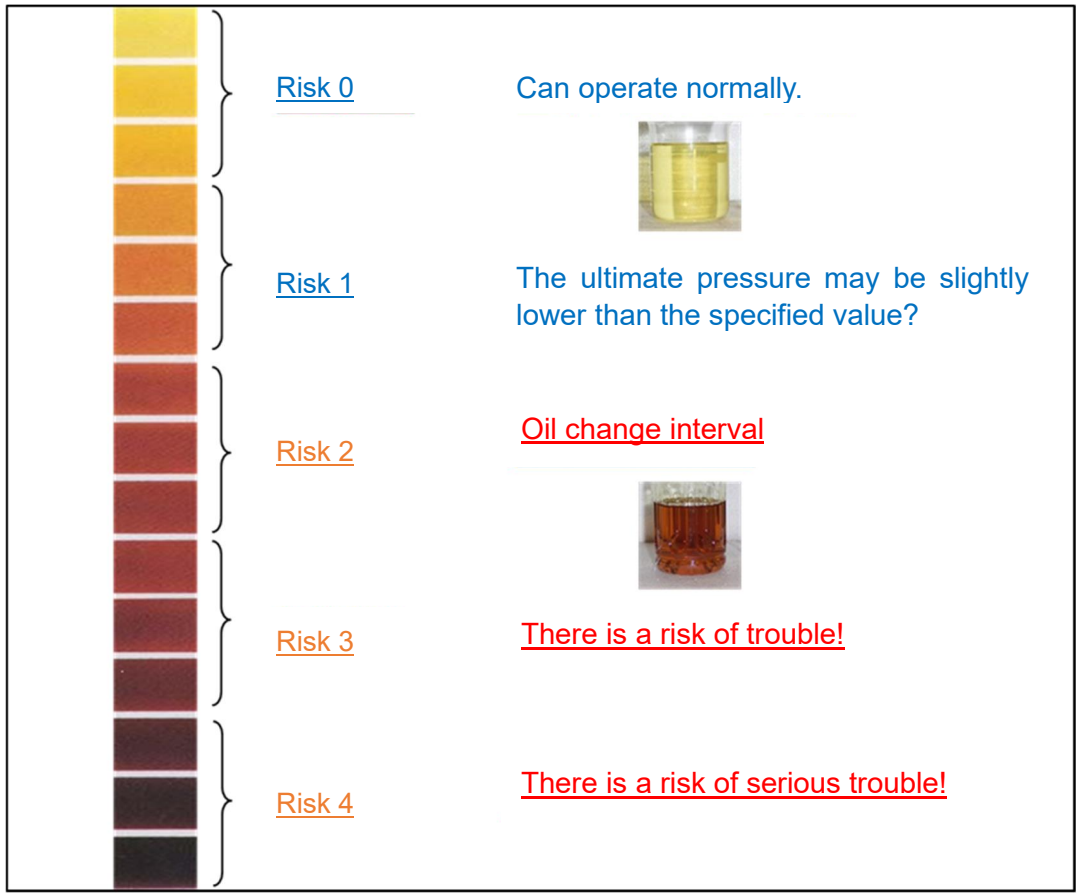

Figure 20: Oil color sample

6.2.2 Oil leakage check

In the event of oil leakage from the shaft-seal part or the pump body, it need to be repaired. The seals and O-rings used in this pump are described at the end of this manual. Contact your nearest service center.

6.2.3 Inspection of abnormal noise and vibration

If any abnormal noise or vibration occurs in the pump, check the following. If the trouble persists even after checking these items, contact your nearest service center.

Item	Description	Troubleshooting
Inspection of the areas around the pump	Additionally tighten the nuts and bolts that fix the pump.	Provide additional tightening.
	Additionally tighten the bolts that fix the panel?	Provide additional tightening.
	Additionally tighten the fixed parts of the piping connected to the inlet/exhaust ports?	Provide additional tightening.
	Is there any leakage from the piping or valves? If any, stop the leak.	Stop leakage.
Inspection of pump	Refer to "7. Troubleshooting" on page 64.	

6.2.4 Inspection and replacement of oil mist separator

This unit comes equipped with an oil mist separator as standard. The oil mist separator separates oil from the gas discharged from the pump.

Severe clogging of the separator can prevent exhaust gas from passing through the filter, increasing the pressure inside the pump and causing the pump and oil mist separator to burst.

■ How to inspect the oil mist separators

The limit value of the internal pressure of the pump is 0.03MPaG (0.3 kg/cm²G).

It is recommended to remove the seal plug from the pressure gauge mounting port and install a pressure gauge for daily inspection. In addition, it is recommended to install a pressure switch in parallel with the pressure gauge and provide an interlock that stops the pump when pressure becomes equal to or higher than the specified value (refer to "Figure 4: System connection diagram" on page 14).

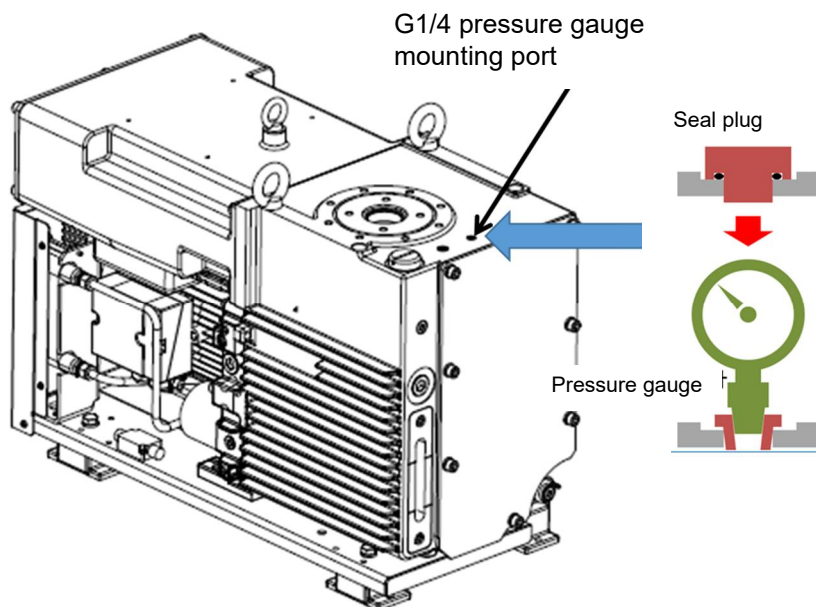

■ Replacement of oil mist separator

1. Stop the pump.
2. Remove the red-circled cover of the oil mist separators.



3. Remove the two inner bolts.



4. Remove the oil mist separator support. After the support is removed, the filter can be removed. Take care not to drop or make an impact. In addition, oil deposited on the oil mist separators streams down. Therefore, when removing oil mist separators, it is recommended to put an oil pan on the floor.



5. Take out the oil mist separators. Prepare new oil mist separators. O-rings (P35) to be attached to the oil mist separators are supplied when a new product is purchased.



6. Install the oil mist separators in the reverse order of removal.

6.2.5 Replacement of exhaust valve plate

Replace the exhaust valve plate every 8,000 hours. It may break early due to suction of foreign matter and water.

■ Replacement of Exhaust Valve Plate

1. Stop the pump.
2. Remove the maintenance cover on the side of the pump.



3. Take care in removing it as it is a heavy object. Remove the exhaust baffle. Remove the four bolts that fix the baffle. When removing, take care not to drop the bolts and spring washers. After removing the bolts, rotate and take out the baffle as shown on the right of the photo.



4. Remove the bolts that fix the Z-type oil fence, exhaust valve guide, and exhaust valve plate (indicated by the red arrow in the photo below). At this time, do not remove the exhaust valve plate until all bolts are removed. This prevents bolts and spring washers from dropping into the cylinder through the exhaust port. If any parts drop into the cylinder, an overhaul is required.

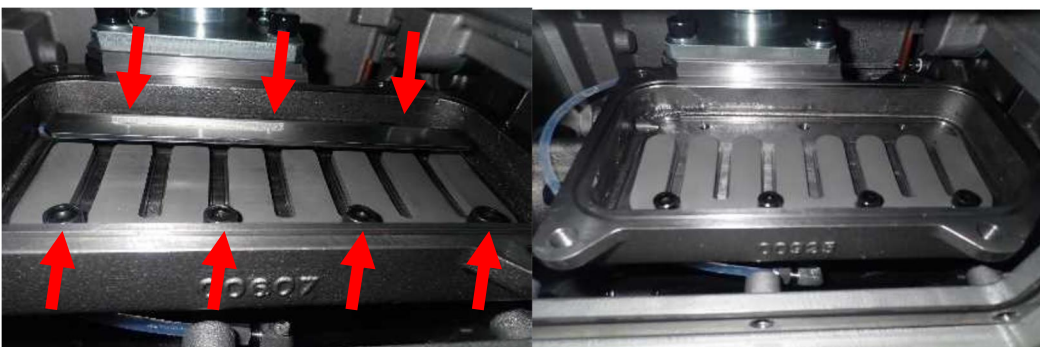

5. Replace the exhaust valve plate and fix the exhaust valve guide. At this time, place all the exhaust valve plates to close the exhaust port first and then install the bolts. This prevents bolts and spring washers from dropping into the cylinder through the exhaust port. If any parts drop into the cylinder, an overhaul is required. In addition, the tightening torque of the bolts is 30 N · m. Then install the Z-type oil fence. Also the tightening torque of these bolts is 30 N · m.



6. Then install the other parts in reverse order.

6.2.6 Cleaning of oil tank

The sucked foreign matter, products, sludge of pump oil, etc. are accumulated inside the oil tank. If the amount of deposit increases, it cannot be removed only by changing oil, which may cause damage to the pump as the contaminated/degraded pump oil is used for lubrication. In reference to "Table 9: Guideline for oil change interval" on page 53, open the oil tank, and remove and clean the deposit.

■Cleaning of oil tank

1. Stop the pump.
2. Remove the red-circled cover of the oil tank.

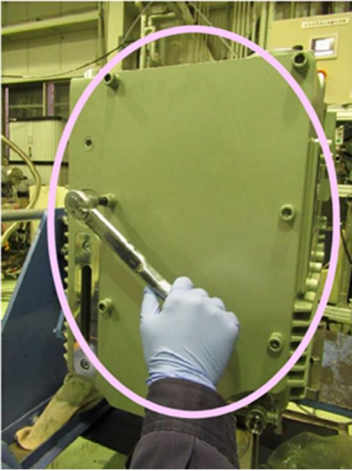

3. Scrape out the foreign matter, products, sludge of pump oil, etc. accumulated in the oil tank.

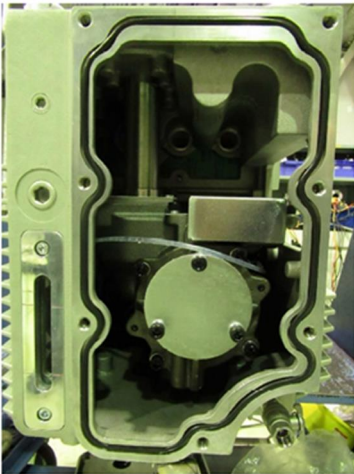

4. Install the cover in reverse order.
5. Add the specified amount of oil. Operate the pump and check whether or not the oil level is within the range of the oil gauge.

6.2.7 Inspection of automatic drain valve

If the ultimate pressure does not drop from several hundred Pa or so, it can be a fault in the automatic drain valve. Monitor the ultimate pressure as daily inspection and, if the ultimate pressure does not decrease, make an inspection.

■ How to inspect the automatic drain valve

1. Stop the pump.
2. Remove the circled cover of the oil mist separators shown below.



3. Remove the two internal circled bolts and remove the two oil mist separators indicated by the arrows. In addition, oil deposited on the oil mist separators streams down. Therefore, when removing the oil mist separator unit, it is recommended to put an oil pan on the floor.

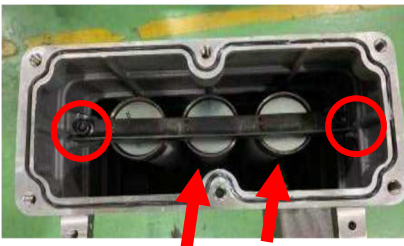

4. Pull out the automatic drain valve in the direction of the arrow.

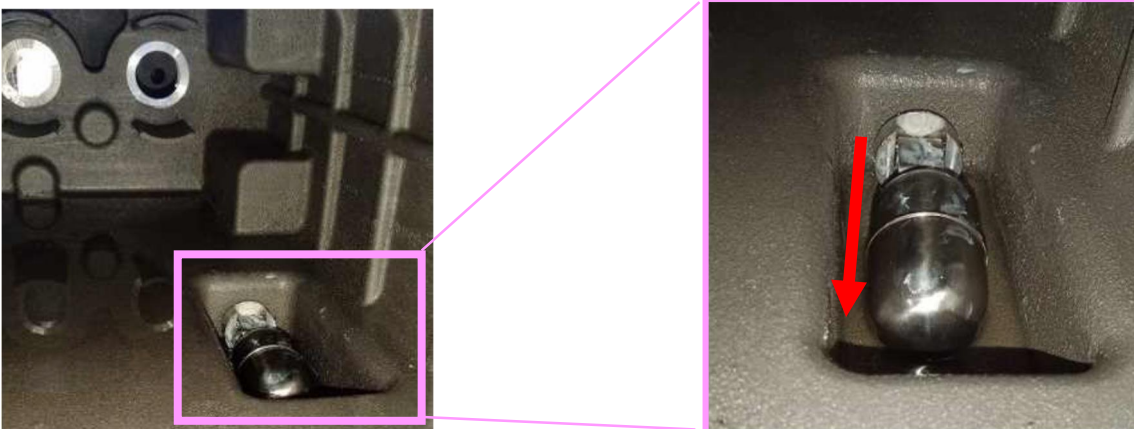

- Carefully wipe off any deposits. Take special care when wiping off the rubber seal part of the sealing section.



- After wiping it off, install the automatic drain valve. Install in the direction that the float section moves upward as shown in the photo. At this time, take care not to scratch the O-ring.



- Install the other parts in reverse order.

6.2.8 Replacement of oil filter

This pump comes equipped with an oil filter as standard. The oil filter removes impurities contained in oil that circulates in the pump. If the amount of oil circulation is reduced due to a clogged oil filter, it may cause failures such as rapid wear or seizing up of the parts. This is highly likely to occur especially in high pressure regions. Take care.

Replace the oil filter in reference to "Table 9: Guideline for oil change interval" on page 53.

■ How to replace the oil filter

1. Stop the pump.
2. With the oil tank at the front, remove the four screws that fix the left panel and remove that panel.



3. The oil filter is removed when turned in the direction of the arrow. Note that oil leaks out of the oil filter. Therefore, when removing the filter, it is recommended to prepare an oil pan on the floor. (It is recommended to use a belt wrench.)



If the double union is removed together with the filter, remove the double union and attach it to a new filter.

4. Install the new oil filter to the oil tank. Apply pump oil onto the O-ring section of the oil filter before tightening it into the pump body. Tighten it by hand as much as possible and then additionally tighten a 3/4 turn using a belt wrench.

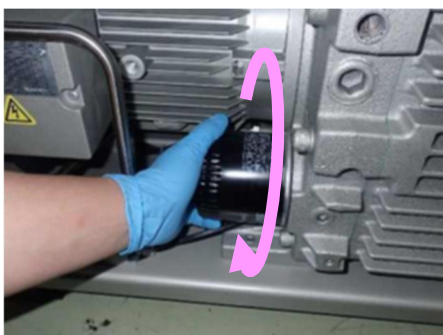

5. Add the specified amount of oil into the pump from the oil filler port. Operate the pump and check whether or not the oil level is within the range of the oil gauge.
6. Install the other parts in reverse order.

6.2.9 Maintenance and cleaning of heat exchanger

This unit uses cooling water to cool down oil circulating in the pump in a heat exchanger. If the heat exchanger is clogged with impurities, such as scale and iron, the amount of cooling water decreases, causing failures such as rapid wear or seizing up of the parts. When using cooling water with a large amount of impurities, such as scale and iron, filter them with a filter installed in the prior stage before use. Perform maintenance and cleaning of the heat exchanger once a year.

■ Maintenance

During maintenance, supply a flow rate of 1.2 times or more the steady flow rate for a few minutes to discharge foreign matter inside the heat exchanger. Feeding compressed air at the same time increases the effect.

■ Cleaning of heat exchanger

If the flow rate drops or the pressure loss increases, blow compressed air or fresh water vigorously from the cooling water pipe outlet to forcibly discharge foreign matter inside. (Pressure of compressed air or fresh water: 1.0 MPaG or less)

If the flow rate and pressure loss do not recover even after taking the above measures, contact your nearest service center for replacement.

6.2.10 Inspection of oil drain port (Drain valve)

If the oil drain port (drain valve) is left half open for several months, the seal section may deform, causing it not to be fully closed. When storing it, make sure the valve is fully closed. Check it as well even when the valve is closed with a plug.

Inspect the oil drain port (drain valve) in reference to "**Table 9: Guideline for oil change interval**" on page 53.

▶ 6.3 Inspection after Long-Term Storage

If this pump is stored for a long period of time without being operated (at least six months), trouble may occur when the pump is operated due to rusting.

If the pump has not been used for a long period of time, request an inspection from your local ULVAC service center before using the pump.

▶ 6.4 Overhaul

If the pump is contaminated or its performance deteriorates to the significant extent due to the operating conditions, it is recommended to overhaul it regularly.

Overhauls are necessary to maintain the performance (including safety) and to continue scheduled production.

	WARNING	<u>When exhausting dangerous gases or substances, ask a specialized company to detoxify it.</u>
		When exhausting dangerous gases or substances and then overhaul or dispose of them, ask a specialized waste disposal company to detoxify it.
	CAUTION	<u>Perform an overhaul once a year.</u>
		Perform an overhaul once a year. In addition, an overhaul is recommended when this pump's performance degraded significantly or it has been contaminated by the usage, even when less than a year has passed since the previous overhaul.

For overhauls, contact your local ULVAC Service center. When requesting overhaul, maintenance, repair, or other work, fill out the Declaration of Contamination attached to this manual and submit it to the service center.

If details on the dangerous substances in use is not disclosed or if difficult-to-detoxify substances are exhausted, the Service center may refuse to perform maintenance or other operations.

▶ 6.5 Notes on Pump Transportation

This product is a precision machine that incorporates precision machinery components and electronic components inside. Application of a strong impact or continuous vibration may cause a malfunction. Therefore, in transportation, please use a means of transportation which have vibration-proof function (an air suspension truck, for example).

Especially for long-distance overland transportation under poor road surface conditions, it is recommended to transport to the installation site under the same packing condition as when it was shipped from ULVAC.

If it is left in a high temperature and high humidity environment for a long time, it may cause a malfunction due to corrosion of mechanical parts or performance deterioration of electrical parts. Transport and store in an appropriate environment.

7. Troubleshooting

▶ 7.1 Trouble with Basic Operation

Table 10: Trouble with Basic Operation

Problem	Cause	Measures	Reference
The pump does not rotate.	The motor is not properly wired.	Check wiring connection.	3.7.1
	The safety circuits are not set correctly.	Adjust the safety circuits to the motor specifications.	3.7.1
	Deteriorated oil increased its viscosity.	Change oil.	6.2.1
	Foreign matter entered the pump and the rotors or other components seized up.	Contact your nearest service center. (Replacement of cylinders, rotors, vanes, and covers)	End of Doc.
	After exhausting the reactive gas, reaction products was built up inside the pump while it was stopped.	Contact your nearest service center. (Cleaning inside the pump, removal of reaction products)	End of Doc.
	Not connected to power supply.	Connect to the power supply.	3.7.1
	The power switch is not ON.	Turn ON the power switch.	-
	Abnormal voltage of input power supply	Set the voltage within the range of the rated voltage of $\pm 5\%$ (Variation: up to $\pm 10\%$).	-
	The overload protector is activated.	Press the reset button that eliminates the cause why the overload protector was activated.	-
	The safety circuits are faulty.	Inspection/Replacement of safety circuits	-
	Faulty motor	Contact your nearest service center. (Replacement of motor)	End of Doc.
	Moisture, solvents, or other substances were sucked in and built up inside the pump. / Rust occurred.	Contact your nearest service center. (Cleaning inside the pump, removal of reaction products)	End of Doc.
	Moisture, solvents, or other substances were sucked in and vane swelling occurred.	Contact your nearest service center. (Replacement of vanes, checking/replacement of cylinders/rotors)	End of Doc.
	In addition, the internal parts of the pump were damaged.	Contact your nearest service center. (Replacement of damaged parts)	End of Doc.
	The ambient temperature is low.	Jog the pump (short-time ON-OFF operation) several times. / Warm up oil. / Start while performing a slow leak and operate for several minutes.	3.1.3 3.5
	After the pump stopped, it was not released to the atmosphere.	Jog the pump (short-time ON-OFF operation) several times	4.3.2
	The specified amount of oil is not contained. The oil level is outside the range of the oil level gauge. a. Oil leakage outside the pump b. Oil entry into a pump cylinder	Control the oil level. Add the specified amount of oil. a. Contact your nearest service center. (Replacement of O-rings) b. Jog the pump (short-time ON-OFF operation) several times	End of Doc. 3.5
	The power capacity is short.	Secure the recommended power capacity.	3.7.1
The thermostat tripped.	Make sure that the pump temperature is low enough and that the power to the pump is turned off, and then remove the panel and press down the protrusion at the center of the thermostat.	3.7.2	

Problem	Cause	Measures	Reference
Abnormal noise is occurring.	The motor rotates in the opposite direction.	Connect wires again so that it rotates in the correct direction.	3.7.1 4.2.1
	The pump continuously operates at high suction pressures.	The noise becomes louder when operating at high suction pressure. In such a case, make an pressure adjustment.	-
	The specified amount of oil is not contained. The oil level is outside the range of the oil level gauge.	Control the oil level. Add the specified amount of oil. If the abnormal noise does not stop, contact your nearest service center. (Replacement of cylinders, rotors, vanes, and covers)	3.5 End of Doc.
	There is foreign matter in the pump.	Contact your nearest service center. (Removal of foreign substances, Replacement of damaged parts)	End of Doc.
	The specified amount of cooling water does not flow.	Supply the specified amount of cooling water. If the abnormal noise does not stop even after supplying cooling water, contact your nearest service center.	3.6.3 End of Doc.
	Oil does not circulate. a. An oil hole is clogged. b. The oil filter is clogged.	a. Contact your nearest service center. (Cleaning of oil hole) b. Replacement of oil filter	End of Doc. 6.2.8
	The vanes do not work. a. There are deposits on the vane. b. Vane swelling	Contact your nearest service center. a. Cleaning the deposits on the vanes b. Replacement of vanes	End of Doc.
	In addition, the internal parts of the pump were damaged.	Contact your nearest service center. (Replacement of damaged parts)	End of Doc.
	The screws on the panel is loosened.	Tighten the screws.	-
	There is a "clattering" sound when starting/stopping the unit.	The phenomenon caused by the temporary irregular movement of the vanes in the pump, with no particular problems.	-
	The bolts for the footing bolts (base unit) are loosened.	Additionally tighten the bolts.	-
	The installation surface is uneven.	Install on a horizontal surface.	3.4
	The slow leak valve is clogged.	Contact your nearest service center. (Replacement of the slow leak valve)	End of Doc.
Oil punch noise (operation at the ultimate pressure)	When it is fixed by adjusting the slow leak valve, it is not abnormal.	3.6.5	
The performance is satisfied in early stages but the ultimate pressure is getting worse.	Oil is deteriorated. a. Moisture system is evacuated. b. Dust is evacuated. c. Solvent fume is sucked in. d. Foreign matter enters.	Change oil. a. Insert a trap into the prior stage of the pump. b. Insert a filter/trap into the prior stage of the pump. c. Insert an application-specific trap into the prior stage of the pump. d. Insert a filter into the prior stage of the pump.	6.2.1
	There is leakage in piping connecting the pump.	Locate the leak point using a leak detector or other detectors for leakage and stop the leak.	-
	Just after new oil has been added	Operate at no load for a while.	-
	Oil does not circulate. a. An oil hole is clogged. b. The oil filter is clogged.	a. Contact your nearest service center. (Cleaning of oil hole) b. Replacement of oil filter	End of Doc. 6.2.8
Pressure does not drop.	The displacement of the pump is lower than the amount of the vacuum chamber.	Pump reselection	-

Problem	Cause	Measures	Reference
	The method of measuring pressure is incorrect.	Measure the pressure in the correct way.	2.3.1
	The vacuum gauge is not appropriate.	Measure using a vacuum gauge that matches the pressure range to be measured and is calibrated correctly.	2.3.1
	The connection pipe for the inlet port is thin or the piping distance is long.	Connect with a pipe larger than the inlet port diameter to shorten the distance to the vacuum chamber.	3.6.1
	The wire mesh in the inlet port is clogged.	Remove the piping at the top of the inlet port and clean the wire mesh.	-
	The specified amount of oil is not contained. The oil level is outside the range of the oil level gauge.	Control the oil level. Add the specified amount of oil.	3.5
	Oil is deteriorated. a. Moisture system is evacuated. b. Dust is evacuated. c. Solvent fume is sucked in. d. Foreign matter enters.	Change oil. a. Insert a trap into the prior stage of the pump. b. Insert a filter/trap into the prior stage of the pump. c. Insert an application-specific trap into the prior stage of the pump. d. Insert a filter into the prior stage of the pump.	6.2.1
	There is leakage in piping connecting the pump.	Locate the leak point using a leak detector or other detectors for leakage and stop the leak.	-
	Our genuine oil is not used.	Contact your nearest service location. (After an overhaul, replace with our genuine oil.)	End of Doc.
	Just after new oil has been added	Operate at no load for a while.	-
	The gas ballast valve / leak valve is open.	Close the gas ballast valve / leak valve.	3.6.4
	The motor rotates in the opposite direction.	Connect wires again so that it rotates in the correct direction.	4.2.1
	Oil does not circulate. a. An oil hole is clogged. b. The oil filter is clogged.	a. Contact your nearest service center. (Cleaning of oil hole) b. Replacement of oil filter	End of Doc. 6.2.8
	Water is mixed in the pump.	Change oil.	6.2.1
	The automatic drain valve does not work properly.	Check the automatic drain valve.	6.2.7
	The exhaust valve plate is broken.	Replace the exhaust valve plates.	6.2.5
	Pump does not rotate.	Check the electric wiring.	3.7.1
	The storage flange is left attached to the inlet port.	Remove the storage flange.	-
	The specified amount of cooling water does not flow.	Supply the specified amount of cooling water. If the abnormal noise does not stop even after supplying cooling water, contact your nearest service location.	3.6.4 End of Doc.
Oil level gauge comes out.	The piping in the posterior stage is clogged.	Install the piping larger than the exhaust port diameter. In addition, check whether or not it is blocked.	3.6.1 6.2.4
The temperature on the pump surface is abnormally high.	The pump continuously operates at high suction pressures.	Continuous operation at high suction pressures results in a high temperature on the pump surface. Therefore, adjust the pressure.	-

Problem	Cause	Measures	Reference
	The specified amount of oil is not contained. The oil level is outside the range of the oil level gauge. (A small amount of oil reduces the cooling effect of the pump.)	Control the oil level. Add the specified amount of oil.	3.5
	Oil is deteriorated. a. Moisture system is evacuated. b. Dust is evacuated. c. Solvent fume is sucked in. d. Foreign matter enters.	Change oil. a. Insert a trap into the prior stage of the pump. b. Insert a filter/trap into the prior stage of the pump. c. Insert an application-specific trap into the prior stage of the pump. d. Insert a filter into the prior stage of the pump.	6.2.1
	Suction gas is at a high temperature.	Install a gas cooler or another cooling device on the inlet side.	-
	The area surrounding the pump is sealed.	Provide ventilation.	3.4
	The ambient temperature is high.	Use in an air-conditioned environment.	3.1.3
	There is leakage in piping connecting the pump.	Locate the leak point using a leak detector or other detectors for leakage and stop the leak.	-
	Oil does not circulate. a. An oil hole is clogged. b. The oil filter is clogged.	a. Contact your nearest service center. (Cleaning of oil hole) b. Replacement of oil filter	End of Doc. 6.2.8
	The gas ballast valve / leak valve is open.	Close the gas ballast valve / leak valve.	-
	The specified amount of cooling water does not flow.	Supply the specified amount of cooling water. If the abnormal noise does not stop even after supplying cooling water, contact your nearest service location.	3.6.4 End of Doc.
Pump vibrates.	The bolts for the footing bolts (base unit) are loosened.	Additionally tighten the bolts.	-
Oil leaks outside the pump.	Deterioration of the oil tank, O-rings of cylinders, oil seals.	Contact your nearest service center. (Inspection/Replacement of O-rings, oil seals)	End of Doc.
	Looseness of a plug such as for the oil filler port.	Re-tighten the plug.	-
	The oil drain port (drain valve) is open.	Close the oil drain port (drain valve).	-
Oil leaks outside the pump.	Deterioration of the seal gasket.	Re-coating of the seal gasket. Contact your nearest service center. (Inspection of cooling water system)	-
	Looseness of joints in the cooling water system.	Inspection of joints in the cooling water system. Contact your nearest service center. (Inspection of cooling water system)	-
A lot of oil smoke blows out from the exhaust port.	The specified amount of oil or more is contained.	Drain oil so that the oil level is adjusted to the specified amount.	6.2.1
	Continuous operation at a high suction pressure.	Adjust the pressure.	-
	The exhaust valve plate is broken.	Replace the exhaust valve plates.	6.2.5
	Clogged oil mist separators.	Replace the oil mist separators.	6.2.4

8. Specifications

▶ 8.1 Performance Specifications

Model			VS300A-W
Designed pumping speed	50Hz	m ³ /hr (L/min)	250(4166)
	60Hz		300(5000)
Ultimate pressure *1	GP Close	Pa	≤ 15
	GP Open		≤ 200
Power consumption (At ultimate pressure)	50Hz	kW	2.8
	60Hz		3.1
Motor	Model		Totally enclosed fan cooled 3 phase induction motor
	Capacity	kW(Poles)	7.5(4)
	Voltage *2 *3	50Hz	200~240V/380~415V
60Hz		200~240V/380~460V	
Noise level	At ultimate pressure	50Hz	70.1dB(A)*5 / 72.9dB(A)*6
		60Hz	74.2.dB(A)*5 / 76.7dB(A)*6
Oil for use			ULVOIL R-72 *4
Required amount of oil		L	10~15
Cooling method			Water cooled
Cooling water	Primary pressure	MPaG	≤ 0.3
	Differential pressure between inlet and outlet	MPaG	≥ 0.1
	Amount of cooling water	L/min	≥ 3.0
	Cooling water temperature (°C)	°C	5~30
	Cooling water Δt	°C	≤ 25
Inlet port flange			DN 63 ISO-F
Exhaust port flange			G2 female
Weight		kg	270
External dimensions W×D×H		mm	404×871×585
Overseas safety standards			CE, cTUVus

Model	VS300A-W
Usage environment	Overvoltage category II Pollution Degree 2
Options and accessories *7	<ul style="list-style-type: none"> • Inlet port VG flange (VG80) • Inlet port NW flange (NW80) • Exhaust port NW flange (NW50) • Fitting nipple for exhaust port hose (G2 -> Nominal diameter: $\phi 50$) • Pressure gauge for monitoring pump internal pressure monitoring • Casters • Adjuster feet • External gas ballast valve

CAUTION: This catalog uses the International System of Units.

*1: Measured using a Pirani gauge.

*2: The factory default is a 200-V-class Δ connection.

If you use a 400-V-class voltage, change it to a Y connection before use.

*3 Set the voltage within the range of the rated voltage of $\pm 5\%$ (Variation: up to $\pm 10\%$).

*4: ULVOIL R-7 can also be used.

When changing to R-7 or R-72, drain the old oil as much as possible and then add new oil.

*5: The average sound pressure level measured and calculated based on ISO 2151.

*6: The maximum value measured based on ISO 2151.

*7: Accessories are included when shipped.

If a conversion flange is used for the inlet/exhaust port, the dimensions of the piping connection change.

► 8.2 External Dimensions

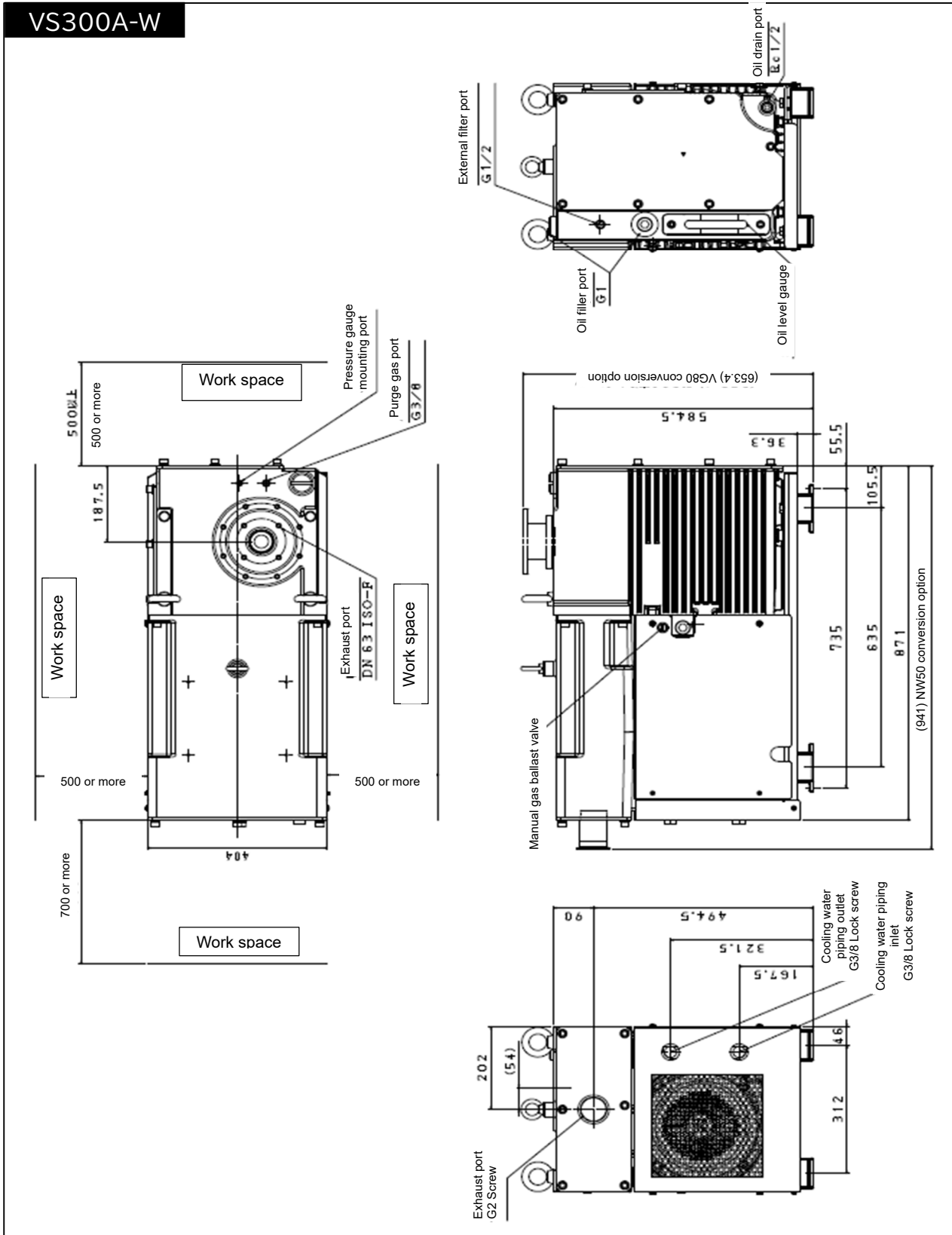

Figure 21: External dimensions of VS300A-W

Appendix

Major replacement parts

The list of parts to be replaced through an overhaul is shown below: The replacement period depends on the part. In addition, the recommended replacement cycle shown in the table below is given for reference only. It depends on your usage and environment.

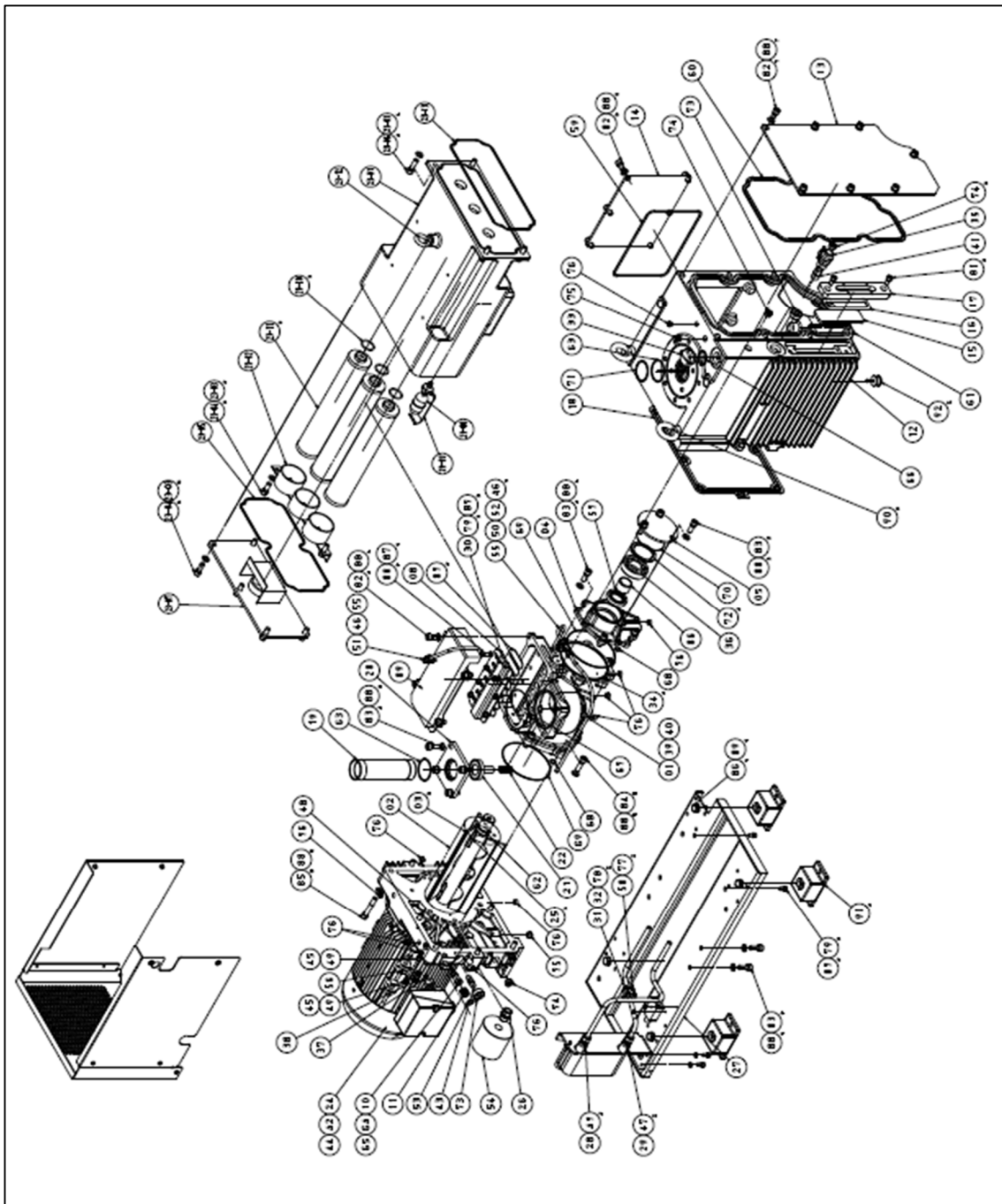

Figure 22: Overall bird's eye view

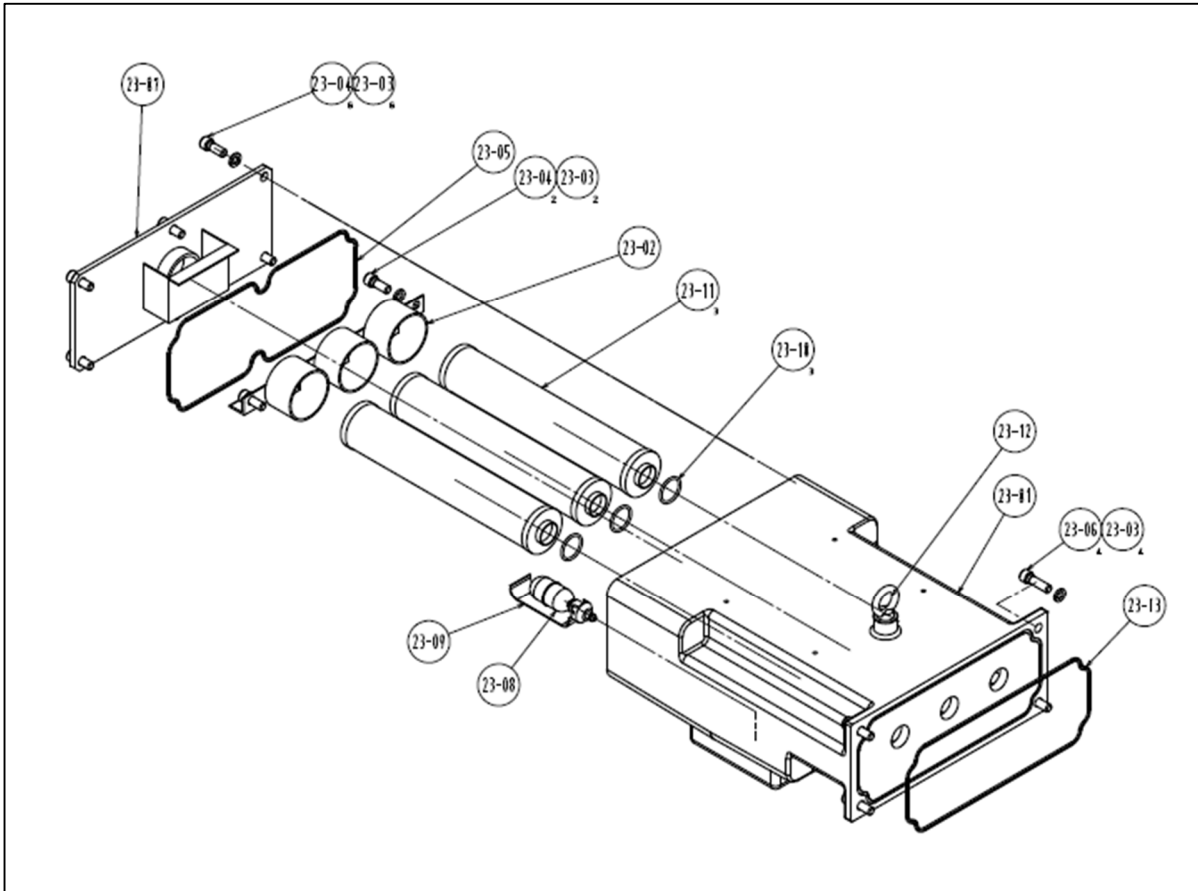

Figure 23: OMS Box assembly drawing

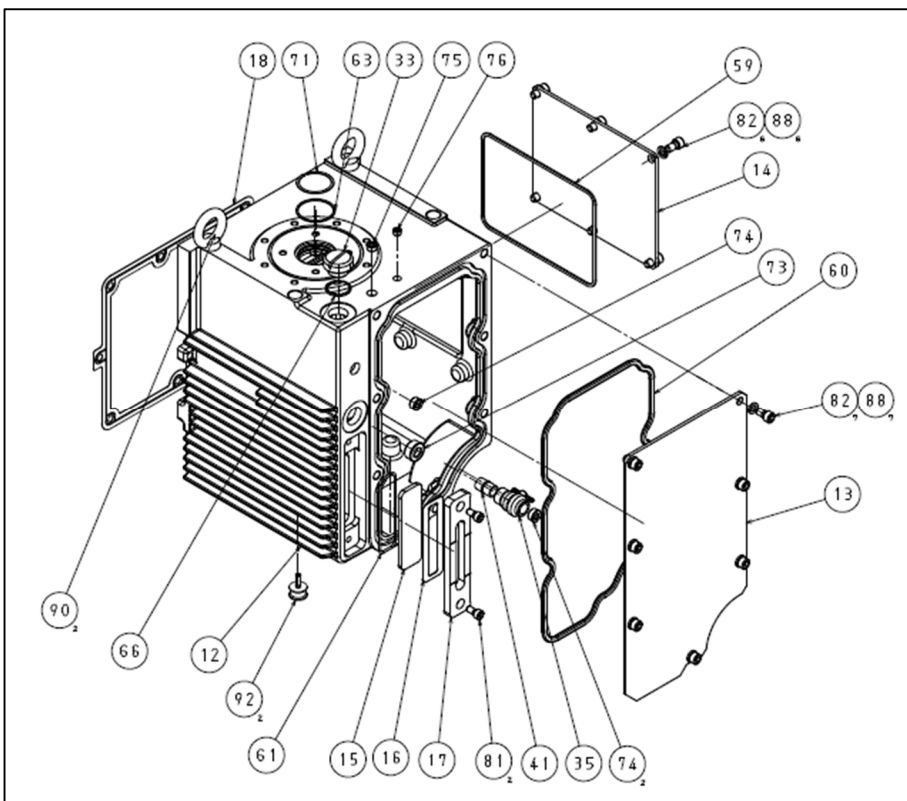

Figure 24: Oil tank assembly drawing

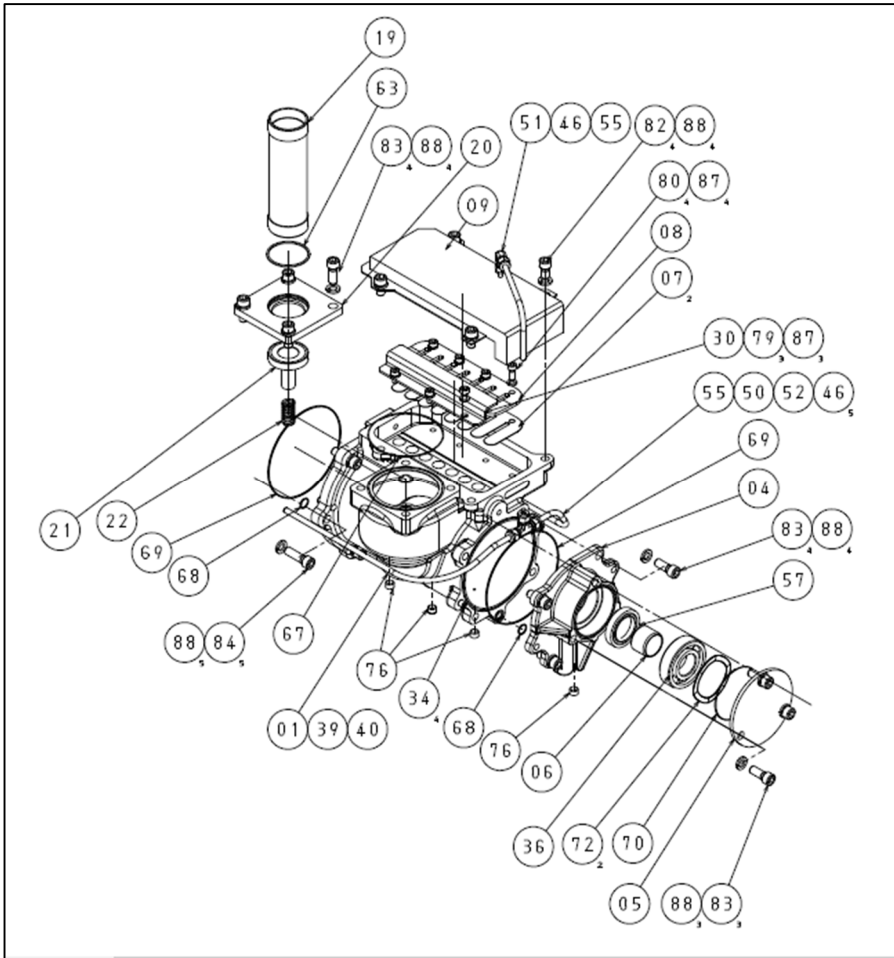

Figure 25: Pump unit assembly drawing

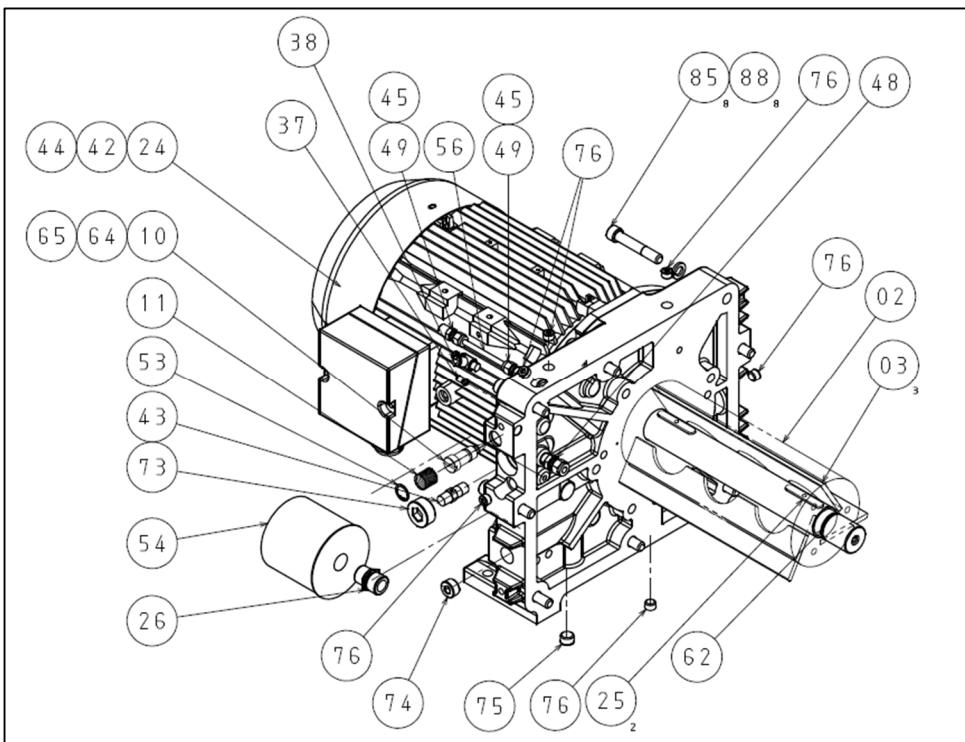

Figure 26: Motor unit assembly drawing

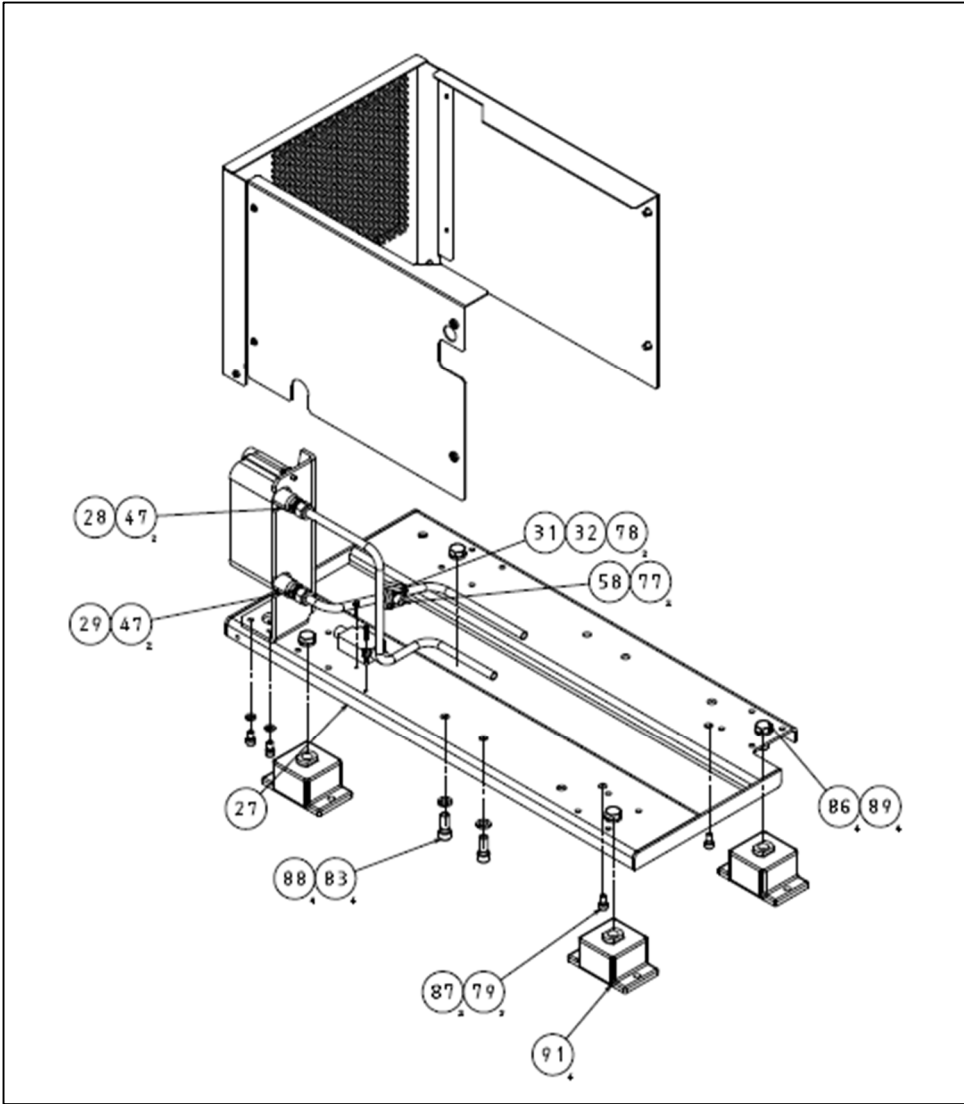

Figure 27: Base unit assembly drawing

Table 11: Parts list

Code	Number of configurations	Item name	Material	Dimensions
01	1	1st cylinder		
02	1	1st pump Rotor		
03	3	1st vane		
04	1	Rear side-cover		
05	1	Rear cover		
06	1	Seal sleeve 29		
07	2	Exhaust valve plate		
08	1	Exhaust valve guide		
09	1	Exhaust baffle		
10	1	Gas ballast valve		
11	1	Gas ballast spring		
12	1	Oil tank		
13	1	Oil tank cover 1		
14	1	Oil tank cover 2		
15	1	Oil level gauge glass		
16	1	Oil level gauge gasket		
17	1	Oil level gauge cover		
18	1	Oil tank gasket		
19	1	Inlet tube		
20	1	Inlet flange		
21	1	Anti-suction valve		
22	1	Anti-suction spring		
23	1	Oil mist separator unit		
23-01	1	Oil mist separator box		
23-02	1	Oil mist separator support		
23-03	12	Spring washer		M12
23-04	8	Hexagon socket head bolt		M12x30
23-05	1	O-ring:	FKM	AS568-279
23-06	4	Hexagon socket head bolt		M12x40
23-07	1	Oil mist separator cover		
23-08	1	Auto discharge drain valve		
23-09	1	Drain valve stopper plate		
23-10	3	O-ring:	FKM	P35
23-11	3	Oil mist separator		
23-12	1	Eyebolt		M12
23-13	1	O-ring:	FKM	AS568-277
24	1	Motor unit		
25	2	Rotor key		
26	1	Different-diameter threaded nipple		
27	1	Base unit (water cooling)		
28	1	Oil tube inlet (water cooling)		
29	1	Oil tube outlet (water cooling)		
30	1	Z-type oil fence		
31	1	Pipe clamp 1		
32	1	Pipe clamp 2		
33	1	Seal plug		
34	4	Parallel pin		
35	1	Ball valve		
36	1	Bearing		6307 C3
37	1	Silencer		
38	1	Slow leak valve		
39	1	Bush		

Code	Number of configurations	Item name	Material	Dimensions
40	1	Bush		
41	1	Hexagon nipple		R1/2
42	1	Socket		3/8B
43	1	Check valve		
44	1	Check valve		
45	2	Insert		O.D6、I.D4
46	2	Insert		O.D8、I.D6
47	4	Male connector		R3/8 ϕ 12
48	1	Male connector		R1/4 ϕ 8
49	2	Male connector		R1/4 ϕ 6
50	1	Male elbow		R1/4 ϕ 8
51	1	Reducing union elbow		ϕ 8- ϕ 6
52	1	Union tee		ϕ 8
53	1	C-type hole snap ring		ϕ 20
54	1	Oil filter		
55	3	Tube		O.D8、I.D6
56	1	Tube		O.D6、I.D4
57	1	Oil seals		
58	1	Thermostat		
59	1	O-ring	FKM	AS568-276
60	1	O-ring	FKM	E4250G
61	1	O-ring	FKM	G115
62	1	O-ring	FKM	G30
63	2	O-ring	FKM	G60
64	1	O-ring	FKM	P12
65	1	O-ring	FKM	P7
66	1	O-ring	FKM	P36
67	1	O-ring	FKM	S110
68	2	O-ring	FKM	S14
69	2	O-ring	FKM	S150
70	1	O-ring	FKM	S85
71	1	Retaining ring		O.D62、I.D54 t0.8
72	2	Wave washer		O.D78、I.D61
73	2	Hexagon socket head tapered plug		R1B type (Sunk)
74	3	Hexagon socket head tapered plug		R1/2 B type (Sunk)
75	2	Hexagon socket head tapered plug		R3/8 B type (Sunk)
76	11	Hexagon socket head tapered plug		R1/4 B type (Sunk)
77	2	Hexagon socket head bolt		M3x5
78	2	Hexagon socket head bolt		M5x22
79	5	Hexagon socket head bolt		M8x15
80	4	Hexagon socket head bolt		M8x20
81	2	Hexagon socket head bolt		M10x20
82	17	Hexagon socket head bolt		M12x20
83	15	Hexagon socket head bolt		M12x30
84	5	Hexagon socket head bolt		M12x40
85	8	Hexagon socket head bolt		M12x70
86	4	Hexagon head bolt		M14x35
87	9	Spring washer		M8
88	45	Spring washer		M12
89	4	Spring washer		M14
90	2	Eyebolt		M20_EB
91	4	Vibration-proof rubbers		120×76×53

Code	Number of configurations	Item name	Material	Dimensions
92	2	Vibration-proof rubbers		$\phi 30 \times 18$
93	1	Grease		

Table 12: Replacement parts list for overhaul

Code	Number of configurations	Item name	Material	Dimensions
1st cylinder	2	O-ring:	FKM	S14
	1	O-ring:	FKM	S110
	2	O-ring:	FKM	S150
Rear side-cover	1	O-ring:	FKM	S85
	1	Oil seals	FKM	
	1	Bearing		6307 C3
	2	Wave washer		O.D78, I.D61
Rear cover	1	Seal sleeve 29		
	1	O-ring:	FKM	G30
Gas ballast valve parts	1	O-ring:	FKM	P7
	1	O-ring:	FKM	P12
	1	Gas ballast gas tube		O.D8, I.D6
	1	Male connector		R1/4 ϕ 8
	1	Male elbow		R1/4 ϕ 8
	1	Union tee		ϕ 8
	5	Insert		O.D8, I.D6
	Oil tank	1	O-ring:	FKM
1		O-ring:	FKM	AS568-276
1		O-ring:	FKM	G115
1		O-ring:	FKM	G60
1		O-ring:	FKM	P36
1		Oil level gauge gasket		t0.8
1		Oil tank gasket		
Inlet port flange	1	O-ring:	FKM	G60
Anti-suck valve	1	O-ring:	FKM	V20
Oil mist separator unit	1	O-ring:	FKM	AS568-279
	3	Oil mist separator		
	3	O-ring:	FKM	P35
	1	O-ring:	FKM	P7
	1	O-ring:	FKM	AS568-277
Front side cover	2	Oil seals	FKM	
	1	Bearing		6308ZZ C3
Motor unit	1	Motor back cover		7.5kW4P
	1	Bearing		6308ZZ C3
	2	Wave washer	Steel for springs	O.D88.5, I.D69
	1	Oil filter		
	10~15L	Oil	Mineral oil	ULVOIL R-72

Table 13: 8000-hour replacement parts list

Code	Number of configurations	Item name	Material	Dimensions
1st cylinder	2	Exhaust valve plate		
	1	Exhaust valve guide		

Table 14: Replacement parts due to scratches or clogging

Code	Number of configurations	Item name	Material	Dimensions
Base unit	2	Vibration-proof rubbers		$\phi 30 \times 18$
	2	Hexagon socket head bolt		M8x15
	2	Spring washer		M8, MFZn II
	4	Vibration-proof rubbers		120x76x53
	4	Hexagon head bolt		M14x35
	4	Spring washer		M14, MFZn II
Anti-suction valve	1	Anti-suction valve		
	1	Anti-suction spring		
Vane	3	1st vane		
Oil mist separator unit	1	Tube		O.D6, I.D4
	2	Male connector		R1/4 $\phi 6$
	2	Insert		O.D6, I.D4
Gas ballast valve parts	1	Gas ballast gas tube		O.D8, I.D6
	1	Male connector		R1/4 $\phi 8$
	1	Male elbow		R1/4 $\phi 8$
	1	Union tee		$\phi 8$
	5	Insert		O.D8, I.D6
	1	Gas ballast filter		

ULVAC Components / Certificate of Decontamination

This is a certificate of decontamination for repair and inspection request of ULVAC Components. All material must be certified as decontaminated and this certificate must be submitted to your closest local ULVAC service center or sales office prior to shipment.

Please consult with your closest local ULVAC service center or sales office if our components are used with toxic gases or contaminated with reactive products or substances produced by reaction.

Product model:

Model:

Serial No.:

Application:

Remarks: _____

Contaminant (Check an applicable box.)

- I guarantee that above returned item(s) is not contaminated with harmful substances.
- Above returned item(s) is contaminated with the following harmful substances.

	Name of contaminant (molecular formula)	Characteristics
1		
2		
3		
4		
5		

To: ULVAC, Inc

Attn: _____

Date: / / (YYYY/MM/DD)

Your company _____
 Division _____
 Contact _____
 Phone _____
 Fax _____
 E-mail _____

Please pack returned item(s) carefully before shipment. Any accident occurred during transportation to us caused by contaminant is under your responsibility. It is also to be understood that ULVAC may decline to repair returned item(s) depending on the type of contaminant and degree of contamination, and return it to you.

To be filled in by ULVAC Request for MSDS: Yes/No	Received by	
ULVAC job No.		

ULVAC ,Inc.
Components Business HQ
<https://showcase.ulvac.co.jp/en/>

Please contact us for products, Service Base or other Inquiries from here.



showcase.ulvac.co.jp/en

ULVAC, Inc.
Sales Department, Components Business HQ
2500 Hagisono, Chigasaki, Kanagawa, 253-8543, Japan
TEL: +81-467-89-2261

