

INSTRUCTION MANUAL

Controller For UTM-MS Series

Suitable pump

UTM800A-MS

UTM1000A-MS

UTM1300A-MS

UTM1500A-MS

Before using this product, be sure to read this operation manual.

Keep this manual with care to use at any time.

ULVAC KIKO, Inc.

No Text

Introduction

Thank you for choosing the controller for Turbo Molecular Pump (hereafter referred to as "controller"). Please read this instruction manual carefully before using the controller, and save the instruction manual for future reference.

This instruction manual explains detailed operations of the controller and cables. For instructions regarding the pump unit, please refer to the instruction manual for the pump unit to be used.

Standard type is explained in this manual. For special order type, please refer to the outlines and constructions of each specification.

Copyrights and Disclaimers

This document is copyrighted by ULVAC KIKO, Inc. . Please refrain from reproducing or copying part or all of this document without permission from ULVAC KIKO.

In an effort to improve the product, this document may be revised in the future without notice.

Every effort has been made to prepare an accurate and complete manual, but if an error or omission should be discovered, revisions might not be possible immediately.

ULVAC KIKO does not take responsibility for any effects that may result from the use of this manual.

Precautions for Safe Operation

The instruction manual's nomenclature for warnings and precautions complies with the following safety warning symbols.

WARNING

Indicates a potentially hazardous situation which, if not avoided, could result in serious injury or possibly death.

CAUTION

Indicates a potentially hazardous situation which, if not avoided, may result in minor to moderate injury or equipment damage.

NOTICE

Emphasizes additional information that is provided to ensure the proper use of this product.

WARNING

Turbo molecular pump repair and/or controller repair can be very hazardous. Only trained technicians who are authorized by ULVAC KIKO may do service of products.



WARNING

Neither overhaul nor modify the pump proper and controller without admission. Doing so would impair safety of the pump proper, or cause injury by electrical shock.



WARNING

Decisions on system compatibility should be made by the system designer or the person deciding the specifications after conducting tests as necessary. The responsibility for guaranteeing the expected performance and safety of the system lies with the person who decides system compatibility.

CAUTION

The standard power input voltage of the controller is 200 to 240 VAC. Connect the controller to the voltage indicated on the side panel label only. Connection of the controller to the incorrect input voltage can cause damage to the equipment. Controller via a circuit breaker (rating 15 A). Please provide PE (Protective Earth) connection to the terminal of a "PE" marked wire in final application. When power cable whose length is longer than 5 m is used to input AC power, protective earth line has to be connected to the PROTECTIVE EARTH TERMINAL (Fig. 2-2 (20)) which is on rear panel of the controller with the cable which has shorter than 5 m and thicker than AWG14.

CAUTION

If a controller is used in combination with an existing pump that was operated in combination with a controller not having the variable speed function, the variable speed function cannot be used (the "xx" number indicates the model of the corresponding pump).

If the controller is to be combined with an existing pump, modification and operational inspections are necessary. Please contact ULVAC KIKO for detailed information.

CAUTION

The following "CAUTIONS" are to prevent operation anomalies.

○ Operating Precautions

- (1) Do not interrupt the electrical power operating the turbo molecular pump while the turbo molecular pump is in operation.
 - (2) Do not connect or disconnect the turbo molecular pump control cable during the time the controller is "ON".
 - (3) Do not operate any equipment (i.e. drill motor, welding machine, etc.) that produces electro-magnetic pollution, noise, etc., in the immediate proximity of an operating turbo molecular pumping system (pump, controller, cables, etc.).
 - (4) When using the variable speed function to change the pump rotation rate, use a rotation rate that does not cause resonance with other devices installed at the site.
 - (5) Be careful to prevent a rapid pressure rise or air rush during operation.
-
-

NOTICE

Guaranteeing the expected performance covers only a combination of TMPs and controllers sold by ULVAC KIKO.

○ Explanation of Label

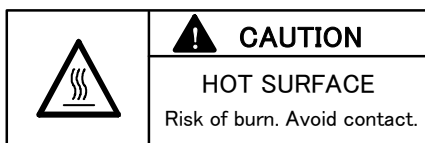

(1) HOT SURFACE: Risk of burn

- Keep off from touching surface of the pump as it is heated.
- Keep off from touching upper side surface of the controller while the pump is in deceleration as it is heated.



(2) Do not remove cover, or else it may cause some changes inside and it is failed.



(3) Be sure to use specified cable for this controller. If not, it may cause connector be broken and controller itself failed.



(4) Do not shut off ventilation, or else the inside of controller get heated and it is failed.



(5) SECURITY Seal

This label certifies that the product was made or maintained by ULVAC KIKO or by ULVAC KIKO authorized facility.

In case "this label is removed" or "there is mark showing once this label has been removed", ULVAC KIKO warranty shall not be applied to the product

○ Location of Label

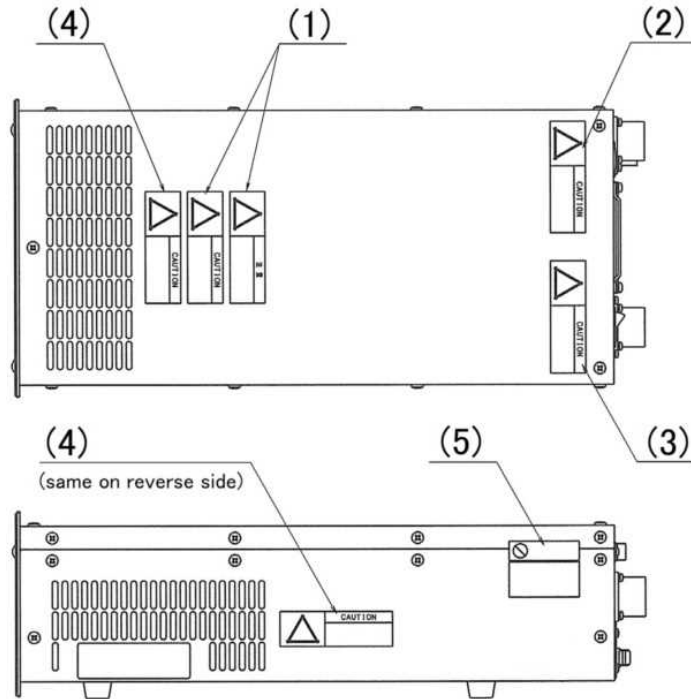

○ Installation Precautions

Do not apply abnormal loads to the turbo molecular pump control cable plug and/or connector. Abnormal loads may cause cable disconnection.

(1) Do not pull the turbo molecular pump control cable by the connector or plug.



(2) When installing the controller into equipment, do not allow any electrical cables to be in tension or to have very tight bending radii.

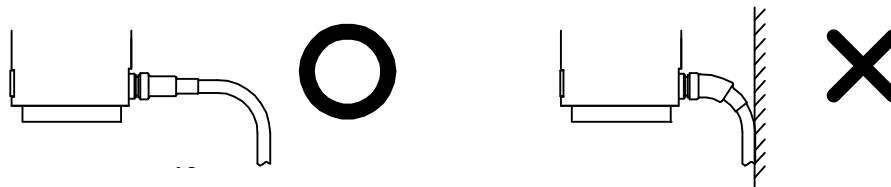

(3) Do not bundle the turbo molecular pump control cable with any cables.

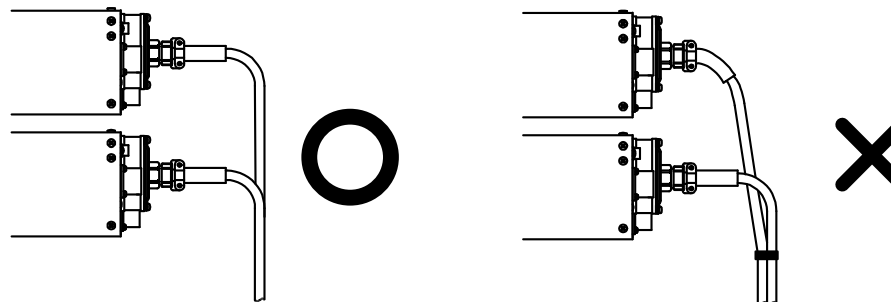

(4) Unbend the turbo molecular pump cable not to make any kink during connection.



○ Part Replacement

The lifetime of parts are specified as below.

The request for changing parts exceeding the estimated lifetime should be made to ULVAC KIKO or an approved service company in order for safety and adequate performance of the pump and controller.

Table 1 Estimated Part Life

Part list	Estimated part life
Transformer	10 years
Electrolytic capacitor	5 years
Cooling fan	5 years
Button-type battery	10 years

No Text

Table of contents

Introduction

Copyrights and Disclaimers	i
Precautions for Safe Operation	ii
○Operating Precautions	iii
○Explanation of Label	iv
○Location of Label	v
○Installation Precautions	vi
○Part Replacement	vii
Table of contents	ix

Section 1 OUTLINE AND DESCRIPTIONS

1.1 Outline	2
1.2 Descriptions	3
1.2.1 Controller	3
1.2.2 Control Cable	4
1.2.3 Motor Cable	4
1.2.4 Standard Accessories	4

Section 2 IDENTIFICATION AND FUNCTION

2.1 Controller	6
----------------	---

Section 3 CONSTRUCTION AND PRINCIPLE

3.1 Controller	10
----------------	----

Section 4 SPECIFICATIONS

4.1 Controller.....12

Section 5 INSTALLATION

5.1 Installation of the Controller.....16
5.1.1 Location of the Controller.....16
5.1.2 Installation of the Controller.....16
5.2 Connection of Power Cable.....19
5.3 Connection of the Pump to the Controller.....21

Section 6 OPERATION

6.1 Outline.....24
6.1.1 Introduction.....24
6.1.2 Operation Flowchart.....25
6.2 Start-up Preparation.....31
6.2.1 Start-up Preparation Sequence in LOCAL Mode.....31
6.2.2 Start-up Preparation Sequence in REMOTE Mode.....31
6.3 Start-up.....32
6.3.1 Start-up Sequence in LOCAL Mode.....32
6.3.2 Start-up Sequence in REMOTE Mode.....32
6.4 Shutting Down.....33
6.4.1 Preparations Prior to Shutting Down Operation.....33
6.4.2 Shutting Down Sequence in LOCAL Mode.....34
6.4.3 Shutting Down Sequence in REMOTE Mode.....34
6.5 Variable Speed Operation.....35
6.5.1 Outline.....35
6.5.2 Operation from Start-up to Low Speed Rotation.....36
6.5.2.1 LOCAL Operation.....36
6.5.2.2 REMOTE Operation.....36
6.5.3 Operation from Rated Speed Rotation to Low Speed Rotation.....37
6.5.3.1 LOCAL Operation.....37
6.5.3.2 REMOTE Operation.....37
6.5.4 Operation from Rated Speed Rotation to Low Speed Rotation.....38
6.5.4.1 LOCAL Operation.....38
6.5.4.2 REMOTE Operation.....38
6.6 Software Operation.....39
6.7 Remote-control Connector.....54
6.7.1 Specifications.....54

Section 7 TROUBLESHOOTING

7.1	Nothing Happens After an Operation is Made	58
7.2	Power Failures	59
7.2.1	Power Failure Counter-operation	60
7.3	Vacuum Pressure Rise	61
7.4	Abnormal Noise and/or Vibration	61
7.5	Alarm Detection Capabilities	62
7.5.1	Movement in Alarm Detection Capabilities (ALARM)	62
7.5.2	Movement in Alarm Detection Capabilities (WARNING)	62
7.5.3	Reset Procedure	63

Appendix A COMMUNICATIONS

- A1 GENERAL SPECIFICATION·····A-2
- A2 INTERFACE SPECIFICATION·····A-3
 - A2.1 RS-232C·····A-3
 - A2.1.1 Transmission Specification·····A-3
 - A2.1.2 Communications Connector·····A-3
 - A2.1.3 CABLE·····A-3
 - A2.2 RS-485·····A-5
 - A2.2.1 Transmission Specification·····A-5
 - A2.2.2 Communications Connector·····A-5
 - A2.2.3 CABLE·····A-5
- A3 CONTROLLER TO COMPUTER CONNECTION·····A-8
 - A3.1 Communication Cable Connection·····A-8
 - A3.2 Serial Communications Baud Rate Configuration·····A-8
 - A3.3 RS-485 Multi-drop Settings·····A-8
- A4 SERIAL COMMUNICATIONS PROTOCOL·····A-9
- A5 TABLE OF COMMANDS·····A-11
- A6 COMMAND DESCRIPTION·····A-16
 - A6.1 Operation Mode·····A-16
 - A6.2 Operation·····A-17
 - A6.3 Run Status·····A-18
 - A6.4 Parameters·····A-19
 - A6.5 Events·····A-19
 - A6.6 Timer·····A-20
 - A6.7 History·····A-20
 - A6.8 Settings·····A-21
 - A6.9 Shared Answer·····A-21
- A7 RS-232C COMMANDS / ANSWERS(SEND AND RECEIVE Examples)A-22
- A8 RELATION OF LOCAL MODE TO REMOTE MODEOPERATIONS··A-25
- A9 TROUBLESHOOTING·····A-26
 - A9.1 No Message can Transmit and Receive·····A-26
 - A9.2 Sending and Receiving are Done,
But Receivable Messages are Invalid·····A-26
 - A9.3 Characters Get Disordered from Time
to Time, Then Resulting in CHECKSUM Error·····A-26

OUTLINE AND DESCRIPTIONS



- 1.1 Outline
- 1.2 Descriptions
 - 1.2.1 Controller
 - 1.2.2 Control Cable
 - 1.2.3 Motor Cable
 - 1.2.4 Standard Accessories

1.1 Outline

The turbo molecular pump is a vacuum pump. The turbo molecular pump is used with a backing vacuum pump to create a high vacuum in a vacuum chamber.

Typical Applications; Semiconductor equipments,
Industrial equipments,
R&D applications,
The other ultra high vacuum applications.

The turbo molecular pump (one standard set) consists of the following items.

- Pump Unit 1 pc
- Controller 1 pc
- Control Cable 1 pc
- Motor Cable 1 pc
- Standard Accessories 1 Set

The cable length must be specified for the control cable and motor cable (Refer to Section 1.2.2 and Section 1.2.3).

1.2 Descriptions

1.2.1 Controller

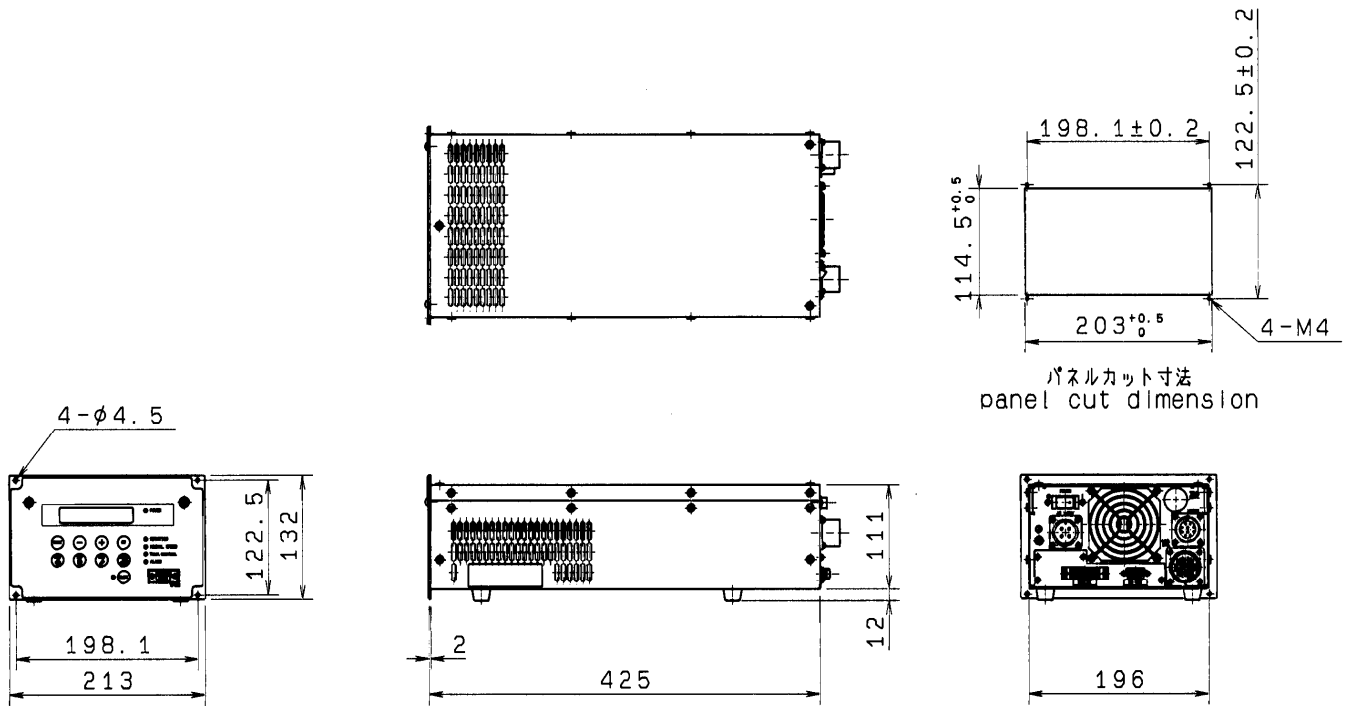

Fig. 1-1 Outside Dimensions

1.2.2 Control Cable

The cable can be selected from the following.

Description	Note
Control cable	3 meters length, straight plugs for both sides. 5 meters length, straight plugs for both sides. 7 meters length, straight plugs for both sides. 10 meters length, straight plugs for both sides.

1.2.3 Motor Cable

The cable can be selected from the following.

Description	Note
Motor cable	3 meters length, straight plugs for both sides. 5 meters length, straight plugs for both sides. 7 meters length, straight plugs for both sides. 10 meters length, straight plugs for both sides.

1.2.4 Standard Accessories

	Description	Q'ty	Notes
1	Power cable	1	5 meters length
2	Remote-control connector	1	MR-34MG (Pin type connector) MR-34L4 (Connector hood)
3	Instruction manual	1	

IDENTIFICATION AND FUNCTION



2.1 Controller

2.1 Controller

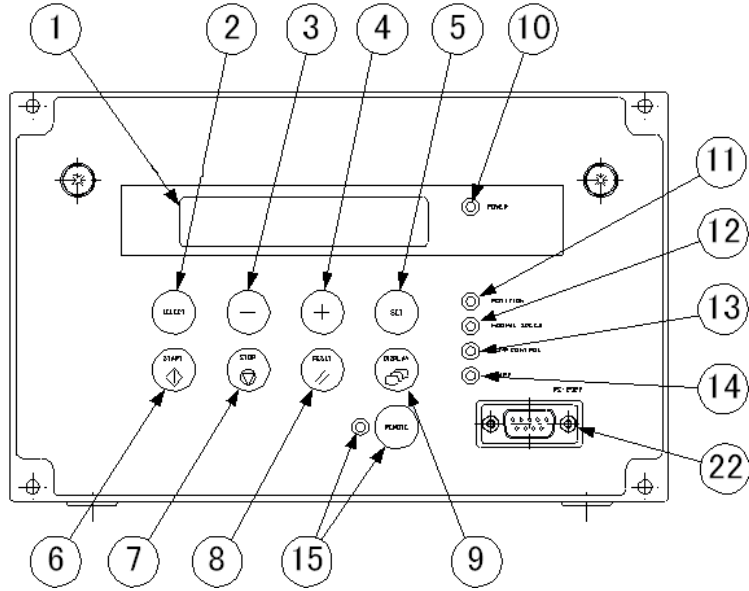

Fig. 2-1 Front Control Panel

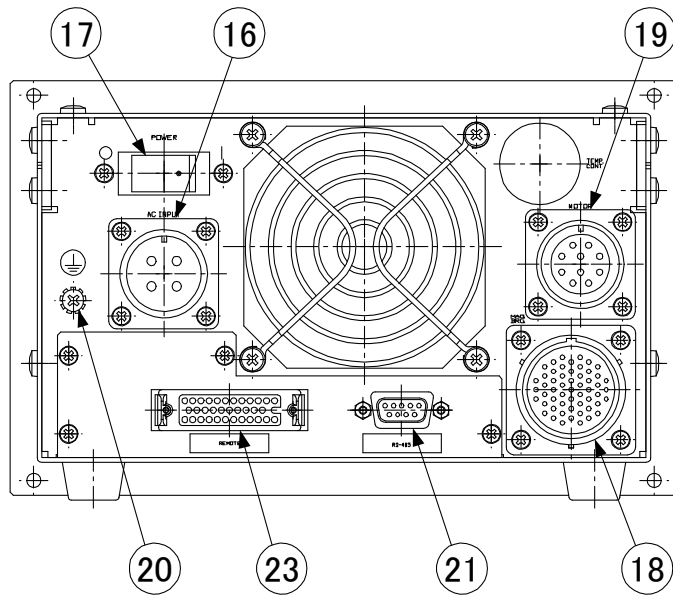

Fig. 2-2 Rear Panel

- (1) LCD.....Display operation monitor, alarm contents, settings
(Refer to Section 6.6 "Software Operation").
- (2) SELECT KEY.....LCD display operation key, select menu.
- (3) - KEY.....LCD display operation key, previous menu or subtraction.
- (4) + KEY.....LCD display operation key, next menu or addition.
- (5) SET KEY.....LCD display operation key, set menu.
- (6) START SWITCH.....Push to start rotation of the pump's rotor.
- (7) STOP SWITCH.....Push to apply the brake to stop rotation of the pump's rotor.
- (8) RESET SWITCH.....Push to stop the buzzer after an alarm or warning occurs. After remedying the cause of the alarm, push the RESET switch again to turn off the ALARM lamp. However, the buzzer sounds again if the RESET switch is pushed again before the cause of the alarm is remedied.
- (9) DISPLAY SWITCH.....LCD display operation key, change display mode.
- (10) POWER LAMP.....Power ON indicator lamp (green).
- (11) ROTATION LAMP.....Operation indicator lamp indicating that the pump's rotor is running (green).
- (12) NORMAL SPEED LAMP.....Operation indicator lamp indicating that the pump's rotor is rotating normally (green).
- (13) TEMP. CONTROL LAMP.....This lamp is always turned off in EI-R04M.
- (14) ALARM LAMP.....Alarm/warning lamp (yellow).
Refer to Section 7.5 "Alarm Detection Capabilities".
Lights when an alarm occurs or flashes to give a warning.
- (15) REMOTE SWITCH/LAMP.....When the REMOTE switch is pushed, the REMOTE lamp turns on or off.
When the lamp ON, the signal from the REMOTE CONNECTOR and the command from the serial interface are available. When the lamp OFF, START and STOP switch on the front panel are available.
- (16) AC INPUT CONNECTOR.....Power cable receptacle.
- (17) POWER SWITCH.....Power switch.
- (18) MAG.BRG. CONNECTOR.....Control cable receptacle.
- (19) MOTOR CONNECTOR.....Motor cable receptacle.
- (20) EARTH GROUND.....Electrical grounding terminal.
- (21) RS-485 CONNECTOR.....Serial interface connector (Note 1).
- (22) RS-232C CONNECTOR.....Serial interface connector (Note 1).
- (23) REMOTE CONNECTOR.....Remote-control connector.

(Note 1) Refer to APPENDIX-A "COMMUNICATIONS" for details.

No Text

CONSTRUCTION AND PRINCIPLE



3.1 Controller

3.1 Controller

The controller is composed of the magnetic bearing control system and the high frequency motor system and does not use back up batteries for electrical power failure.

The magnetic bearing control system controls the levitation of the rotor inside the turbo molecular pump. The system detects the rotor position by an electrical signal received from the gap sensors and maintains the levitation by regulating the current to the magnetic bearings.

The high frequency motor system rotates the rotor at a rated rotational speed. This frequency power system converts AC/single phase commercial power to controlled DC/three phase pulsed power. The DC/three phase pulsed power drives the DC motor that is an integral part of the rotor. If the electrical power is interrupted while the rotor is in a high-speed rotation, then the motor becomes a generator to power the magnetic bearing system during a power failure deceleration mode; therefore, the need for a battery backup system is eliminated.

The controller is equipped with an RS-232C and an RS-485 serial interface and with Contact input/output to operate the turbo molecular pump from an external source. The operational status can be monitored and the history retrieved through the RS-232C and RS-485. Refer to APPENDIX-A "COMMUNICATIONS" for instructions to remotely operate the turbo molecular pump using the RS-232C and RS-485 serial interface.

The controller, control cable, motor cable and the pump unit are all mutually compatible.

SPECIFICATIONS



4.1 Controller

4.1 Controller

Controller model		EI-R04M (UTM)
Suitable pump		UTM800A-MS、UTM1000A-MS、UTM1300A-MS、UTM1500A-MS
Exchangeable compatibility		Control cable, Motor cable, Pump main unit and Controller are interchangeable.
Magnetic bearing		5 axis control. No Battery is required (When power failure occur, magnetic bearing is support by regenerative power from motor).
Speed control		Feedback control
Speed variation		Speed is variable between 25 % and 100 % of the rated speed (set as 0.1 %).
Display	LCD	20 characters×2 lines (With LED back light)
	LED	POWER / ROTATION / NORMAL / SPEED / ALARM / REMOTE / TEMP.CONTROL (not in use)
Communication	Contact	REMOTE (MR 34pin) Input: START / STOP / RESET / LOW SPEED Output: ROTATION / ACC. / BRAKE / NORMAL / REMOTE / ALARM / WARNING
	Serial	Front panel: RS-232C (D-sub 9 pin male, Screw lock size: M2.6) Rear panel: RS-485 (D-sub 9 pin female, Screw lock size: M2.6)
Alarm detection	Alarm	Pump temperature, Pump start-up failure, Overload, Overspin for motor, Failure of magnetic bearing, Controller malfunction (Overtemperature inside controller, Fail drive circuit), Power failure
	Warning	Failure of magnetic bearing, Controller malfunction (Overtemperature inside controller)
Protection	Alarm	ALARM LED lights, buzzer sounds, alarm description displayed on LCD. Power failure: Decelerates while maintaining magnetic levitation by regenerative breaking power. Levitation is stopped after deceleration to a fixed low speed, and the rotor is supported by the touch-down bearing. Once power is restored, restart is possible after resetting. When other alarms occur: Stops operation or decelerates. Magnetic levitation is continued.
	Warning	ALARM LED flashes, buzzer sounds, warning description displayed on LCD. Pump operation continues
Momentary power failure (Note 1)		If the electrical power is recovered in 1 second or less, then the controller operation prior to the electrical power failure is continued. No change output signal. Otherwise, the turbo molecular pump rotor is decelerated. If the power is disrupted over 1 second, the brake will engage. The pump can be restarted after the reset operation.
Alarm history		Stores the date, time and detected event information for the last 99 alarm events.
Input electric power	Voltage (Note 2)	Single phase 200 to 240 VAC (50 / 60 Hz)
	Maximum power	1.0 kVA
	Insulation withstand voltage	1500 V, 1 minute
	Short circuit current ratings(SCCR)	200A
Mass		8 kg
Environmental conditions	Temperatures	Operation: 0 to 45 degrees C. / Storage: -25 to 70 degrees C. (No dew condensation)
	Relative humidity	40~80%RH
Installation conditions(Refer to UL/EN 61010-1 standard)		Use: Indoor, Altitude max: 2000 m Overvoltage category III, Pollution degree 2 IP classification 20

(Note 1)The time can be changed to 2 seconds from 1 second.

(Note 2)Temporary voltage fluctuation range: $\pm 10\%$, Temporary frequency fluctuation range: $\pm 2\text{ Hz}$

No Text

No Text

INSTALLATION



- 5.1 Installation of the Controller
 - 5.1.1 Location of the Controller
 - 5.1.2 Installation of the Controller
- 5.2 Connection of Power Cable
- 5.3 Connection of the Pump to the Controller

5.1 Installation of the Controller

5.1.1 Location of the Controller

Install and anchor the controller inside a rack, which shall be located at a place where it is not exposed to direct sun ray and well ventilated. Avoid to locate it at the following places.

- Place where it is very humid, dusty and, in addition, oil smoke, vapor, water, etc, are exist.
- Place where the controller is exposed to direct sun ray and abnormally high temperature.
- Place with high amplitude of vibration and impact.
- Near chemically active gas and explosive/combustible gas.
- Place with strong magnetic field and electric field, noisy place, and place with strong radioactive ray.
- Unventilatable place.

5.1.2 Installation of the Controller

When mounting the controller onto the customer's rack, use the front panel installation holes. The installation panel and screws are to be supplied by the customer.

Prepare the shelf to support the weight of the controller in the rack.

How to install the unit onto a rack

- (1) Turn the controller over and remove the four rubber pads.
- (2) Pass the controller through the cutout hole in the installation panel and secure it with four screws (Refer to Fig. 5-2).
- (3) In order to ensure that the interior of the controller is cooled sufficiently, leave a gap inside the rack of at least 30 mm above, 5 mm on either side, and 50 mm to the rear of the controller (Refer to Fig. 5-1).
- (4) The space required for installing the cables is shown in Fig. 5-5.
- (5) Reattach the rubber pads if necessary.

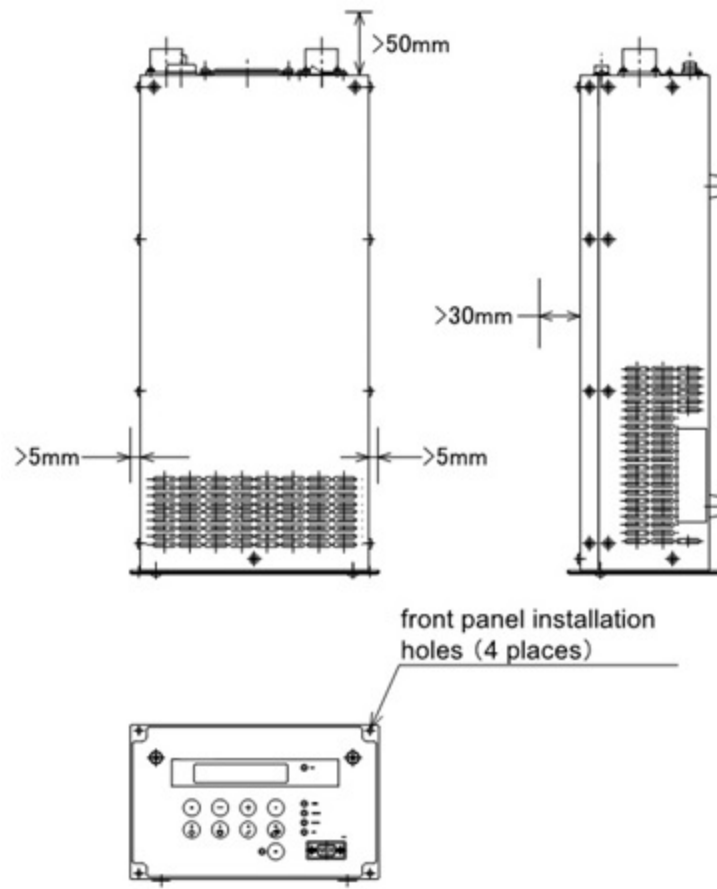

Fig. 5-1 Leave Enough Space Around the controller

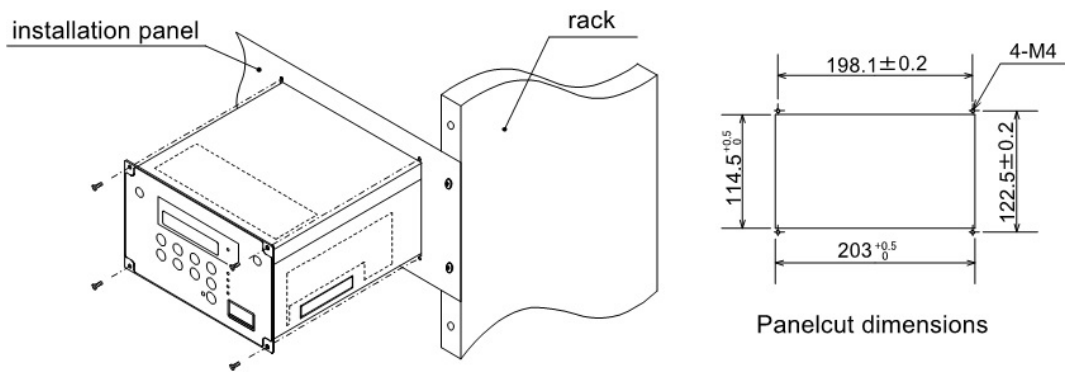

Fig. 5-2 Mount the controller

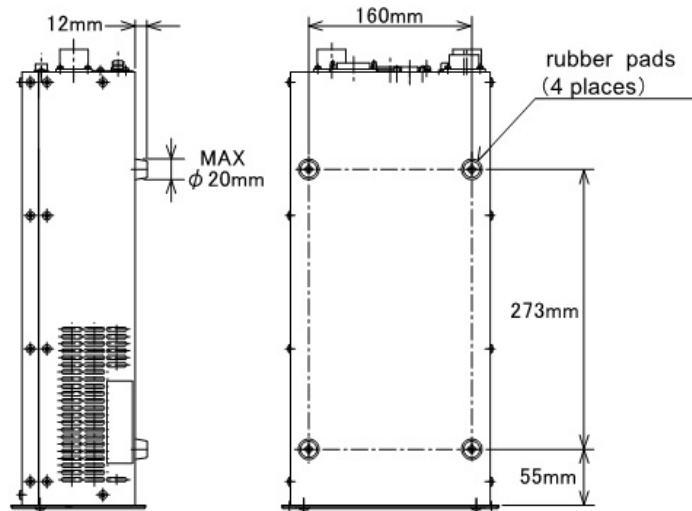
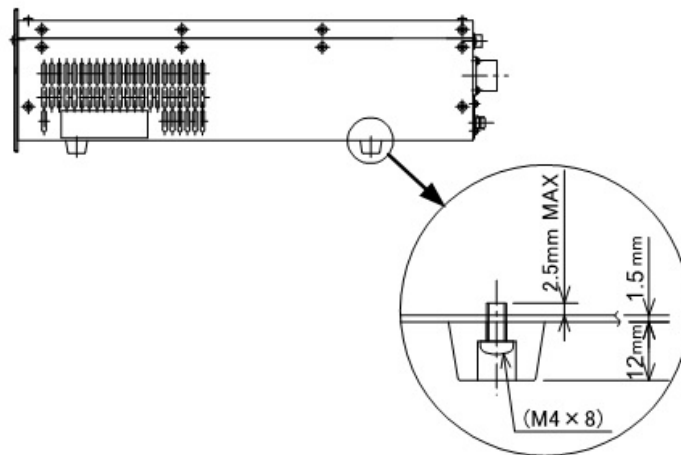

Fig. 5-3 Location of Rubber Pads



(Note 1) Use the prescribed screws to attach the rubber pads. Using the wrong screws can lead to damage or failure of the controller.

Fig. 5-4 Attaching the Rubber Pads

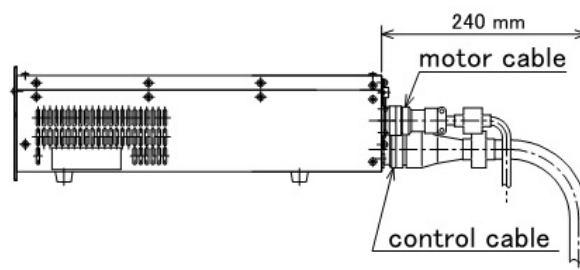

Fig. 5-5 Space to Connect the Cable

5.2 Connection of Power Cable

CAUTION

The standard power input voltage of the controller is 200 to 240 VAC. Connect the controller to the voltage indicated on the side panel label only. Connection of the controller to the incorrect input voltage can cause damage to the equipment. Controller via a circuit breaker (rating 15 A). Please provide PE (Protective Earth) connection to the terminal of a "PE" marked wire in final application. When power cable whose length is longer than 5 m is used to input AC power, protective earth line has to be connected to the PROTECTIVE EARTH TERMINAL (Fig. 2-2 (20)) which is on rear panel of the controller with the cable which has shorter than 5 m and thicker than AWG14.

CAUTION

Electrical energy isolation (Lockout / Tagout) should be achieved by opening the main disconnect device or circuit breaker of host equipment, thereby removing power from this product. The main disconnect device or circuit breaker of host equipment should be suitably located and easily reached, and it should be marked as the disconnecting device for the equipment.

Check that the part number stuck on the cable is same as the part number shown in the power cable of Section 1.2.4 "Standard Accessories".

Connection of Power Cable:

- (1) Connect the power cable terminal to the terminal board of user's power distribution board for equipment. The wire with [PE] mark is for earth use and other remaining two wires are for single phase AC power (Refer to Fig. 5-7, Table 5-1).
First, connect the wire [PE] mark. Next connect the other two wires.
- (2) Turn off the POWER switch (Fig. 2-2 (17)) on the rear panel of the controller. Or otherwise be sure to check that it is in off.
- (3) Connect the power cable connectors to the controller AC INPUT connector (Fig. 2-2 (16))

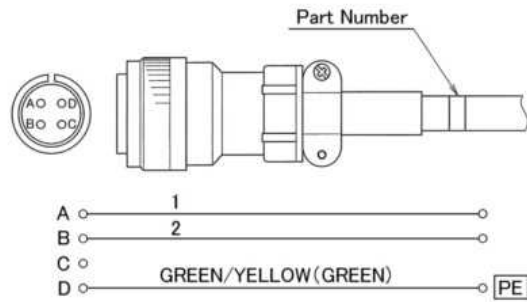

Fig. 5-6 Power Cable (Connector)

REFERENCE

For the specified power voltage, refer to the side panel of the controller.

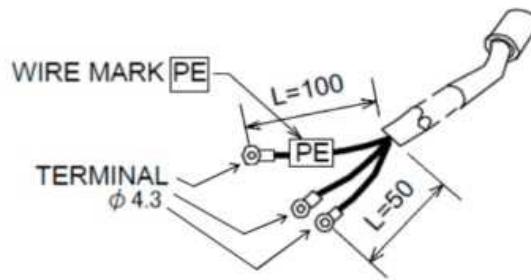

Fig. 5-7 Power Cable

Table 5-1 Power Cable CONNECTION

Wire color of power cable		Green/Yellow	Black	White
Location	EU	PE	N	L
	US	GND	L2	L1

5.3 Connection of the Pump to the Controller

NOTICE

Insert straight the control cable connector after checking its key direction. Inserting it in oblique direction would cause damage of the connector pins. After the insertion, turn the cable connector clockwise until the rotation lock clicks.

NOTICE

Don't disconnect each cable while the pump is running. Particularly before disconnecting the control cable, check complete shutdown of the pump by ROTATION lamp goes out and, thereafter, turn off the POWER switch.

Control Cable:

Use the control cable that conformed CE marking. It has ferrite core at controller side. Control cables which are identified available for the use. But, If no ferrite core is fixed around a control cable, it is not conformed CE marking.

Connecting Sequence (Refer to Fig. 2-2, Fig. 5-8):

- (1) Turn off the POWER switch (Fig. 2-2 (17)) on the rear panel of the controller. Or otherwise check that it is off.
- (2) Connect the controller to the MAG.BRG. connector (Fig. 2-2 (18)) and MOTOR connector (Fig. 2-2 (19)) of the pump proper with the control cable.
- (3) For remote operation of the turbo molecular pump or intake of status signal, etc., connect the RS-485 connector (Fig. 2-2 (21)) or RS-232C connector (Fig. 2-1 (22)), Remote-control connector (Fig. 2-2 (23)). When using Remote-control connector, make wiring connection as instructed in Section 6.7 "Remote-control Connector".

SECTION 5 INSTALLATION

All interfaces are SELV (Safety extra-low Voltage).

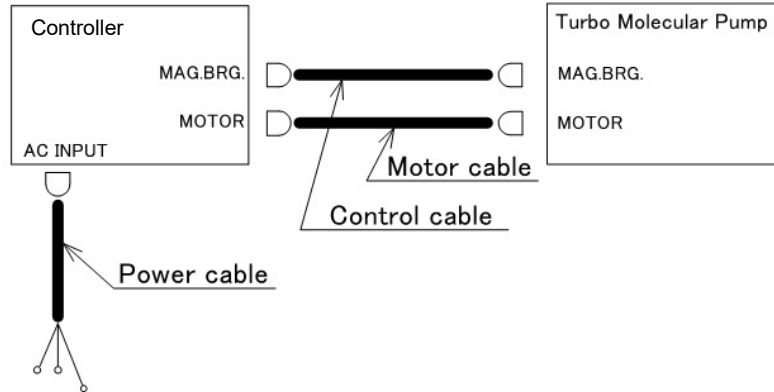

Fig. 5-8 Connection of Cables

OPERATION



- 6.1 Outline
 - 6.1.1 Introduction
 - 6.1.2 Operation Flowchart
- 6.2 Start-up Preparation
 - 6.2.1 Start-up Preparation Sequence in LOCAL Mode
 - 6.2.2 Start-up Preparation Sequence in REMOTE Mode
- 6.3 Start-up
 - 6.3.1 Start-up Sequence in LOCAL Mode
 - 6.3.2 Start-up Sequence in REMOTE Mode
- 6.4 Shutting Down
 - 6.4.1 Preparations Prior to Shutting Down Operation
 - 6.4.2 Shutting Down Sequence in LOCAL Mode
 - 6.4.3 Shutting Down Sequence in REMOTE Mode
- 6.5 Variable Speed Operation
 - 6.5.1 Outline
 - 6.5.2 Operation from Start-up to Low Speed Rotation
 - 6.5.3 Operation from Rated Speed Rotation to Low Speed Rotation
 - 6.5.4 Operation from Low Speed Rotation to Rated Speed Rotation
- 6.6 Software Operation
- 6.7 Remote-control Connector
 - 6.7.1 Specifications

6.1 Outline

CAUTION

Neither disconnect and reconnect each cable while the pump is running. Particularly for unplugging the control cable from the receptacle, check complete shutdown of the pump by ROTATION lamp goes out and, thereafter, turn off the POWER switch.

CAUTION

Do not turn the power off while the pump is running. The touch-down bearing may need to be replaced if the power is turned off repeatedly during operation. When the power is turned off while the pump is rotating, power from regenerative braking maintains the magnetic levitation until the rotational speed drops. Levitation then stops and the touch-down bearing supports the rotor. Consequently, repeated touch-down operations can reduce the life of the bearing.

6.1.1 Introduction

(Refer to Fig. 2-1 and Fig. 2-2)

The LCD (Fig. 2-1 (1)) displays "EI-R04M" when the controller POWER switch (Fig. 2-2 (17)) is turned on.

It then displays "SELF CHECKING" and the controller conducts self-diagnosis. If the result is good, the LCD changes into monitor mode (Refer to Section 6.6 "Software Operation" (1)), and the controller is operatable. But if an alarm is detected, the LCD changes into alarm mode (Refer to Section 6.6 "Software Operation" (2)), and displays detected alarm.

6.1.2 Operation Flowchart

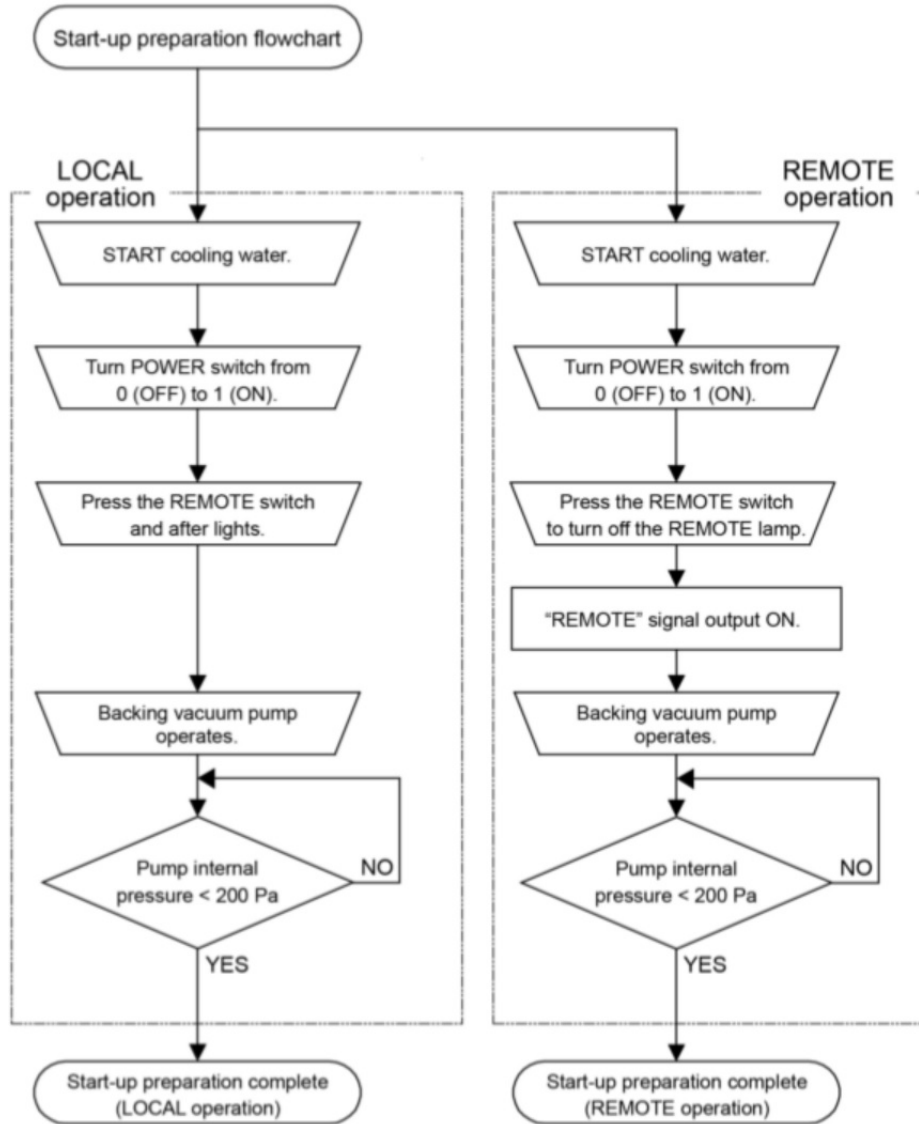

Fig. 6-1 Start-up Preparation Flowchart

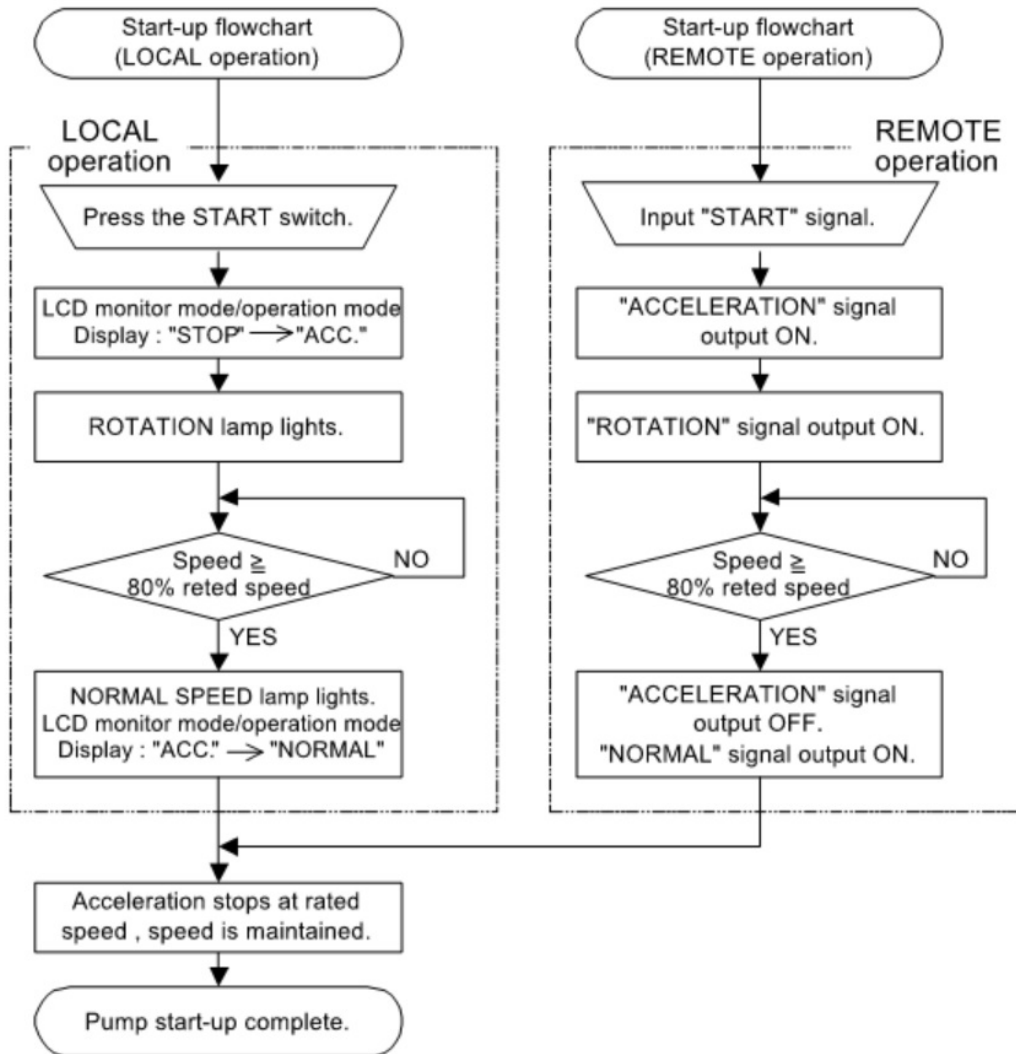

Fig. 6-2 Start-up Flowchart

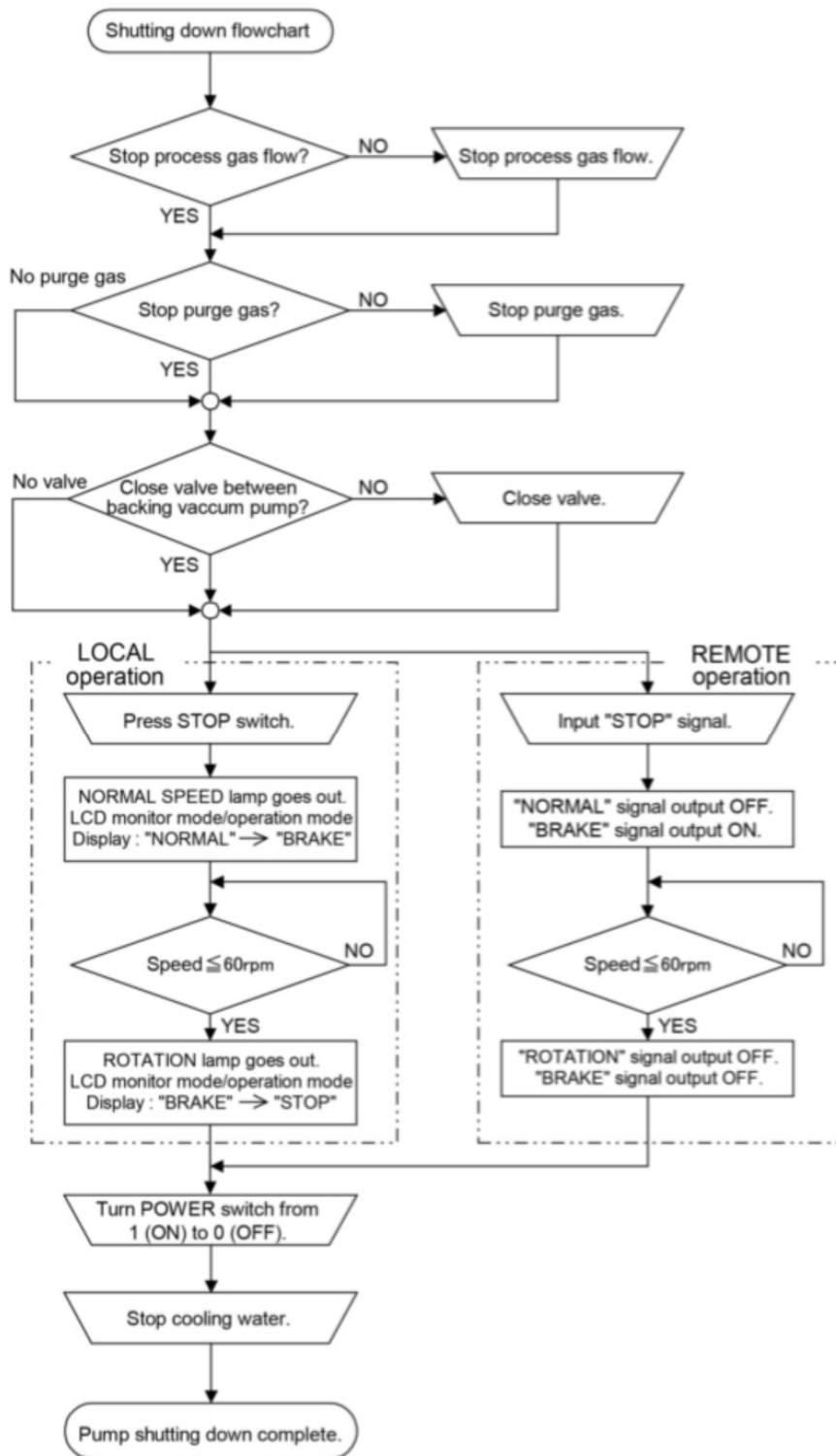
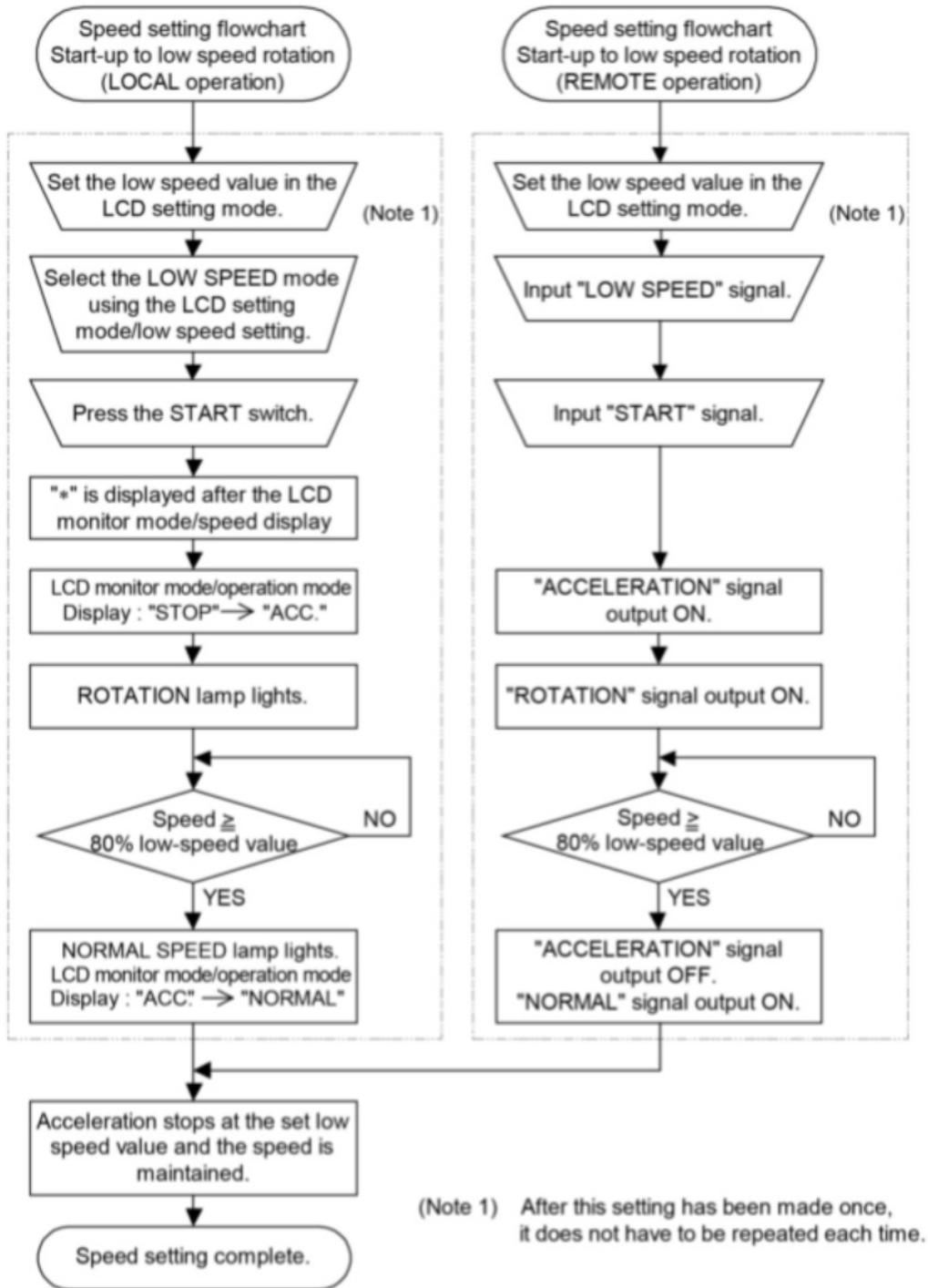
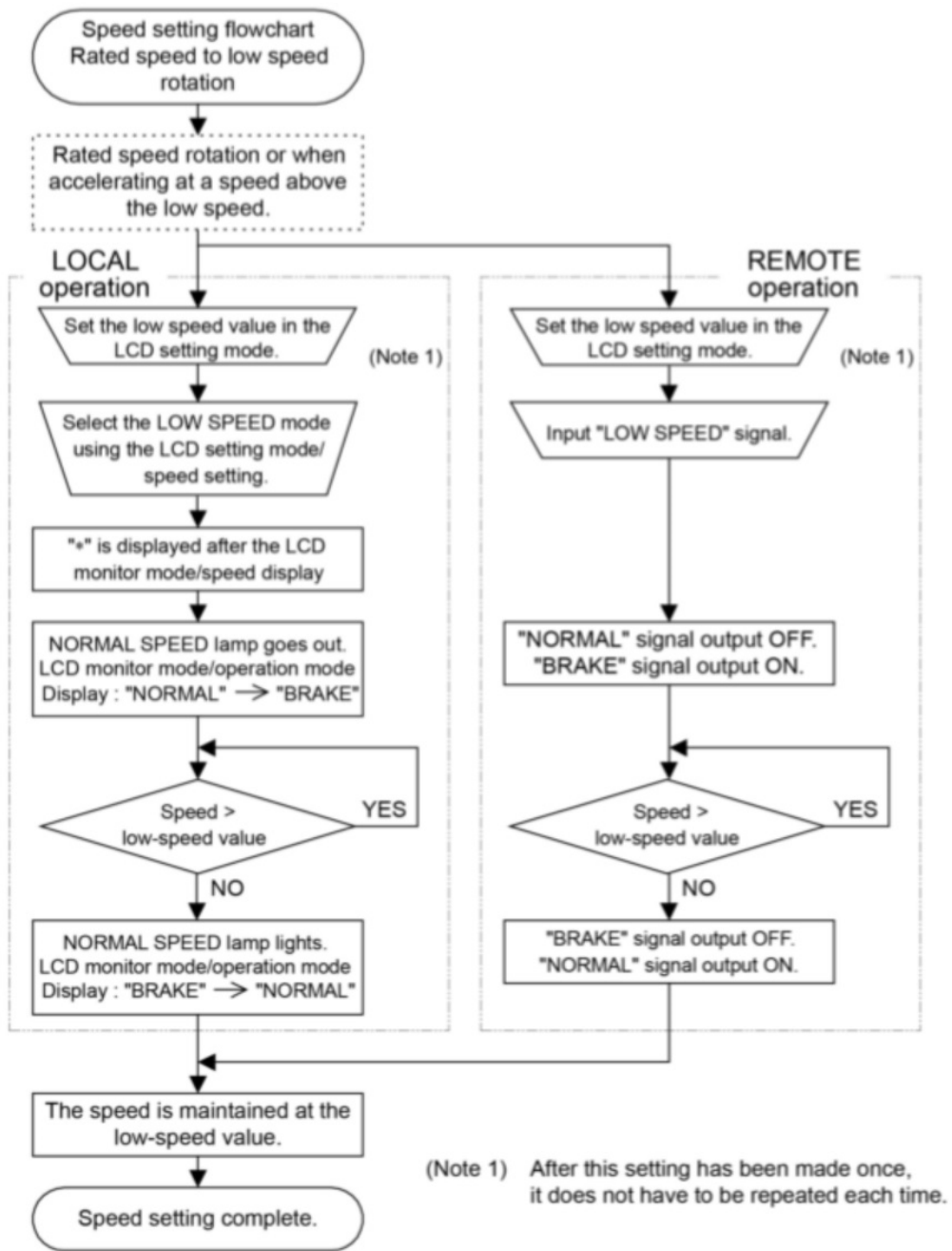

Fig. 6-3 Shutting Down Flowchart



Start-up to Low Speed Rotation
Fig. 6-4 Speed Setting Flowchart



Rated Speed to Low Speed Rotation

Fig. 6-5 Speed Setting Flowchart

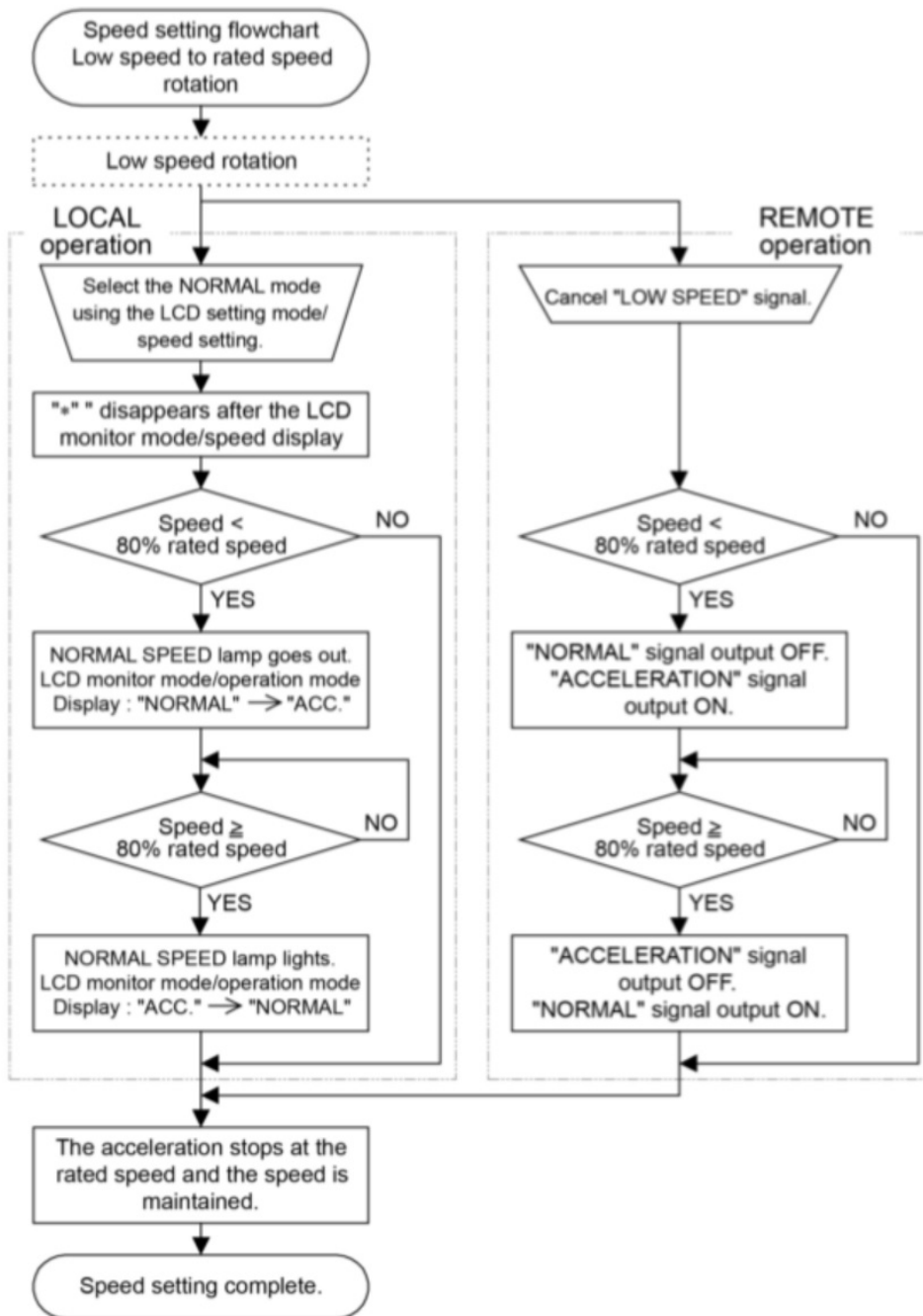

Low Speed to Rated Speed Rotation

Fig. 6-6 Speed Setting Flowchart

6.2 Start-up Preparation

(Refer to Fig. 6-1)

Push the REMOTE switch (Fig. 2-1 (15)) to either LOCAL or REMOTE mode. REMOTE lamp OFF in LOCAL mode, and REMOTE lamp ON in REMOTE mode.

LOCAL (REMOTE lamp OFF)	The pump can be started/stopped by pushing START/STOP switch on the front panel of the controller.
REMOTE (REMOTE lamp ON)	he pump runs only according to input signal from the remote-control connector (Fig. 2-2 (23)) or serial interface connector (Fig. 2-2 (21), Fig. 2-1 (22)).

Refer to APPENDIX-A "COMMUNICATIONS" for serial interface connector.

6.2.1 Start-up Preparation Sequence in LOCAL Mode

- (1) Feed the cooling water into the cooling line.
- (2) Turn on the POWER switch (Fig. 2-2 (17)) of the controller and check if the POWER lamp (Fig. 2-1 (10)) lights. And the rotor of the turbo molecular pump is levitated by the magnetic bearing.
- (3) Evacuate the turbo molecular pump by using a backing vacuum pump.
- (4) Start-up preparation is complete if the pressure in the turbo molecular pump reduces below 200 Pa.

6.2.2 Start-up Preparation Sequence in REMOTE Mode

- (1) Feed the cooling water into the cooling line.
- (2) Turn on the POWER switch (Fig. 2-2 (17)) of the controller and check that "REMOTE" signal (Refer to Table 6-3) from the remote-control connector (Fig. 2-2 (23)) is ON. Under this condition, the rotor of the turbo molecular pump is levitated by the magnetic bearing.
- (3) Evacuate the turbo molecular pump by using a backing vacuum pump.
- (4) Start-up preparation is complete if the pressure in the turbo molecular pump reduces below 200 Pa.

NOTICE

When turning the POWER switch for the controller on or off, a "clunk" sound may be heard from inside the pump. This sound is from the rotor inside the pump being levitated or delevitated. This is normal.

6.3 Start-up

(Refer to Fig. 6-2)

6.3.1 Start-up Sequence in LOCAL Mode

- (1) Start-up begins when the Section 6.2.1 "Start-up Preparation Sequence in LOCAL Mode" is complete.
- (2) Push the START switch (Fig. 2-1 (6)).
- (3) "ACC." is displayed on the pump monitor mode / operation mode LCD and pump acceleration starts. The ROTATION lamp (Fig. 2-1 (11)) lights.
- (4) When the rotational speed reaches 80% rated value, the NORMAL SPEED lamp (Fig. 2-1 (12)) lights and the pump monitor mode / operation mode LCD changes from "ACC." to "NORMAL". Pump start-up is complete.

6.3.2 Start-up Sequence in REMOTE Mode

- (1) Start-up begins when the Section 6.2.2 "Start-up Preparation Sequence in REMOTE Mode" is complete.
- (2) "START" signal (Refer to Table 6-3) is input from the remote-control connector (Fig. 2-2 (23)).
- (3) The pump acceleration starts when the remote-control connector "ACCELERATION" signal (Refer to Table 6-3) turns on. The "ROTATION" signal (Refer to Table 6-3) turns on.
- (4) When the rotational speed reaches 80 % rated value, the remote-control connector "ACCELERATION" signal (Refer to Table 6-3) turns off and the "NORMAL" signal (Refer to Table 6-3) turns on. Pump start-up is complete.

6.4 Shutting Down

CAUTION

After having operated the turbo molecular pump for evacuation of corrosive gas, keep the pump internal as vacuumed even after shutdown. Inflow of water content in the air to the pump internal would cause rapid corrosion trouble of the pump internals. The pump corrosion may result in damaging the vacuum vessel interior and other units, causing pressure fluctuation by stopping the pump and dispersal of parts.

CAUTION

When increasing internal pressure of the turbo molecular pump up to around the atmospheric pressure by use of inert gas, etc., adjust the pressure reducing valve so that the internal pressure of the same pump does not exceed 20 kPa [GAUGE].

CAUTION

Electrical energy isolation (Lockout / Tagout) should be achieved by opening the main disconnect device or circuit breaker of host equipment, thereby removing power from this product. The main disconnect device or circuit breaker of host equipment should be suitably located and easily reached, and it should be marked as the disconnecting device for the equipment.

For shut-down of the turbo molecular pump, follow the sequence below (Refer to Fig. 6-3).

6.4.1 Preparations Prior to Shutting Down Operation

- (1) Check that process gas inflow is in complete stop. When main valve is installed between the turbo molecular pump and vacuum chamber, close the valve.
- (2) When purge gas is being supplied into the turbo molecular pump, stop the gas flow.
- (3) When forevacuum valve is installed between the turbo molecular pump and backing vacuum pump, close the valve.

6.4.2 Shutting Down Sequence in LOCAL Mode

- (1) Push the STOP switch (Fig. 2-1 (7)) and check that the indication on the pump monitor mode / operation mode LCD switches from "NORMAL" to "BRAKE".
Then the NORMAL SPEED lamp (Fig. 2-1 (12)) goes off.
- (2) Wait until the ROTATION lamp (Fig. 2-1 (11)) goes out. The pump monitor mode / operation mode LCD switches from "BRAKE" to "STOP".
- (3) Turn off the controller POWER switch (Fig. 2-1 (17)).
- (4) Stop the cooling water flow.
- (5) If you want to isolate this product from electrical supply, unplug AC INPUT connector.

6.4.3 Shutting Down Sequence in REMOTE Mode

- (1) Input the "STOP" signal (Refer to Table 6-3) from the remote-control connector (Fig. 2-2 (23)) and check that the "BRAKE" signal (Refer to Table 6-3) is ON.
- (2) Wait until the "ROTATION" signal (Refer to Table 6-3) turns off. At this time, the "BRAKE" signal (Refer to Table 6-3) also turns off.
- (3) Turn off the controller POWER switch (Fig. 2-2 (17)).
- (4) Stop the cooling water flow.
- (5) If you want to isolate this product from electrical supply, unplug AC INPUT connector.

When the turbo molecular pump is turned off after pumping a corrosive gas, maintain a vacuum inside the turbo molecular pump or purge the interior of the pump with an inert gas.

Further, in such a case when a hydraulic rotary vacuum pump is used as backing vacuum pump and there is possible reverse flow and diffusion of oil from the backing vacuum pump, return the pump internal pressure to atmospheric pressure using dry nitrogen gas, after complete shut-down of the pump [ROTATION lamp (Fig. 2-1 (11)) goes out], to prevent the turbo molecular pump from being contaminated with oil vapor.

For shutting down the turbo molecular pump in running at high speed with infeed of dry nitrogen gas to the pump, keep the nitrogen gas flow rate at 1500 mL/min maximum.

REFERENCE

The ROTATION lamp (Fig. 2-1 (11)) goes out or "ROTATION" signal (Refer to Table 6-3) turns off when the pump rotational speed is 60 rpm or less. Turning off the POWER switch (Fig. 2-2 (17)) permits the pump rotor to be supported by the touch-down bearings.

6.5 Variable Speed Operation

CAUTION

When using the variable speed function to change the pump rotation rate, use a rotation rate that does not cause resonance with other devices installed at the site.

CAUTION

If controller is used in combination with an existing pump that was operated in combination with a controller not having the variable speed function, the variable speed function cannot be used.

If the controller is to be combined with an existing pump, modification and operational inspections are necessary. Please contact ULVAC KIKO for detailed information.

6.5.1 Outline

- (1) The rotational speed settings function sets the rotational speed by selecting between the NORMAL speed mode or LOW SPEED mode.
- (2) Select the NORMAL mode or LOW SPEED mode by LOCAL operation using the setting mode / rotational speed settings / speed setting set value on the LCD display or by REMOTE operation using the remote-control connector "LOW SPEED" signal input (Refer to Table 6-3).
- (3) The NORMAL mode or LOW SPEED mode selection can be made before or after start-up (Refer to the Speed Setting Flowcharts in Fig. 6-4, Fig. 6-5, and Fig. 6-6).
- (4) Set the low speed value between 25 % and 100 % of the rated speed in 0.1 % increment with the setting mode / rotational speed settings / low speed setting set value on the LCD display.
- (5) The low speed value can be set while the pump is rotating in the LOW SPEED mode. The pump then accelerates or decelerates to the new set value and maintains the set speed.
- (6) The time required for the speed to change is the same as the time for normal acceleration or deceleration.

For example, if the low speed value is set to 80 % and the LOW SPEED mode is selected during normal rotation, the time for the speed to drop to 80 % is approximately one-fifth of the time required to stop from rated speed only as a guide

6.5.2 Operation from Start-up to Low Speed Rotation

This is the procedure until low-speed rotation is achieved when the speed setting is made with the pump stopped (Refer to Fig. 6-4).

6.5.2.1 LOCAL Operation

- (1) Start-up begins when the Section 6.2.1 "Start-up Preparation Sequence in LOCAL Mode" is complete.
 - (2) Set the low speed value with the setting mode / rotational speed settings / low speed setting set value on the LCD display (Refer to Section 6.6 "Software Operation" (4)). After this setting has been made once, it does not have to be repeated each time.
 - (3) Select the LOW SPEED mode using the setting mode / rotational speed settings / low speed setting set value (Refer to Section 6.6 "Software Operation" (4)).
 - (4) Push the START switch (Fig. 2-1 (6)).
 - (5) While the speed is changing, "*" is displayed after the monitor mode / speed display (Refer to Section 6.6 "Software Operation" (1)).
 - (6) ACC is displayed on the pump monitor mode / operation mode LCD and the pump starts to accelerate. After a few seconds the ROTATION lamp (Fig. 2-1 (11)) lights.
 - (7) When the rotational speed reaches 80 % of low-speed value, the NORMAL SPEED lamp lights (Fig. 2-1 (12)) and the pump monitor mode / operation mode LCD switches from "ACC." to "NORMAL".
 - (8) When the pump speed reaches the set low speed value, acceleration stops and the pump speed is maintained.
- (Note) The same operation occurs if the LOW SPEED mode is selected after the START switch is pushed but before the pump speed reaches the set low speed value.

6.5.2.2 REMOTE Operation

- (1) Start-up begins when the Section 6.2.2 "Start-up Preparation Sequence in REMOTE Mode" is complete.
 - (2) Set the low speed value with the setting mode / rotational speed settings / low speed setting set value on the LCD display (Refer to Section 6.6 "Software Operation" (4)). After this setting has been made once, it does not have to be repeated each time.
 - (3) Input the "LOW SPEED" signal (Refer to Table 6-3) from the remote-control connector (Fig. 2-2 (23)).
 - (4) Input the "START" signal from the remote-control connector (Refer to Table 6-3).
 - (5) The pump starts to accelerate when the "ACCELERATION" signal (Refer to Table 6-3) from the remote-control connector (Fig. 2-2 (23)) turns on. After a few seconds the "ROTATION" signal turns on.
-

(6) When the rotational speed reaches 80 % of low speed value, the remote-control connector "ACCELERATION" signal turns off and the "NORMAL" signal turns on.

(7) When the pump speed reaches the set low speed value, acceleration stops and the pump speed is maintained.

(Note) The same operation occurs if the "LOW SPEED" signal is input after the "START" signal is input but before the pump speed reaches the set low speed value.

6.5.3 Operation from Rated Speed Rotation to Low Speed Rotation

This is the procedure to select low speed operation during rated speed rotation or when accelerating at a speed above the low speed (Refer to Fig. 6-5).

6.5.3.1 LOCAL Operation

(1) Set the low speed value with the setting mode / rotational speed settings / low speed setting set value on the LCD display (Refer to Section 6.6 "Software Operation" (4)). After this setting has been made once, it does not have to be repeated each time.

(2) Next, select the LOW SPEED mode using the setting mode / rotational speed settings / speed setting set value on the LCD display (Refer to Section 6.6 "Software Operation" (4)).

(3) While the speed is changing, "*" is displayed after the monitor mode / speed display (Refer to Section 6.6 "Software Operation" (1)).

(4) The pump monitor mode / operation mode LCD switches from "NORMAL" to "BRAKE" and the pump starts to decelerate. Then the NORMAL SPEED lamp (Fig. 2-1 (12)) goes off.

(5) When the rotational speed reaches the set low speed value, the NORMAL SPEED lamp lights and the pump monitor mode / operation mode LCD switches from "BRAKE" to "NORMAL".

(6) The pump stops decelerating and the pump speed is maintained.

(Note) A normal start-up and normal operation occurs if the mode is reverted to NORMAL speed before the pump speed reaches the set low speed value.

6.5.3.2 REMOTE Operation

(1) Set the low speed value with the setting mode / rotational speed settings / low speed setting set value on the LCD display (Refer to Section 6.6 "Software Operation" (4)). After this setting has been made once, it does not have to be repeated each time.

(2) Input the "LOW SPEED" signal (Refer to Table 6-3) from the remote-control connector (Fig. 2-2 (23)).

(3) The pump starts to decelerate when the remote-control connector "NORMAL" signal (Refer to Table 6-3) turns off and the "BRAKE" signal (Refer to Table 6-3) turns on.

(4) When the pump speed reaches the set low speed value, the remote-control connector "BRAKE" signal turns off and the "NORMAL" signal turns on.

(5) The pump stops decelerating and the pump speed is maintained.

(Note) A normal start-up and normal operation occurs if the "LOW SPEED" signal is cancelled before the pump speed reaches the set low speed value.

6.5.4 Operation from Low Speed Rotation to Rated Speed Rotation

This is the procedure to select normal speed operation during low speed rotation (Refer to Fig. 6-6).

6.5.4.1 LOCAL Operation

- (1) Select the NORMAL mode using the setting mode / rotational speed settings / speed setting set value on the LCD display (Refer to Section 6.6 "Software Operation" (4)).
- (2) The "*" disappears after the monitor mode / speed display (Refer to Section 6.6 "Software Operation" (1)).
- (3) If the set low speed value did not exceed 80 % rated speed, the pump monitor mode / operation mode LCD switches from "NORMAL" to "ACC." and the pump starts to accelerate. The NORMAL SPEED lamp (Fig. 2-1 (12)) goes off.
- (4) When the rotational speed reaches 80 % rated speed, the NORMAL SPEED lamp lights and the pump monitor mode / operation mode LCD switches from "ACC." to "NORMAL".
- (5) If the set low speed value exceed 80 % rated speed, the LCD display remains unchanged and the pump accelerates.
- (6) When the rated speed is reached, the pump stops accelerating and the pump speed is maintained.

6.5.4.2 REMOTE Operation

- (1) Cancel the "LOW SPEED" signal (Refer to Table 6-3) inputted in the remote-control connector (Fig. 2-2 (23)).
 - (2) If the set low speed value did not exceed 80 % rated speed, the remote-control connector "ACCELERATION" signal turns on and (Refer to Table 6-3) and the pump starts to accelerate. The "NORMAL" signal turns off.
 - (3) When the rotational speed reaches 80 % rated speed, the remote-control connector "ACCELERATION" signal turns off and the "NORMAL" signal turns on (Refer to Table 6-3).
 - (4) If the set low speed value exceed 80 % rated speed, remote-control signals remain unchanged and the pump accelerates.
 - (5) When the rated speed is reached, the pump stops accelerating and the pump speed is maintained.
-

6.6 Software Operation

The software operation functions are listed in Table 6-1.

Table 6-1 Software Operation Functions

Reference flowchart	Function	Description		
(1) Monitor mode	Operation mode User memo Operation status Motor speed Motor current Magnetic bearing displacement monitor Magnetic bearing unbalance monitor (Note 1)	Monitors pump operation status		
(2) Alarm mode	Alarm and warning display	Displays details of alarms and warnings.		
	Alarm and warning history and details	Displays the alarm and warning history		
Menu mode	(3) Timer	Run time Maintenance call time Number of power failure touch-downs Number of high-speed touch-downs Number of magnetic bearing warnings	Resets times and counters.	
		(4) Setting	User memo setting	Inputs user memo.
			RS-232C setting	Sets the communication environment.
			RS-485 setting	Sets the communication environment.
			Speed setting	Sets the pump speed display format.
	Power failure detect setting		Sets the power failure detect.	
	Remote-control signal setting		Sets the operations of the remote-control signals.	
	Warning output setting		External output setting for warnings	
	Default setting	Reverts to the default settings		
	(5) Self test	LCD contrast adjustment	Displays the LCD contrast adjustment.	
		Self diagnosis	Self diagnosis of the magnetic bearing sensor.	
		Corresponding model	Displays the corresponding model.	

(Note 1) When detected alarm below, the monitor function do not operate.

Alarm code: 46, 47(rotational speed error), 51 to 55 (excessive vibration of the magnetic bearing), 66 (magnetic bearing control error) (Refer to Table 7-6).

A flowchart of the entire LCD display is shown below.

SELECT, **-**, **+**, **SET** in the flowchart indicate keys on the front panel of controller, and other **□** indicated contents of the LCD display.

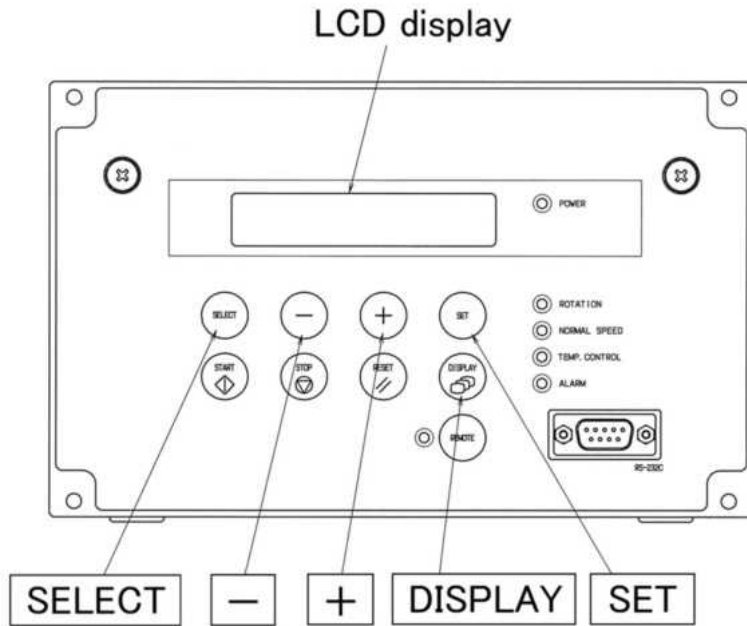
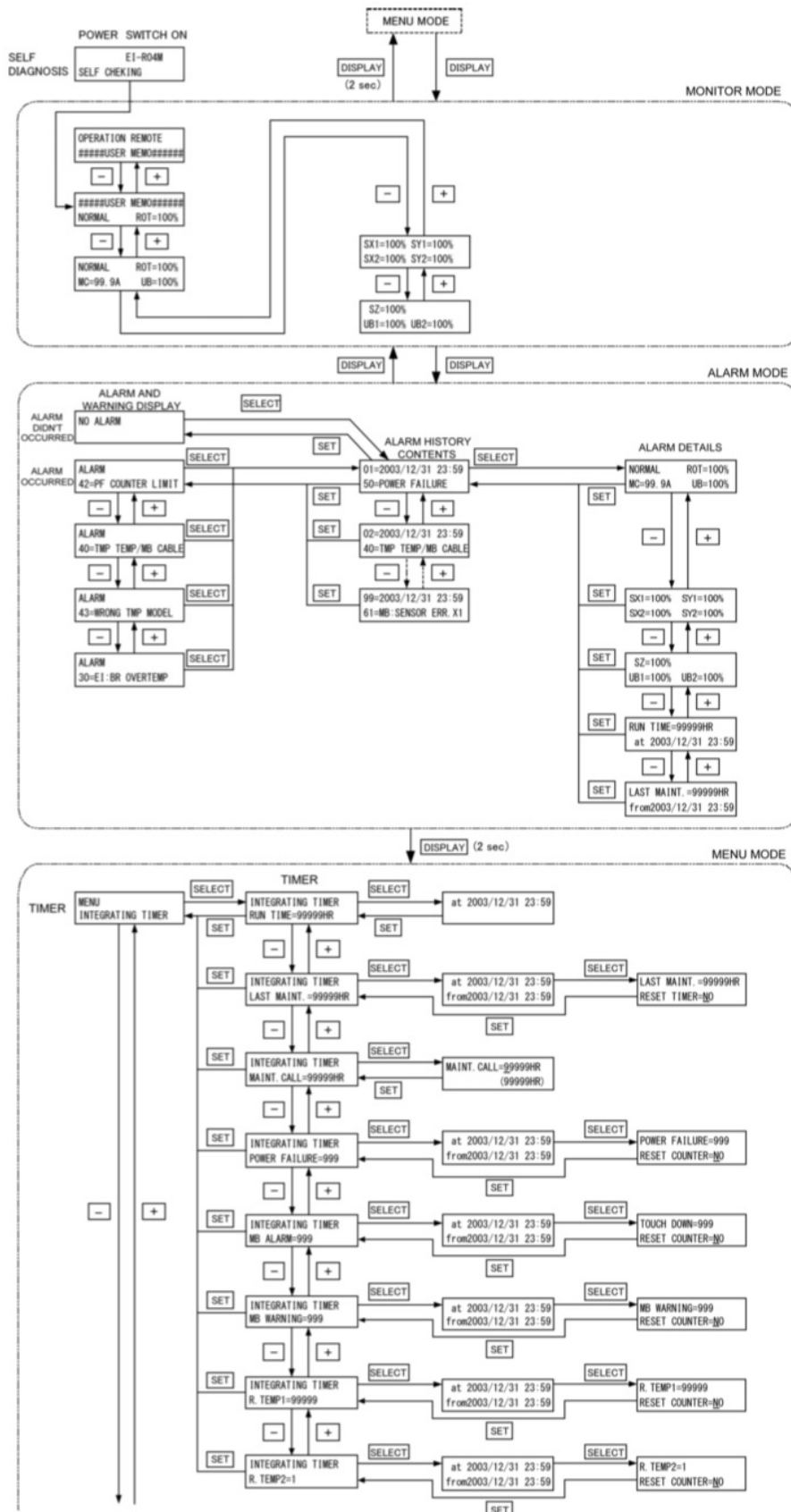

Fig. 6-7 Controller Front Panel



Detail
→ P43

Detail
→ P45

Detail
→ P46

SECTION 6 OPERATION

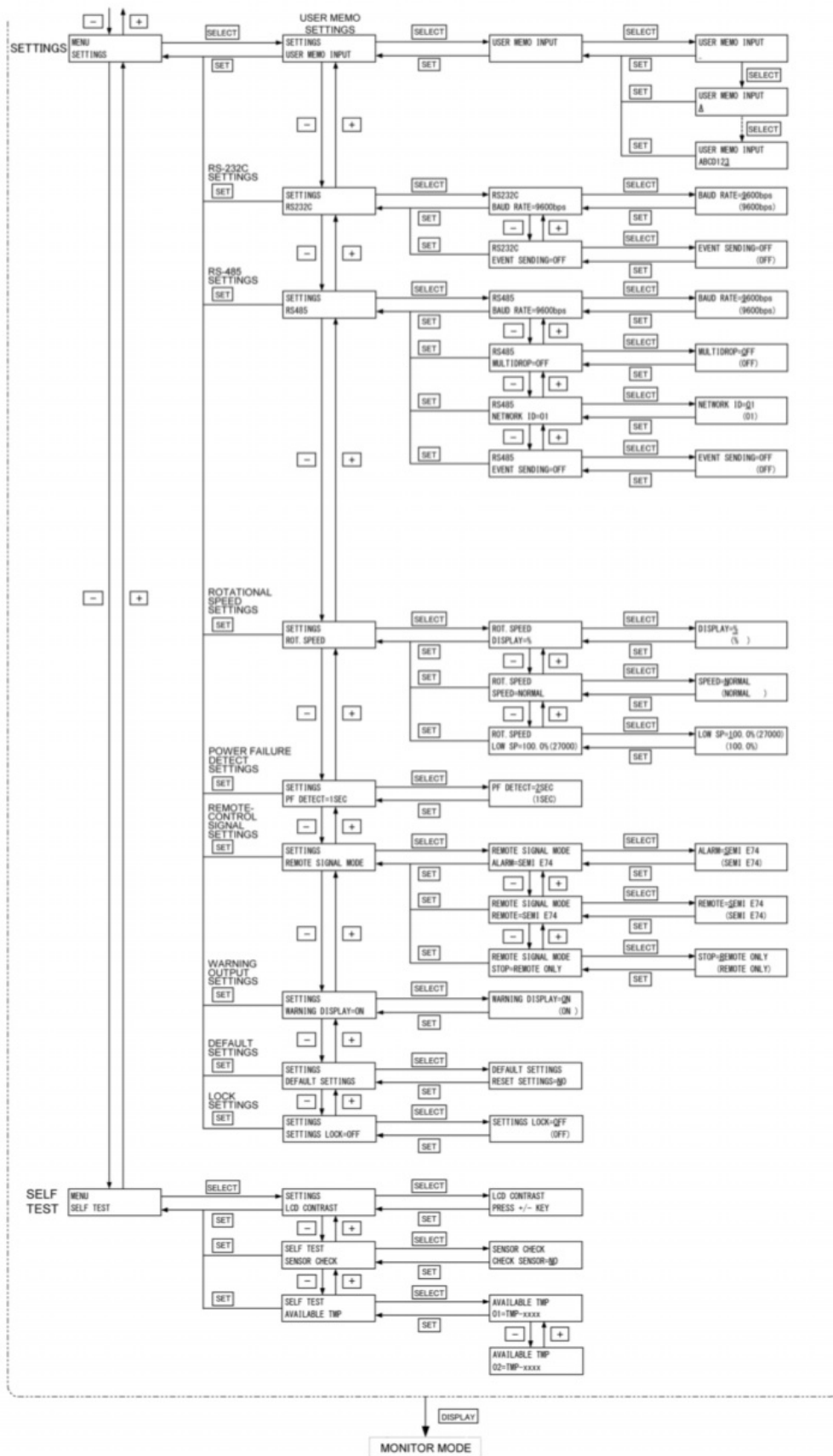

In the next tables, they are shown detailed flowchart of LCD display.

(1) MONITOR MODE

In monitor mode operation status of pump can be identified. If key **DISPLAY** is pushed in menu mode, the LCD changes into monitor mode. The LCD changes automatically into monitor mode after start or stop operation.

Mode	Operation and LCD display	Description of display
MONITOR 1		
MONITOR 2		
MONITOR 3		
MONITOR 4		
MONITOR 5		

First, Monitor 2 display following to initial display after power switch turning on.

(Note 1) Operation Mode

LCD display	Operation
LOCAL	Control by a manual switch operation on the front panel
REMOTE	Control by a remote-control signal operation
RS-232C	Control by a RS-232C communication
RS-485	Control by a RS-485 communication or optional communication.

Refer to Section 6.2 "Start-up Preparation" for details on changing the operation mode.

(Note 2) Pump Operation Mode

LCD display	Pump operation
NORMAL	Normal rotation
ACC.BRAKE	Motor acceleration
BRAKE	Motor brake deceleration
STOP	Motor stop
E-STOP	Error occurs (stop)
E-BRAKE	Error occurs (motor deceleration)
E-IDLE	Error occurs (free operation = motor stop)

(Note 3) Any character can be entered in the USER MEMO from the menu mode "SETTINGS / USER MEMO INPUT". Use it for displaying the chambers connected to the pump etc.

(Note 4) The Motor Rotational Speed display can be selected from %, rpm and rps in the menu mode "SETTINGS / ROT.SPEED / DISPLAY".

An asterisk (*) is displayed after the speed display during variable speed operation.



(2) ALARM MODE

Alarm mode is a mode to display detected alarm contents and alarm history. If key **DISPLAY** is pushed in monitor mode, the LCD changes into alarm mode. The LCD changes automatically changes into alarm mode when an alarm is detected. Refer to Table 7-6 "Table of Alarms" and Table 7-7 "Table of Warnings" about alarm code.

Mode	Operation and LCD display	Description of display
ALARM LIST		<p>The currently detected error is displayed. If there is more than one error, all the errors can be displayed using the + and - keys</p> <p>ALARM No.2</p> <p>ALARM No.3</p> <p>ALARM No.4</p>
ALARM HISTORY		<p>Maximum ALARM No.99 HISTORY No.</p> <p>Dates and times are recorded as Greenwich Mean Time (GMT).</p>
ALARM HISTORY DETAILS		<p>The pump's operating status when an error is detected is displayed.</p>

SECTION 6 OPERATION

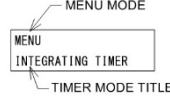
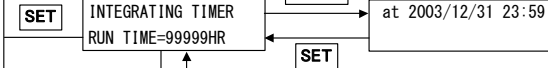
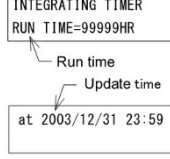
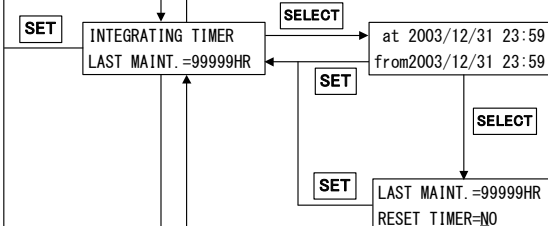
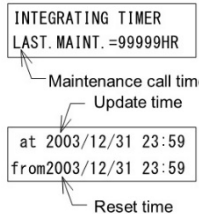
(3) MENU MODE / TIMER

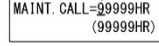
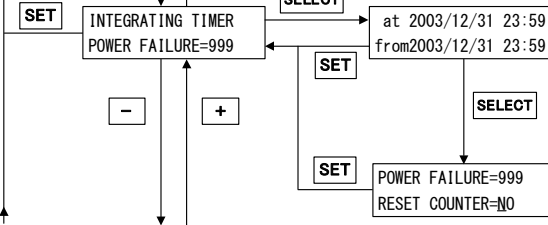
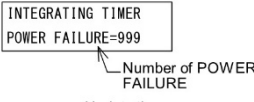
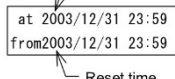
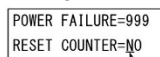
Mode	Operation and LCD display	Description of display
TIMER		
RUN TIME		<p>The pump's cumulative run time is displayed.</p> 
MAINTENANCE TIMER		<p>The pump's cumulative run time is displayed. Reset is possible at the same time as, for example, maintenance.</p>  <p>Select Reset Timer</p>  <p>Press the <input type="checkbox"/> or <input type="checkbox"/> key to select between NO or YES</p> <p>If the cumulative value for the maintenance call time exceeds the set value, alarm code 99 (maintenance call warning) occurs. Setting the set value to 0 disables this function.</p>  <p>Settings of Maintenance call time</p> <p>The value is changed using the <input type="checkbox"/> and <input type="checkbox"/> keys.</p>  <p>A cursor moves to the right when pushes SELECT key.</p>
POWER FAILURE TOUCH DOWN COUNTER		<p>The number of power failure touch-downs is counted. If this number exceeds 250, alarm code 12 (number of power failure touch-downs alarm) occurs. Refer to Section 7.5.3 for the appropriate remedy.</p>  <p>Number of POWER FAILURE</p> <p>Update time</p>  <p>Reset time</p> <p>Select Reset Counter</p>  <p>Press the <input type="checkbox"/> or <input type="checkbox"/> key to select between NO or YES</p>

HIGH SPEED TOUCH DOWN COUNTER

MB WARNING COUNTER

ROTOR TEMPERATURE COUNTER 1

ROTOR TEMPERATURE COUNTER 2

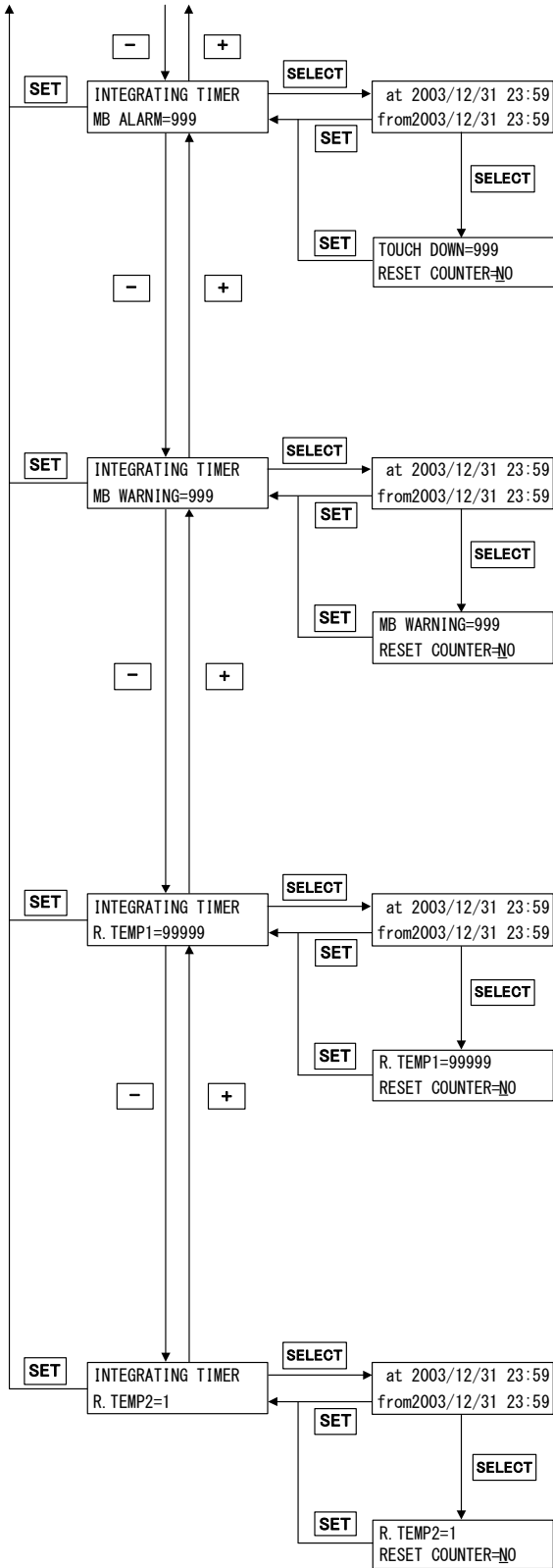

The number of alarms that occur for the magnetic bearing system at speeds exceeding 80 % of the rated speed is counted. If this number exceeds 10, alarm code 11 (number of high-speed touch-downs alarm) occurs.

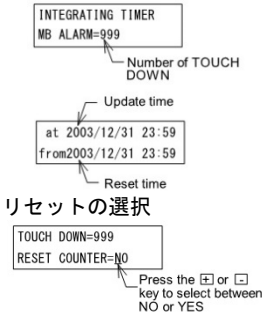

The number of warning that occur for the magnetic bearing system is counted.

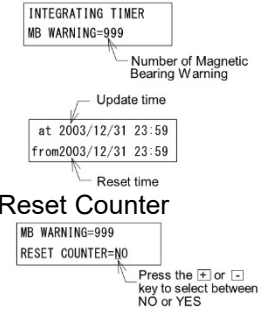

The cumulative value that rotor temperature is out of specification temperature is displayed. But, this function is invalid now because there is no appropriate pump for this function yet.

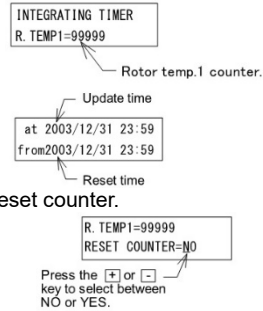

Alarm status generated when the rotor temperature is out of specification temperature is displayed. But, this function is invalid now because there is no appropriate pump for this function yet.

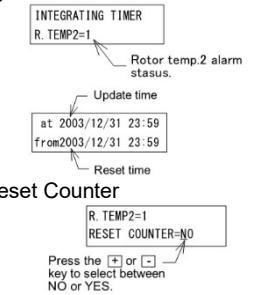

SECTION 6 OPERATION

(4) MENU MODE / SETTINGS

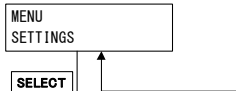
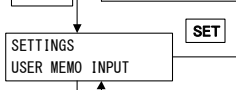
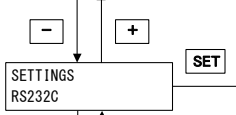
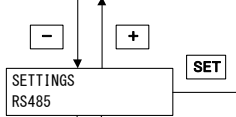
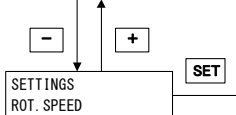
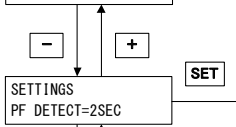
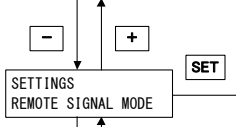
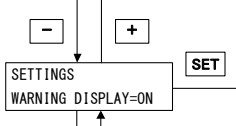
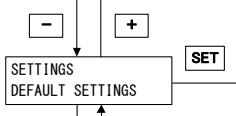
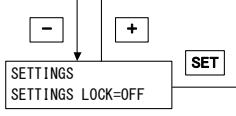
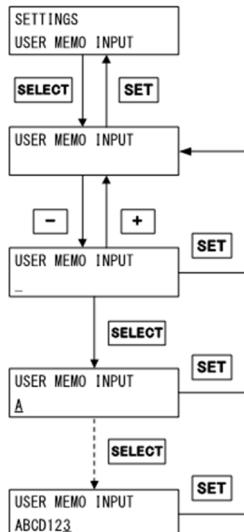
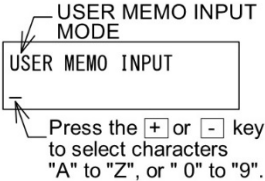
Mode	Operation and LCD display	Description of display
SETTINGS		Select settings mode
USER MEMO SETTINGS		Select user memo settings
RS-232C SETTINGS		Select RS-232C settings
RS-485 SETTINGS		Select RS-485 settings
ROTATIONALS PEED SETTINGS		Select rotational speed settings
POWER FAILURE DETECT SETTINGS		Select power failure detect settings
REMOTE-CONTROL SIGNAL SETTINGS		Select remote-control signal settings
WARNING OUTPUT SETTINGS		Select warning output setting
DEFAULT SETTINGS		Select default settings
LOCK SETTINGS		Select lock settings
USER MEMO SETTINGS		<p>Setting of any 20 characters is possible (Ex. Connection name of Turbo Molecular Pump). Characters are displayed during monitor mode.</p>  <p>Press the + or - key to select characters "A" to "Z", or "0" to "9".</p> <p>A cursor moves to the right when pushes SELECT key.</p>

Mode	Operation and LCD display	Description of display
RS-232C SETTINGS		<p>Baud rate setting</p> <p>Previous Setting</p> <p>Event Transmission Settings (Note 1)</p> <p>Previous Setting</p> <p>The event sending function is enabled or disabled. If set to ON, an event command is sent from the controller when an event occurs.</p>
RS-485 SETTINGS		<p>Baud rate setting</p> <p>Previous Setting</p> <p>Multi-drop setting (Note 1)</p> <p>Previous Setting</p> <p>Set ON to select the multi-drop mode.</p> <p>Network ID setting (Note 1)</p> <p>Previous Setting</p> <p>Setting required in multi-drop mode.</p> <p>Event Transmission Settings (Note 1)</p> <p>Previous Setting</p> <p>The event sending function is enabled or disabled. If set to ON, an event command is sent from the controller when an event occurs.</p>

Mode	Operation and LCD display	Description of display
<p>ROTATIONAL SPEED SETTINGS</p>		<p>Speed display setting</p> <p>Press the $\boxed{+}$ or $\boxed{-}$ key to select between %, rpm, or rps.</p> <p>DISPLAY=$\frac{\%}{\%}$ (%)</p> <p>Previous Setting</p> <p>The format of the motor speed display in the pump monitor mode is changed.</p> <p>Speed setting</p> <p>Press the $\boxed{+}$ or $\boxed{-}$ key to select between normal speed or low speed.</p> <p>SPEED=NORMAL (NORMAL)</p> <p>Previous Setting</p> <p>The pump rotates at the rated speed when NORMAL is selected. The pump rotates at the speed set with the low speed setting when LOW SPEED is selected. Refer to Section 6.5 "Variable Speed Operation"</p> <p>Low speed setting</p> <p>Press the $\boxed{+}$ or $\boxed{-}$ key to select a value between 50 and 100.</p> <p>LOW SP=100.0% (27000) (100.0%)</p> <p>Previous Setting</p> <p>When the speed setting is set to LOW speed or the remote-control signal designates low speed, the pump continues operation at the speed set by the low speed setting.</p>
<p>POWER FAILURE DETECT SETTINGS</p>		<p>Press the $\boxed{+}$ or $\boxed{-}$ key to select between 1SEC or 2SEC.</p> <p>PF DETECT=2SEC (1SEC)</p> <p>Previous Setting</p> <p>Set the time to detect power failure alarm.</p>

Mode	Operation and LCD display	Description of display
<p>REMOTE-CONTROL SIGNAL SETTINGS</p>		<p>“ALARM” signal setting of remote-control signal (Note 2)</p> <p>Press the [+] or [-] key to select between E1-03 or SEMI E74.</p> <p>ALARM=E1-03 (E1-03) Previous Setting</p> <hr/> <p>“REMOTE” signal setting of remote-control signal (Note 2)</p> <p>Press the [+] or [-] key to select between E1-03 or SEMI E74.</p> <p>REMOTE=E1-03 (E1-03) Previous Setting</p> <hr/> <p>“STOP” signal setting of remote-control signal (Note 2)</p> <p>Press the [+] or [-] key to select between remote only or remote & RSXXX.</p> <p>STOP=REMOTE ONLY (REMOTE ONLY) Previous Setting</p>
<p>WARNING OUTPUT SETTINGS</p>		<p>Press the [+] or [-] key to select between ON or OFF.</p> <p>WARNING DISPLAY=ON (ON) Previous Setting</p> <p>The setting changes the operation when warnings of alarm codes 86 to 98 (Refer to Table 7-7 "Table of Warnings") occur, as follows: ON: Buzzer ON, ALARM LED flashes, Error event sent to RS-232C and RS-485, The remote-control connector "WARNING" signal turn ON OFF: Buzzer OFF, ALARM LED OFF, No error event sent to RS-232C and RS-485, The remote-control connector "WARNING" signal turn off</p>
<p>DEFAULT SETTINGS</p>		<p>DEFAULT SETTINGS RESET SETTINGS=NO</p> <p>Press the [+] or [-] key to select between NO or YES.</p> <p>Select YES and push the [SET] key to return all the above items to their default settings. (Note 3)</p>
<p>LOCK SETTINGS</p>		<p>Press the [+] or [-] key to select between ON or OFF.</p> <p>SETTINGS LOCK=OFF (OFF) Previous Setting</p> <p>Set ON to disable changes on settings above mentioned.</p>

(Note 1) Refer to APPENDIX-A "COMMUNICATIONS" for details.

SECTION 6 OPERATION

(Note 2) Remote-control signal settings mode.

Signals		Description	Pin No.	
ALARM			(20)–(22)	(20)–(22)
	EI-03	Alarm occurrence	open	close
		Power OFF and no failure	close	open
	SEMIE 74 *1	Power OFF and alarm occurrence	close	open
		No failure	open	close
WARNING			(11)–(13)	(12)–(13)
	EI-03	Warning occurrence	open	close
		Power OFF and no failure	close	open
	SEMIE 74 *1	Power OFF and warning occurrence	close	open
		No failure	open	close
REMOTE	EI-03	“REMOTE” signal is OFF in power failure regeneration braking even if remote-controlled operation is available.		
	SEMIE 74 *1	“REMOTE” signal is always ON when remote-controlled operation is available.		
STOP	REMOTE ONLY	“STOP” signal ((16)-(14) open) is effective for only the time when remote-controlled operation is available.		
	REMOTE &RS-XXX	“STOP” signal ((16)-(14) open) is effective in operation by RS-232C or RS-485 set it in the cases that wants to use hardware inter rock.		

*1: When set to SEMI E74, behavior of remote-control signals conform to SEMI E74 standard "Specification for vacuum Pump Interface-Turbo Molecular Pumps".
Refer to the same standard about the shape of connectors and the pin configuration.

(Note 3)Default parameters

Function	Default settings
User memo	EI-R04M
RS-232C	BAUD RATE = 9600bps EVENT SENDING = ON
RS-485	BAUD RATE = 9600bps MULTIDROP = OFF NETWORK ID = 01 EVENT SENDING = ON
Variable speed	DISPLAY = % SPEED = NORMAL LOW SP = 100.0%
Power failure detect	PF DETECT = 1 sec
Remote-control signal	ALARM = EI-03 REMOTE = EI-03 STOP = REMOTE ONLY
Warning output setting	VWARNING DISPLAY = ON
Lock	SETTINGS LOCK = OFF

(5) MENU MODE / SELF TEST

Mode	Operation and LCD display	Description of display
LCD CONTRAST ADJUSTMENT		<div style="border: 1px solid black; padding: 5px; width: fit-content; margin-bottom: 10px;"> LCD CONTRAST PRESS +/- KEY </div> <p>Press the + or - key to adjustment of LCD contrast.</p>
SELF DIAGNOSIS		<p>Select YES and push the SET key to execute self diagnosis of the magnetic bearing sensor. If an abnormality is discovered by self diagnosis, alarm codes 81 to 85 occur. Refer to Section 7.5.3 for the appropriate remedy. This function can be used only when the pump is stopped.</p> <div style="border: 1px solid black; padding: 5px; width: fit-content; margin-bottom: 10px;"> SENSOR CHECK CHEK SENSOR=NO </div> <p>Press the + or - key to select between NO or YES.</p>
CORRESPONDING MODEL		<p>Displayed corresponding model that be available at this Controller. Push the + or - key to display all corresponding model.</p>

6.7 Remote-control Connector

6.7.1 Specifications

The controller is provided with remote-control connector for connection with remote operation, alarm signals, etc. Use this connector and a cable with shield as necessary. The shield of the cable should be connect to case of Remote-connector (Refer to Fig. 6-8, Fig. 6-9, Fig. 6-10 and Table 6-2, Table 6-3). For remote-controlled operation, push the REMOTE switch (Fig. 2-1 (15)) to REMOTE lamp ON.

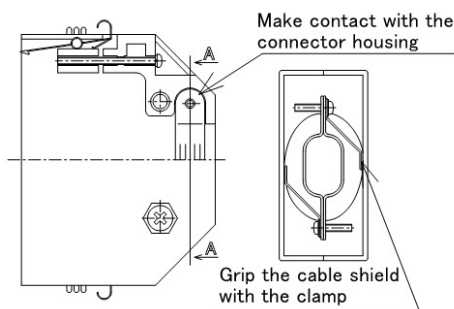

Fig. 6-8 Remote-control Connector

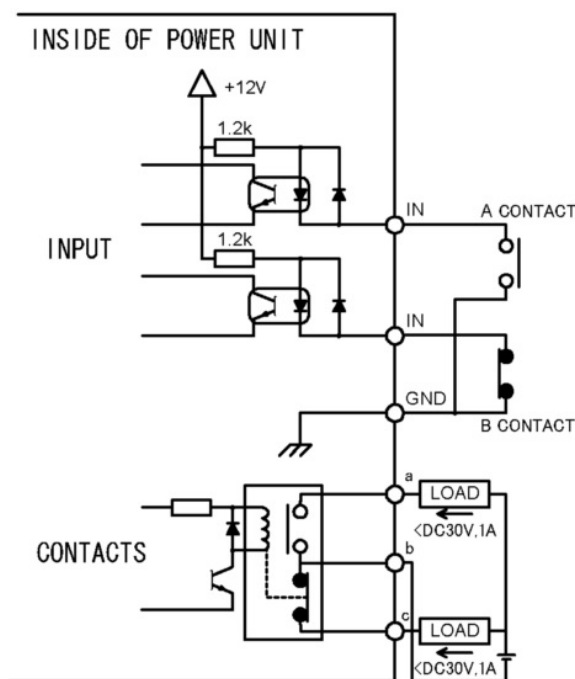

Fig. 6-9 Remote-control Circuit

Table 6-2 START/STOP According to Remote-control Signals

Connection method	By momentary type START/STOP switch	By alternate type switch
Wiring connection		
Control	Pump start by short-circuiting (15) and (14). Pump stop by opening(16) and (14).	Pump start, with the contact close or photo transistor ON ((16) to (14) short-circuit). Pump stop, with the contact open or photo transistor OFF ((16) to (14) open).
Electric capacity	[Contact] It is connected to +12 V circuit and subject to stable open-close of 5 VDC, 1 mA.Voltage...30 VDC or more, Current...10 mA or more [Photo transistor] Select a photo transistor with a collector-emitter voltage limit of 30 VDC and an on-state collector current of 10 mA or more.	
Input rating	Direct forward current 50 mA; DC reverse voltage 5 V	

Table 6-3 Remote-control Signals (Default Settings)

Classification	Signals	Pin No. (Note 1)	Operation (Note 2)	Electric spec.
Input	START	15	Starting operation on short-circuiting between GND and pin No.15. (Note 3)	Contact input
	STOP	16	Pump stop by opening GND and pin No.16. (Note 3) (Note 6)	
	RESET	17	Resetting operation on short-circuiting between GND and pin No.17.	
	LOW SPEED	33	Variable Speed Operation on short-circuiting between GND and pin No.33.	
	GND	14		
Output	ROTAION	29 4 30	During rotation; (29) - (30): open → close (make contact) (4) - (30): close → open (break contact)	Contact Output Contact capacity (resistance load) 30 VDC 1 A
	NORMAL	25 2 26	During normal rotation; (25) - (26): open → close (make contact) (2) - (26): close → open (break contact)	
	ACCELERATION	23 1 24	During acceleration; (23) - (24): open → close (make contact) (1) - (24): close →open (break contact)	
	BRAKE	27 3 28	During deceleration; (27) - (28): open → close (make contact) (3) - (28): close → open (break contact)	
	REMOTE	31 5 32	Remote-controlled operation is available; (31) - (32): open → close (make contact) (5) - (32): close → open (break contact)(Note 6)	
	ALARM (Note 5)	21 20 22	Against alarm; (21) - (22): open → close (make contact) (20) - (22): close → open (break contact)(Note 6)	
	WARNING (Note 5)	12 11 13	Against warning; (12) - (13): open → close (make contact) (11) - (13): close → open (break contact)(Note 6)	

(Note 1) Don't connect any pins other than specified above.

(Note 2) Approximately 6 seconds is required for the remote control signal to turn on after the POWER switch is turned on.

(Note 3) "STOP" signal is prior to "START" signal.

(Note 4) One reset signal is received each time when the contact closes. Repeatedly short and open the contact to input multiple reset signals. Refer to Section 7.5.3 "Reset Procedure" for details about the error-reset procedure.

(Note 5) Refer to Table 7-6 "Table of Alarms" and Table 7-7 "Table of Warnings" about alarm and warning.

(Note 6) It is possible to change movement by remote-control signal settings of settings mode (Refer to Section 6.6 "Software Operation" (4)).

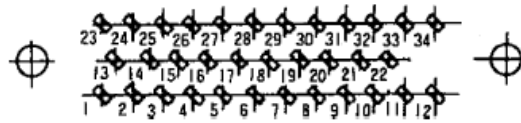

Fig. 6-10 Arrangement of Remote-control Connector Pins

(The controller rear panel attachment connectors, as viewed from the front)



TROUBLESHOOTING



- 7.1 Nothing Happens After an Operation is Made
- 7.2 Power Failures
 - 7.2.1 Power Failure Counter-operation
- 7.3 Vacuum Pressure Rise
- 7.4 Abnormal Noise and/or Vibration
- 7.5 Alarm Detection Capabilities
 - 7.5.1 Movement in Alarm Detection Capabilities (ALARM)
 - 7.5.2 Movement in Alarm Detection Capabilities (WARNING)
 - 7.5.3 Reset Procedure

7.1 Nothing Happens After an Operation is Made

Table 7-1 Nothing Happens After an Operation is Made

	Problem	Possible causes	Corrective action
1	Power ON/OFF switch in the ON position but the turbo molecular pump fails to operate.	Electrical power cable not properly connected.	Properly connect the electrical power cable.
		Electrical power outside controller power range.	Operate within controller power range.
2	START switch is pushed but turbo molecular pump does not accelerate.	REMOTE lamp ON.	Push the REMOTE switch to turn off the REMOTE lamp.
		Other causes.	Check the controller ALARM lamp is not ON. If an alarm is indicated, correct the malfunction and reset the controller.
3	Remote "START" signal active but the turbo molecular pump does not accelerate.	REMOTE lamp OFF.	Push the REMOTE switch to turn on the REMOTE lamp.
		"STOP" signal active.	Deactivate "STOP" signal.
		Other problems	Check the unit's ALARM lamp is not ON. If an alarm is indicated, correct the malfunction and reset the controller.
4	STOP switch is pushed but the turbo molecular pump does not decelerate.	REMOTE lamp ON.	Push the REMOTE switch to turn off the REMOTE lamp.
5	Remote "STOP" signal activated but the turbo molecular pump does not decelerate.	REMOTE lamp OFF.	Push the REMOTE switch to turn on the REMOTE lamp.

7.2 Power Failures

When a power interruption occurs, the motor inside the turbo molecular pump immediately begins regenerative braking. The magnetic bearing will use this generated electricity to keep functioning and the rotor inside the turbo molecular pump will continue being levitated. The rotation will slow down due to the regenerative braking and eventually the rotor will be supported by the touchdown bearing. Table 7-2 shows the number of revolutions and period of time that will elapse before being supported by the touchdown bearing, when the power fails at the rated speed.

Table 7-2 Time and Rotational Speed During a Power Interruption Before being Supported by Touchdown Bearing

Pump model	Rotational speed before support by touchdown bearing	Period of time before support by touchdown bearing (Note 1)
UTM800A-MS	7200rpm	about 4 minutes
UTM1000A-MS		
UTM1300A-MS	7800rpm	about 5.5 minutes
UTM1500A-MS		

(Note 1) The time is typical for regenerative braking from the rated speed.

Actual time will vary depending on vacuum conditions inside the pump and the rotational speed when the power fails.

7.2.1 Power Failure Counter-operation

Table 7-3 shows the counter-operations against power failure which occurred while the pump rotor is normally rotating.

Table 7-3 Counter-operations Against Power Failure

Interruption time	1 second or less (Note 1)		Over 1 second (Note 1)	
Interrupt/re-supply	During interruption	After re-supply	During interruption	After re-supply
Pump status				
Magnetic levitation	Levitation goes on.	Levitation goes on.	Levitation goes on.	Levitation goes on.
Run	Decelerates	Returns to before-power-failure running condition	Decelerates	Decelerates (Note 1)
Indicator lamp				
ROTATION NORMAL SPEED ALARM	Lamp ON goes on Before-power-failure Before-power-failure	Lamp ON goes on Before-power-failure Before-power-failure	Lamp ON goes on Turns off Turns on	Lamp ON goes on Lamp OFF goes on Lamp ON goes on
Remote-control output signals (Note 3)				
ROTATION Pin no.(29)–(30) (4)–(30)	"CLOSE" goes on "OPEN" goes on	"CLOSE" goes on "OPEN" goes on	"CLOSE" goes on "OPEN" goes on	"CLOSE" goes on "OPEN" goes on
NORMAL Pin no.(2)–(26) (25)–(26)	Before-power-failure condition goes on. Before-power-failure condition goes on.	Before-power-failure condition goes on. Before-power-failure condition goes on.	Contact close Contact open	"CLOSE" goes on "OPEN" goes on
ACCELERATION Pin no.(1)–(24) (23)–(24)	Before-power-failure condition goes on. Before-power-failure condition goes on.	Before-power-failure condition goes on. Before-power-failure condition goes on.	Contact close Contact open	"CLOSE" goes on "OPEN" goes on
BRAKE Pin no.(27)–(28) (3)–(28)	Before-power-failure condition goes on. Before-power-failure condition goes on.	Before-power-failure condition goes on. Before-power-failure condition goes on.	Contact close Contact open	"CLOSE" goes on "OPEN" goes on
REMOTE Pin no.(31)–(32) (5)–(32)	Before-power-failure condition goes on. Before-power-failure condition goes on.	Before-power-failure condition goes on. Before-power-failure condition goes on.	Contact open Contact close	Return to Before- power-failure condition. Return to Before- power-failure condition.
ALARM Pin no.(21)–(22) (20)–(22)	"CLOSE" goes on "OPEN" goes on	"CLOSE" goes on "OPEN" goes on	Contact open Contact close	By resetting, "CLOSE" → "OPEN" "OPEN" → "CLOSE"
WARNING Pin no.(12)–(13) (11)–(13)	"OPEN" goes on "CLOSE" goes on	"OPEN" goes on "CLOSE" goes on	"OPEN" goes on "CLOSE" goes on	By resetting, "OPEN" goes on "CLOSE" goes on
Buzzer	Does not sound	Does not sound	(Note 2) Before resetting: Sounds After resetting: Released (reset)	(Note 2) Before resetting: Sounds After resetting: Released (reset)

(Note 1) Replace 1 second by 2 seconds, if "2sec" is selected in POWER FAILURE DETECT SETTINGS.

(Note 2) For restarting after the power re-supply (restoration), push the RESET switch twice and, thereafter, perform the start-up operation. First pushing of the RESET releases the buzzer and second pushing of the RESET releases "ALARM" signal.

(Note 3) The pin numbers are shown in Fig. 6-10 "Arrangement of Remote-control Connector Pins".

(Note 4) The ALARM, WARNING and REMOTE signal activity will change depending on the SETTINGS / REMOTE SIGNAL MODE menu settings on the LCD display. For more information, refer to Section 6.6 "Software Operation".

7.3 Vacuum Pressure Rise

A rapid rise of vacuum pressure in the turbo molecular pump causes the internal motor of the turbo molecular pump to start braking and the ALARM lamp (Fig. 2-1 (14)) lights.

Be careful to prevent a rapid pressure rise or air rush during operation.

7.4 Abnormal Noise and/or Vibration

Should the turbo molecular pump ever generate abnormal noise and/or vibration, the turbo molecular pump operation is to be stopped immediately.

But there is possible that a race of touch-down bearing may make sounds for seconds when the pump internal pressure gets back to atmospheric pressure using air (or non-activity gas). This phenomena is not abnormal and make no damage to the pump, because the air whirlpool sometimes occurs and then makes the touch-down bearing rotate slightly.

NOTICE

When turning the POWER switch for the controller on or off, a "clunk" sound may be heard from inside the pump. This sound is from the rotor inside the pump being levitated or de-levitated. This is normal.

7.5 Alarm Detection Capabilities

The fault detection functions shown in Table 7-6 "Table of Alarms" and Table 7-7 "Table of Warnings" are incorporated for protection in the event of a problem with the turbo molecular pump or controller.

When an error is detected, check the ALARM lamp (Fig. 2-1 (14)) and the alarm mode display on the front panel (Refer to Section 6.6 "Software Operation" (2)) and refer to Section 7.5.3 "Reset Procedure" for the appropriate remedy.

7.5.1 Movement in Alarm Detection Capabilities (ALARM)

1. ALARM lamp (Fig. 2-1 (14)) lights.
2. Alarm description is displayed on LCD.
3. The remote-control connector "ALARM" signal turn ON.
4. The buzzer sounds.
5. The pump start the protective operations shown in Table 7-6 "Table of Alarms".
6. The detection error is recorded in the error log.

7.5.2 Movement in Alarm Detection Capabilities (WARNING)

The warning output setting in the menu mode "SETTINGS / WARNING DISPLAY" item on the LCD changes the operation when a warning occurs.

<When the warning output setting is ON>

1. ALARM lamp (Fig. 2-1 (14)) flashes.
2. Warning description is displayed on LCD.
3. The remote-control connector "WARNING" signal turn ON.
4. The buzzer sounds.
5. Pump operation continues.
6. The detection error is recorded in the error log.

<When the warning output setting is OFF>

[When warnings of alarm codes except 86 to 98 occur.] (Refer to Table 7-7 "Table of Warnings".)

The operation is the same as the warning output setting is ON.

[When warnings of alarm codes 86 to 98 occur.] (Refer to Table 7-7 "Table of Warnings".)

- (1. ALARM lamp (Fig. 2-1 (14)) does not flash.)
 2. Warning description is displayed on LCD.
 - (3. The remote-control connector "WARNING" signal do not turn ON.)
 - (4. The buzzer does not sound.)
 5. Pump operation continues.
 6. The detection error is recorded in the error log.
-

7.5.3 Reset Procedure

1. The buzzer stops after the first reset operation.
2. Refer to the Troubleshooting information and eliminate the cause of the problem.
3. Conduct the reset operation again.
4. (ALARM) If the problem has been eliminated, the ALARM lamp (Fig. 2-1 (14)) goes out, the "ALARM" remote-control signals (Refer to Table 6-3) turn off after an alarm was given, the pump rotor decelerates rotational speed.

(WARNING) When the problem is eliminated after a warning occurred, pump operation continues.

5. If the problem was not completely eliminated, the buzzer sounds again and the error is detected.

(Note) When the buzzer does not sound and if the warning output setting is OFF in the menu mode SETTINGS / WARNING DISPLAY item on the LCD, the first reset operation after a warning occurs is equivalent to the third reset operation.

Table 7-4 If the ALARM Lamp Lights

	LCD display	Possible cause	Remedy	Section
1	11=TD COUNTER LIMIT 12=PF COUNTER LIMIT	The number of high speed or power failure touch-downs has exceeded the prescribed number.	The touch-down bearing may have deteriorated. Consult ULVAC KIKO or an approved service company regarding replacement of the touch-down bearing.	
2	13=WRONG TMP MODEL	The models of pump and controller do not match.	Check the combination of the pump and controller models. Corresponding model can be confirm in menu mode SELF TEST / AVAILABLE TMP. Check the connection of the control cable. Also check that the connector pins are not bent. Turn off the controller before checking the control cable. Never disconnect the cable while the power is on.	6.6 5.3
3	14=ACLOWVOLTAGE 15=POWER FAILURE	Power failure or reduction in the controller voltage.	Wait for the power to be restored. An unfamiliar sound will be heard a few minutes after a power failure. This sound occurs when the rotor contacts the protective bearing as magnetic levitation cannot be maintained. This is not an abnormal sound.	
		POWER switch was turned off by mistake.	Wait about 5 seconds before turning the POWER switch back on. Re-acceleration is possible after resetting and start-up.	
4	16=TMP:OVERLOAD	Drop in rotation speed during rotation at rated speed (increased internal pump pressure).	Check that the outlet and inlet pressures are below the specified maximum pressures. Check for leakage. Check that too much purge gas is not flowing. Check that process gas flow rate is not too high.	

	LCD display	Possible cause	Remedy	Section
5	21=TMP TEMP/MB CABLE	High pump unit temperature.	Check that the ambient temperature around the pump is within the specified range. Check that the temperature and flow rate of the cooling water are within the specified ranges. Check that no load in excess of the specified range is continuously applied to the pump.	
		Control cable is not connected correctly.	Check the connection of the control cable. Also check that the connector pins are not bent. Turn off the controller before checking the control cable. Never disconnect the cable while the power is on.	5.3
6	22=TMP:SENSOR ERROR 46=MOTOROVERSPEED 47=EI:R-SPEED ERROR	Rotation detection signal from the motor cannot be detected correctly.	Check that equipment causing noise is not used around the controller, pump unit, motor cable, or control cable.	5.1 5.2 5.3
7	23=EI:MOTOR OVERCURR 34=EI:INV.OVERCURR	Overcurrent supplied to the motor.	Check the motor cable and control cable. (Check for connection and wiring likely to cause disconnection or short circuit)	
8	31=EI:BR OVERTEMP 32=EI:DC-DCOVERTEMP	Temperature increase in the controller.	Check that the ambient temperature around the controller is within the specified range. Check the ventilation of the controller.	4.1 5.1
9	33=EI:FAN ERROR	Fan stopped.	Check that the fan on the controller rear panel is operating. Remove any object obstructing its operation.	5.1
10	35=EI:INV.OVERVOLT 36=EI:DC-DC LOW VOLT 37=EI:DC-DC OVERCURR 38=EI:DC-DCOVERVOLT 45=EI:BRAKEOVERTIME	Defective circuit in the controller.	Turn the power on again after the pump stops. The controller must be repaired if the problem occurs again.	
11	43=EI:PARAM ERROR	Defective circuit in the controller.	Turn the power on again after the pump stops. The controller must be repaired if the problem occurs again.	
12	44=EI:CPU ERROR 66=MB:DSP ERROR 67=MB:DSP OVERFLOW	Abnormal operation of circuit in the controller.	Check that the ambient temperature around the controller is within the specified range. Check that equipment causing noise is not used around the controller, pump unit, motor cable, or control cable.	4.1 5.1 5.2 5.3
13	48=EI:ACCEL OVERTIME	Rotation speed does not increase at start-up.	Check that the outlet and inlet pressures are not too high. Check for leakage. Check that too much purge gas is not flowing.	6.2

	LCD display	Possible cause	Remedy	Section
14	49=TMP:CAN NOT START	Pump does not rotate.	Adhesion of reaction products or damage to the protective bearing is the possible cause. Remove the pump from the unit and check that the rotor blades rotate smoothly at the inlet. An overhaul is required if blades do not rotate smoothly. Check the connection of the control cable and the motor cable. Also check that the connector pins are not bent and that the connector is fully inserted. Turn off the controller before checking the cables. Never disconnect the cable while the power is on.	
15	51=MB:VIBRATION2 X1 52=MB:VIBRATION2 Y1 53=MB:VIBRATION2 X2 54=MB:VIBRATION2 Y2 55=MB:VIBRATION2 Z 56=MB:VIBRATION1 X1 57=MB:VIBRATION1 Y1 58=MB:VIBRATION1 X2 59=MB:VIBRATION1 Y2 60=MB:VIBRATION1 Z	Strong external shock or vibrations.	If the shock or vibrations are transient, re-acceleration is possible. If the shock or vibrations occur frequently, stop the pump and remove the source of the shock or vibrations; or re-examine the pump mounting method.	
16	61=MB:SENSOR ERR. X1 62=MB:SENSOR ERR. Y1 63=MB:SENSOR ERR. X2 64=MB:SENSOR ERR. Y2 65=MB:SENSOR ERR. Z	Control cable is not connected correctly.	Check the connection of the control cable. Also check that the connector pins are not bent. Turn off the controller before checking the control cable. Never disconnect the cable while the power is on.	5.3
		The rotor does not move due to adhering matter or a damaged touch-down bearing.	Remove the pump and check that the rotor rotates smoothly. The pump requires an overhaul if the rotor does not rotate or the resistance to rotation is large.	
17	68=MB:BALANCE AXIS1 69=MB:BALANCE AXIS2	Rotor inside the pump is out of balance.	Adhesion of reaction products is a possibility. An overhaul is required.	

Table 7-5 If the ALARM Lamp Flashes

	LCD display	Possible cause	Remedy	Section
1	80=EI:CONT.TEMP.WARN	Temperature increase in the controller.	Check that the ambient temperature around the controller is within the specified range. Check the ventilation of the controller.	4.1 5.1
2	81=MB:SELFCHECK X1 82=MB:SELFCHECK Y1 83=MB:SELFCHECK X2 84=MB:SELFCHECK Y2 85=MB:SELFCHECK Z	Rattling of the protective bearing becomes pronounced.	Deterioration of the protective bearing is likely. Overhaul as soon as possible to avoid damage to the protective bearing in the event of a power failure etc.	
3	86=MB:VIB.WARN.X1 87=MB:VIB.WARN.Y1 88=MB:VIB.WARN.X2 89=MB:VIB.WARN.Y2 90=MB:VIB.WARN.Z	Transient strong external shock or vibrations.	Continuous operation is possible. However, if the shock or vibrations occur frequently, stop the pump and remove the source of the shock or vibrations; or re-examine the pump mounting method.	
4	91=MB:BALANCE WARN.1 92=MB:BALANCE WARN.2	Rotor inside the pump is out of balance.	Adhesion of reaction products is a possibility. An overhaul is recommended.	
5	94=MB:AIR RASH B	Atmospheric penetration has occurred.	Create a vacuum system not allowing atmospheric penetration by re-examining the operating sequence of the back pump and valves etc.	
6	95=DSP WARNING	Abnormal operation of circuit in the controller.	Check that the ambient temperature around the controller is within the specified range. Check that equipment causing noise is not used around the controller, pump unit, motor cable, or control cable.	4.1 5.1 5.2 5.3
7	99=MAINTENANCE TIME	Maintenance call timer has reached the set time.	Implement maintenance works prescribed by the customer, such an overhaul. The alarm can be cancelled by resetting the maintenance call timer after implementing necessary works.	6.6

(Note) When warnings of alarm codes 86 to 95 (Refer to Table 7-7 "Table of Warnings") occur, the alarm lamp does not flash and the display appears on the LCD only if the warning output setting is OFF in the menu mode SETTINGS / WARNING DISPLAY item on the LCD.

Table 7-6 Table of Alarms

Alarm code	LCD display	Cause	Protective action
11	11=TD COUNTER LIMIT	Counts of the high speed touch-down counter exceeded the specified number.	Start-up impossible (detected during controller self-diagnostics)
12	12=PF COUNTER LIMIT	Counts of the power failure touch-down counter exceeded the specified number.	
13	13=WRONG TMP MODEL	The combination of the pump and controller is wrong.	
14	14=AC LOW VOLTAGE	Fall in AC input power voltage.	Regenerative braking
15	15=POWER FAILURE	Power failure.	
16	16=TMP:OVERLOAD	After accelerating to 80 % of the designated speed or low-speed setting, the speed dropped below 80 % due to overloading etc.	Deceleration
21	21=TMP TEMP/MB CABLE	Increased pump drive motor temperature.MB cable is not connected.	Free run (motor stop)
22	22=TMP:SENSOR ERROR	Pump rotation signal could not be detected correctly.	
23	23=EI:MOTOR OVERCURR	Overcurrent ran through the motor	
31	31=EI:BR OVER TEMP	Increased temperature inside controller.	Free run (motor stop)
32	32=EI:DC-DC OVER TEMP	Increased temperature inside controller.	
33	33=EI:FAN ERROR	Controller cooling fan has stopped.	
34	34=EI:INV.OVERCURR	Overcurrent ran through the motor.	
35	35=EI:INV.OVERVOLT	Defective circuit in the controller.	
36	36=EI:DC-DC LOW VOLT	Defective circuit in the controller.	Regenerative braking
37	37=EI:DC-DC OVERCURR	Defective circuit in the controller.	Deceleration
38	38=EI:DC-DC OVERVOLT	Defective circuit in the controller.	
43	43=EI:PARAM ERROR	Stored parameters are not correct.	Start-up impossible (detected during controller self-diagnostics)
44	44=EI:CPU ERROR	Error in the CPU for inverter control.	Free run (motor stop)
45	45=EI:BRAKE OVERTIME	Pump does not stop within the specified time after the stop operation.	
46	46=MOTOROVERSPEED	Pump rotation speed is too high.	
47	47=EI:R-SPEED ERROR	Pump rotation speed cannot be detected.	
48	48=EI:ACCEL OVERTIME	Pump does not accelerate to 80 % of the designated speed or low-speed setting within the specified time after start-up.	Deceleration
49	49=TMP:CAN NOT START	Pump fails to rotate within 2 minutes after start-up.	

SECTION 7 TROUBLESHOOTING

Alarm code	LCD display	Cause	Protective action
51	51=MB:VIBRATION2 X1	Continuous excessive vibration of the magnetic bearing.	Deceleration
52	52=MB:VIBRATION2 Y1		
53	53=MB:VIBRATION2 X2		
54	54=MB:VIBRATION2 Y2		
55	55=MB:VIBRATION2 Z		
56	56=MB:VIBRATION1 X1	Excessive magnetic bearing vibration.	
57	57=MB:VIBRATION1 Y1		
58	58=MB:VIBRATION1 X2		
59	59=MB:VIBRATION1 Y2		
60	60=MB:VIBRATION1 Z		
61	61=MB:SENSOR ERR. X1	Abnormal output signal from the magnetic bearing sensor.	
62	62=MB:SENSOR ERR. Y1		
63	63=MB:SENSOR ERR. X2		
64	64=MB:SENSOR ERR. Y2		
65	65=MB:SENSOR ERR. Z		
66	66=MB:DSP ERROR	Error in the DSP for magnetic bearing control.	
67	67=MB:DSP OVERFLOW	Overflow in the magnetic bearing control calculations.	
68	68=MB:BALANCE AXIS1	Rotor is out of balance.	
69	69=MB:BALANCE AXIS2		

Table 7-7 Table of Warnings

Alarm code	LCD display	Cause	Protective action
80	80=EI:CONT.TEMP.WARN	Increased temperature inside controller.	Operation continued.
81	81=MB:SELFCHECK X1	Results of magnetic bearing sensor self-diagnostics are abnormal.	Operation is possible (detected during controller self-diagnostics).
82	82=MB:SELFCHECK Y1		
83	83=MB:SELFCHECK X2		
84	84=MB:SELFCHECK Y2		
85	85=MB:SELFCHECK Z		
86	86=MB:VIB.WARN.X1	Vibrations of the magnetic bearing become temporarily excessive.	Operation continued.
87	87=MB:VIB.WARN.Y1		
88	88=MB:VIB.WARN.X2		
89	89=MB:VIB.WARN.Y2		
90	90=MB:VIB.WARN.Z		
91	91=MB:BAL.WARN.AXIS1	Rotor is slightly out of balance.	
92	92=MB:BAL.WARN.AXIS2		
94	94=MB:AIR RASH B	Atmospheric penetration.	
95	95=DSP WARNING	Error in the DSP for magnetic bearing control	
99	99=MAINTENANCE TIME	Maintenance call timer reaches its set time	

No Text

Appendix A

COMMUNICATION



- A1 GENERAL SPECIFICATION
- A2 INTERFACE SPECIFICATION
- A3 CONTROLLER TO COMPUTER CONNECTION
- A4 SERIAL COMMUNICATIONS PROTOCOL
- A5 TABLE OF COMMANDS
- A6 COMMAND DESCRIPTION
- A7 RS-232C COMMANDS / ANSWERS(SEND AND RECEIVE Examples)
- A8 RELATION OF LOCAL MODE TO REMOTE MODE OPERATIONS
- A9 TROUBLESHOOTING

A1 GENERAL SPECIFICATION

The controller contain serial interfaces conforming to RS-232C and RS-485 specifications. The following functions are available by connecting a computer with communication capacity to these interfaces and creating the appropriate software.

The RS-232C and RS-485 interfaces can be used simultaneously, permitting simultaneous access from two computers. Also, the RS-485 interface permits multi-drop connections, allowing multiple controller to be connected to a single computer.

1. Checking current operation mode: The serial interfaces allow the user to check the status of REMOTE lamp (REMOTE/LOCAL). In REMOTE mode, the user can change the operation mode to RS-232C or RS-485.
2. Operation: Operations equivalent to the START, STOP, and RESET switches are available in the RS-232C or RS-485 operation mode. Also, the speed setting can be made using the set value write function.
3. Checking turbo molecular pump run status: The serial interfaces allow the user to check the current turbo molecular pump's running status (Normal rotation, Accelerating, Decelerating, failure occurrence, etc.).
4. Reading parameters: The serial interfaces allow the user to read a variety of turbo molecular pump parameters such as pump rotational speed and motor current which are stored in the controller.
5. Receiving events: The controller can transmit status commands for events such as failure occurrences, rotation start and stop, and attainment of normal rotation speed.
6. Reading history data: The serial interfaces allow the user to read the alarm history data displayed in the LCD display history mode.
7. Reading and writing timer data: The serial interfaces allow the user to read the timer and counter values displayed in the LCD display timer mode and to reset the counters.
8. Reading and writing settings data: The serial interfaces allow the user to read and change settings in the LCD display setting mode.

A2 INTERFACE SPECIFICATION

A2.1 RS-232C

A2.1.1 Transmission Specification

Interface	RS-232C
Synchronous system	Asynchronous
Transmission rate	1200, 2400, 4800, 9600 and 19.2 k bits per second (Refer to Section 6.6 "Software Operation" (4) for settings)
Character configuration	Start bit: 1 Data bits: 8 Parity: None Stop bit: 1
Flow control	None

A2.1.2 Communications Connector

Connector	Front panel RS-232C connector (Refer to Section 2.1 "Controller")
Connector type	D-sub 9 pin Male, Screw lock size: M2.6
Pin assignment	2: RD (Receive data) 3: SD (Transmit data) 5: SG (Signal ground) *Other pins are not connected.

A2.1.3 CABLE

(1) Cable connection

Use the connection cable as shown in Fig. A-1 to connect the controller and computer (Number on figure is pin number of connector).

(2) Cables used

For connection with this connector, the communication cable with shield is necessary. The shield of the cable should be connected to case.

(3) Cable length

Connection cables can be extended up to 15 meters, but may be subjects to errors depending on actual operational environment.

a. Cable wiring connections for 9-pin to 9-pin connector cables.

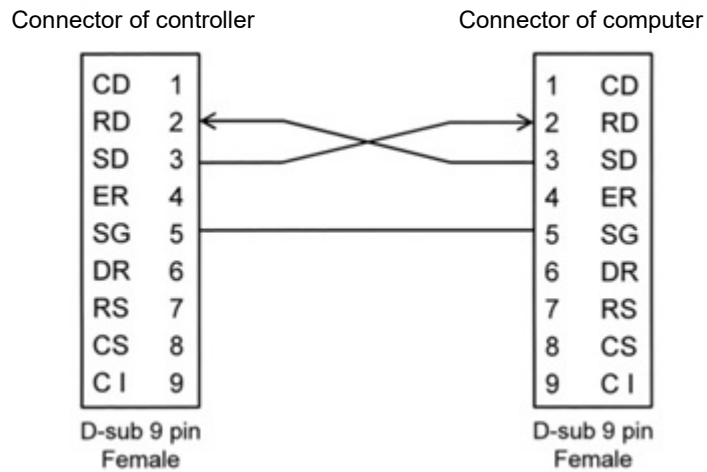

b. Cable wiring connections for 9-pin to 25-pin connector cables.

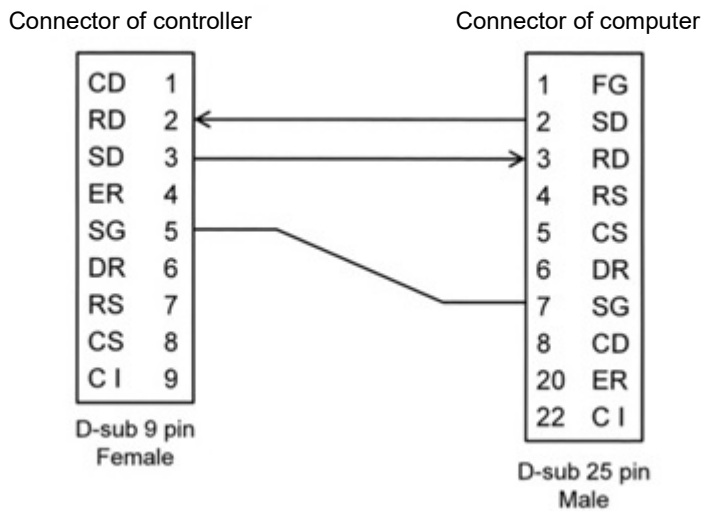

Fig. A-1 Example of RS-232 Cable Wiring Connections

A2.2 RS-485

A2.2.1 Transmission Specification

Interface	RS-485
Synchronous system	Asynchronous
Transmission rate	1200, 2400, 4800, 9600 and 19.2k bits per second (Refer to Section 6.6 "Software Operation" (4) for settings)
Character configuration	Start bit: 1 Data bits: 8 Parity: None Stop bit: 1
Flow control	None
Number of controller	Multi-drop function OFF: 1 Multi-drop function ON: Max 32 (*1)

*1 : There may be restrictions depending on cable length or cable type. Perform appropriate checks in the actual operating environment.

A2.2.2 Communications Connector

Connector	Rear panel RS-485 connector (Refer to Section 2.1 "Controller")
Connector type	D-sub 9 pin Female, Screw lock size: M2.6
Pin assignment	1, 6: RxA (Receive data +) 2, 7: RxB (Receive data -) 3, 8: TxB (Transmit data -) 4, 9: TxA (Transmit data +) *Other pins are not connected.

A2.2.3 CABLE

(1) Cable Connection

a. Multi-drop function OFF

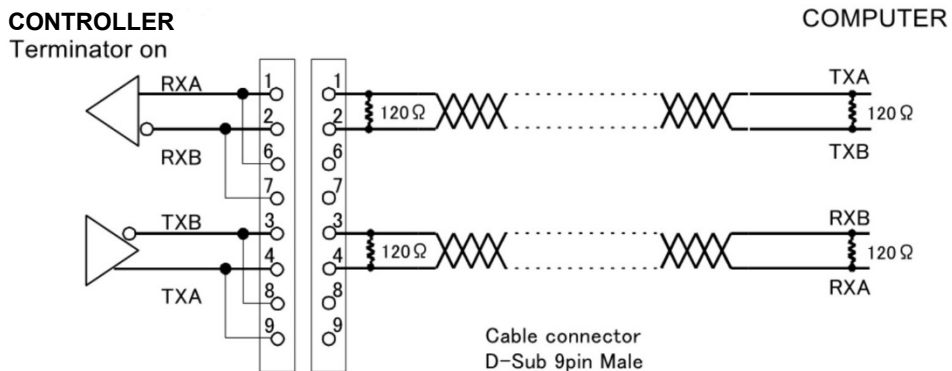

Fig. A-2 Example of RS-485 Cable Wiring Connections (Multi-drop function OFF)

b. Multi-drop function ON

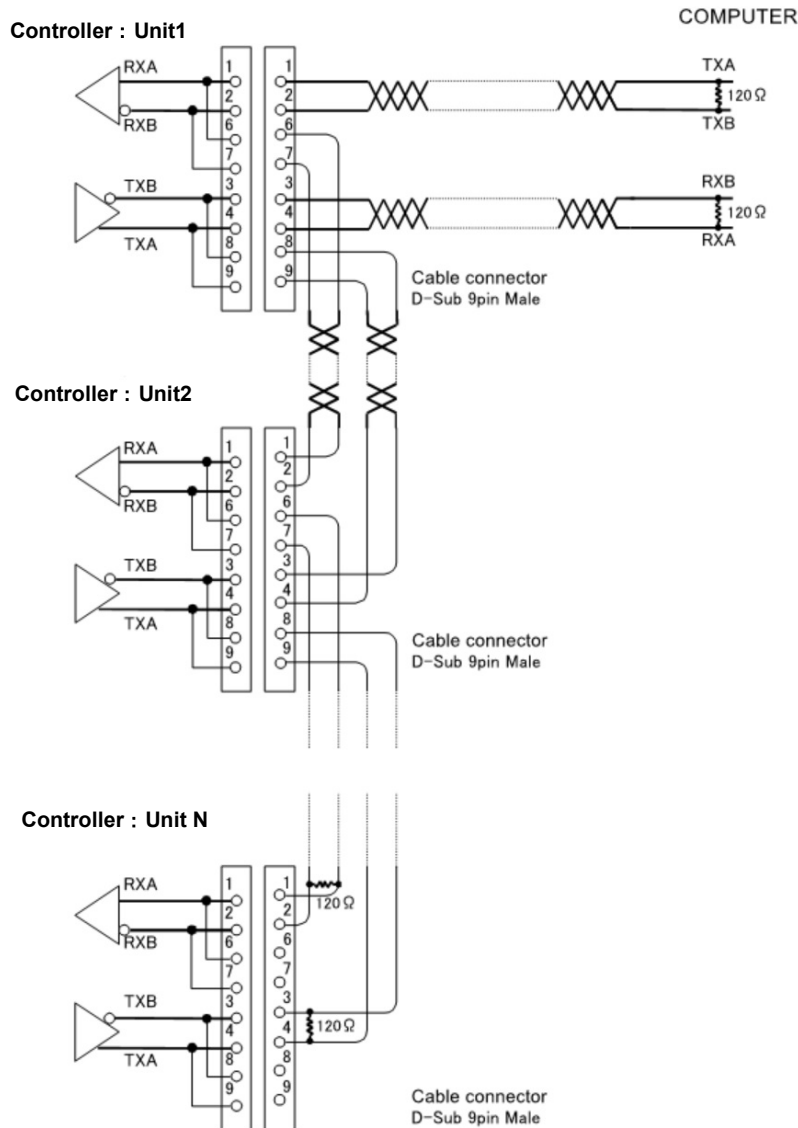

Fig. A-3 Example of RS-485 Cable Wiring Connections (Multi-drop function ON)

(2) Cables used

RS-485 is a differential transmission and use twisted-pair cables in combinations as shown in Fig. A-2 and Fig. A-3. The shield of the cable should be connected to case.

(3) Connecting the terminator

A terminator (120 Ω , 1/4 W min.) is required for connection.

Terminators are not necessary for multi-dropped turbo molecular pump with another pump or pump to which the computer connects is connected to both ends (pump 1 through N in Fig. A-3). However, connection of the terminator may prevent communications with certain cable lengths and RS-485 device types. Connect the terminator to determine whether it is required.

(4) Cable length

Connection cables can be extended up to 1.2 kilometers, but may be subjects to errors depending on actual operational environment.

NOTICE

Serial communication specifications conform to RS-232C and RS-485.

These interfaces were tested on a typical condition, but the normal communication with all equipments are not guaranteed.

A3 CONTROLLER TO COMPUTER CONNECTION

A3.1 Communication Cable Connection

Turn off the controller and the computer to be connected. Connect the RS-232C connector on the controller front panel or the RS-485 connector on the rear panel (Refer to Section 2.1 in this document, "Controller") to the communications port of the computer with a cable, referring to Section A2 "INTERFACE SPECIFICATION".

A3.2 Serial Communications Baud Rate Configuration

Check with a baud rate of a computer connected to, and set up a baud rate of RS-232C or RS-485. Refer to Section 6.6 "Software Operation" (4) for details about the setting method.

A3.3 RS-485 Multi-drop Settings

The RS-485 interface multi-drop function is used to connect multiple controllers to a single computer. Turn off the multi-drop function if the RS-485 is used instead of RS-232C to extend the communication cable length.

When the multi-drop function is turned on, the network ID portion of the sent character strings (Refer to Section A4 "SERIAL COMMUNICATIONS PROTOCOL") is enabled and the event communication function that notifies the controller status to the connected computer is disabled.

Set up the RS-485 as described below when using a multi-drop connection.

(1) Turn on the Multi-drop Function

Turn on the multi-drop function using setting mode/RS485 setting/multi-drop setting on the LCD display. Refer to Section 6.6 "Software Operation" (4) for details about the setting method.

(2) Setting the Network ID

The network ID is set using setting mode/RS485 setting/network ID setting on the LCD display to designate which controller connected via the multi-drop connection the computer is sending commands to.

The network ID is set as a number between 01 and 32, and must be unique for each controller connected to a computer. Refer to Section 6.6 "Software Operation" (4) for details about the setting method.

When the RS-485 interface multi-drop function is turned on, the event sending function (Refer to Section A6.5 "Events") will be disabled, regardless of the SETTINGS/RS485/EVENT SENDING menu settings on the LCD display.

A4 SERIAL COMMUNICATIONS PROTOCOL

Communications software, between the controller and customer equipment should be design according to the following specifications.

(1) Basic Message Structure

A basic transmit and receive message begins with the characters "MJ" and ends with a carriage return code (0dH: xxH means hexadecimal code) (Refer to Table A-1).

The first message to be sent is referred as the COMMAND, while the reply to the command is referred as the ANSWER.

Table A-1 Basic Structure of Commands and Answers

Character	Hex. Code	Description	Number Of Bytes
M	4d	Command header characters	2
J	4a		
0	30	Network ID	2
1	31	Multi-drop function OFF: 01 fixed Multi-drop function ON: 01 to 32	
X	xx	Command Characters	2
X	xx		
		Sub-command Characters	X
f	xx	Checksum characters (Calculation result by Section A4.7 enters it)	2
f	xx		
CR	0d	Carriage return character	1

(2) Character to Character Time-out: 0.1 sec.

Delays between characters, in the answer message, longer that 0.1 sec., shall be considered as a transmission line failure and special considerations should be made to re-send the message.

(3) Command to Answer Time-out: 1 sec.

Delays between COMMAND and ANSWER messages, longer that 1 sec., shall be considered as a transmission line failure and special considerations should be made to re-send the message.

The controller re-sends a COMMAND, if it does not receive and ANSWER within a one second period.

(4) Controller Command Send Retry Cycles: 5

If the controller does not receive and answer to a command, within one second, it will re-send the same command up to a maximum of five times.

Appendix A COMMUNICATIONS

(5) Command Transmission Specification

A command sent before an answer is sent, will be ignored by the controller, until a reply to the first command is sent. However, this does not apply after a transmission time-out occurs between command and answer (If processing is performed normally, an answer is returned within 100 msec.).

(6) Receiving Sequence

The character string from the controller is received after the COMMAND character string is sent. When the carriage return code (0dH) is received, the received character string is checked from the beginning and the portion from the initial command header "MJ" to the carriage return code received last is processed as an answer.

Initialize the receive buffer after the answer character string is acquired from the receive buffer. The read user memo (described below) may receive the same "MJ" as the command header character string in the answer character string. Therefore, interpret the character string from the first "MJ" appearing in the receive buffer to the carriage return as the answer character string.

(7) Using the Checksum Byte

Always calculate the checksum for a received character string and compare it with the checksum byte data to confirm that the character string was received correctly. Conduct error processing such as re-sending the command when a character string is received with an incorrect checksum.

Calculation Example :

In the received character string "MJ01LS97\$" (" \$" represents the carriage return code), the check sum code is represented by the last two characters: "97".

The checksum for the received character string is calculated as follows. The result shows that the received character string is correct.

	'M'	'J'	'0'	'1'	'L'	'S'		
Checksum =	4dH+	4aH+	30H+	31H+	4CH +	53H	=197H	=97H

(8) Outline of Multi-drop Communications

If the multi-drop function is turned on, set the network ID portion of a sent command to the network ID of the controller with which communication is required.

All connected controller receive the sent command, but only the controller with a network ID (set using setting mode/RS485 setting/network ID setting on the LCD display) that matches the network ID portion of the command returns an answer to the command it received.

Consequently, to acquire information from all connected controller requires repeated command/answer cycles with all controller while changing the network ID.

A5 TABLE OF COMMANDS

Table A-2 Table of Commands

Type	Command/ answer	Name	Command character string	Sub-command character string	
Operation mode	Command	Operation mode check	LS	None	
		On-line request	LN	None	
		Off-line request	LF	None	
	Answer	Local	LL	None	
		Remote	LR	None	
		RS-232C	LC	None	
RS-485		LD	None		
Operation request	Command	START operation	RT	None	
		STOP operation	RP	None	
		RESET operation	RR	None	
	Answer	Acceleration start	RA	None	
		Deceleration start	RB	None	
		Buzzer off	RZ	None	
		Failure occurred	RF	aa	*1
		Failure elimination	RC	None	
		Operation invalid	RV	None	
Run status	Command	Run status check	CS	None	
	Answer	Stop	NS	aa	*1
		Acceleration	NA	aa	*1
		Normal rotation	NN	aa	*1
		Deceleration	NB	aa	*1
		Failure-Stop	FS	aa	*1
		Failure-Free run	FF	aa	*1
		Failure-Regenerative braking	FR	aa	*1
	Failure-Deceleration	FB	aa	*1	
	Command	Read alarm list	CF	aa	*5
Answer	Send alarm list	CA	aabb	*6	
	No alarm list	CV	aa	*5	
Parameters	Command	Read parameter	PR	aa	*2
	Answer	Send parameter	PA	aabbbb	*3
		Invalid parameter number	PV	aa	*2
Event	Command	Failure occurred	EF	aa	*1
		Rotation start	ER	None	
		Rotation stop	ES	None	
		Normal rotation	EN	None	
	Answer	Event confirmation	EC	aa	*4
Timer	Command	Read timer	TR	aa	*7
		Clear timer	TC	aa	
		Write timer	TW	06aaaaa	*8
	Answer	Send timer value	TA	aabbbbccc... ccddd...dd	*9
		Invalid timer number	TV	aa	*7

Appendix A COMMUNICATIONS

Type	Command/answer	Name	Command character string	Sub-command character string	
History	Command	Read alarm history	GA	aa	*10
	Answer	Send alarm history	GB	XXX...XXX	*11
		No history data	GV	aa	*10
Settings	Command	Read settings	SR	aa	*12
		Write settings	SW	aabbbb	*13
	Answer	Send settings value	SA	aabbbb	*13
		Invalid setting number	SV	aa	*12
	Command	Read user memo	SU	None	
		Write user memo	SX	XXX...XXX	*14
	Answer	Send user memo	SF	XXX...XXX	*14
Shared answer	Answer	Invalid command	AN	None	

- *1 aa: Failure alarm codes (hexadecimal) corresponding to the protection system. Refer to Table 7-6 "Table of Alarms" and Table 7-7 "Table of Warnings" in this manual for details.
- *2 aa: Parameter number (decimal). Refer to Table A-3 "Table of Parameters".
- *3 aa: Parameter number (decimal). Refer to Table A-3 "Table of Parameters".
bbbb: Parameter value (decimal). Refer to Table A-3 "Table of Parameters".
- *4 aa: Confirm event command character string.
Send the unchanged command character string of the confirmed event command.
Example: Failure occurred → "EF"
- *5 aa: Alarm list number (decimal)
- *6 aa: Alarm list number (decimal)
bb: Alarm code (decimal) stored in the alarm list with the requested number.
Refer to Table 7-6 "Table of Alarms" and Table 7-7 "Table of Warnings" in this manual for details.
- *7 aa: Timer number (decimal). Refer to Table A-4 "Table of Timer".
- *8 06 (fixed): Timer number (decimal). Refer to Table A-4 "Table of Timer".
aaaa: Set value (decimal). Refer to Table A-4 "Table of Timer".
- *9 aa: Timer number (decimal). Refer to Table A-4 "Table of Timer".
bbbbbb: Timer value (decimal). Refer to Table A-4 "Table of Timer".
ccccccccc: Time when the timer updated (YYMMDDHHMM format. Stored as Greenwich Mean Time).
ddddddddd: Time when the timer reset (YYMMDDHHMM format. Stored as Greenwich Mean Time).
- *10 aa: History number
- *11 xxx...xxx: Refer to Table A-5 "Alarm History Data Format".
- *12 aa: Settings number (decimal). Refer to Table A-6 "Table of Settings".
- *13 aa: Settings number (decimal). Refer to Table A-6 "Table of Settings".
bbbb: Set value (decimal). Refer to Table A-6 "Table of Settings".
- *14 xxx...xxx: Any 20-character displayable character string.

Table A-3 Table of Parameters

No.	Name	Range	Description and format
01	Model identification number	0000 to 9999	The pump model connected. Example: UTM3400 → "3400"
03	Rotational speed	0000 to 5000	Rotational speed / 10 Example: 15000 rpm → "1500"
04	Motor current	0000 to 0100	Motor drive current x 10 Example: 2.3 A → "0023"
07	Temperature control function	0000 to 0002	Temperature control function setting status "0000": Temperature control function on "0001": Temperature control function off "0002": Controller has no temperature control function
09	Rotational speed (%)	0000 to 0100	Percentage of rated rotational speed. Example: 80 % → "0080"
10	Rotational speed (%)	0000 to 1000	Percentage of rated rotational speed (x10). Example: 80 % → "0800"
11	Rated rotational speed	0000 to 5000	Rated rotational speed / 10 Example: 21000 rpm → "2100"
21	Axis 1 unbalance monitor amount	0000 to 0100	Unbalance monitor value of magnetic bearing: Axis 1 Example: 3 % → "0003"
22	Axis 2 unbalance monitor amount	0000 to 0100	Unbalance monitor value of magnetic bearing: Axis 2 Example: 3 % → "0003"
26	MB sensor output X1	0000 to 0100	Sensor output monitor value of magnetic bearing: Axis X1 Example: 3 % → "0003"
27	MB sensor output Y1	0000 to 0100	Sensor output monitor value of magnetic bearing: Axis Y1 Example: 3 % → "0003"
28	MB sensor output X2	0000 to 0100	Sensor output monitor value of magnetic bearing: Axis X2 Example: 3 % → "0003"
29	MB sensor output Y2	0000 to 0100	Sensor output monitor value of magnetic bearing: Axis Y2 Example: 3 % → "0003"
30	MB sensor output Z	0000 to 0100	Sensor output monitor value of magnetic bearing: Axis Z Example: 3 % → "0003"

Table A-4 Table of Timer

No.	Name	Range	Description and format
01	Run time	00000 to 99999	Read the timer value in the "MENU MODE / INTEGRAL TIMER / RUN TIME" on the LCD display (Cannot be reset. Reset date is invalid). Example: 0 time → "00000", 99999 time → "99999"
02	Last maintenance time	00000 to 99999	Read the timer value in the "MENU MODE / INTEGRAL TIMER / LAST MAINT." on the LCD display (Can be reset). Example: 0 time → "00000", 99999 time → "99999"
03	Power failure touch-down count	00000 to 00999	Read the timer value in the "MENU MODE / INTEGRAL TIMER / POWER FAILURE" on the LCD display (Can be reset). Example: 0 count → "00000", 999 count → "00999"
04	High-speed touch-down count	00000 to 00999	Read the timer value in the "MENU MODE / INTEGRAL TIMER / MB ALARM" on the LCD display (Can be reset). Example: 0 count → "00000", 999 count → "00999"
05	MB warning counter	00000 to 00999	Read the timer value in the "MENU MODE / INTEGRAL TIMER / MB WARNING" on the LCD display (Can be reset). Example: 0 count → "00000", 999 count → "00999"
06	Maintenance call time	00000 to 99999	Read or change the timer value in the "MENU MODE / INTEGRAL TIMER / MAINT.CALL" on the LCD display. Example: 0 time (function is disabled) → "00000", 99999 time → "99999"

Table A-5 Alarm History Data Format

	Item	Number of bytes	Data	Comments
1	History number	2	01 to 99	History number designated by the command.
2	Time	10	YYMMDDHHMM	Time when the failure occurred (stored as Greenwich Mean Time) YY: year, MM: month, DD: day, HH: hour, MM: minutes
3	Alarm number	2	00 to 99	Alarm number of the failure that occurred. Refer to Table 7-6 "Table of Alarms" and Table 7-7 "Table of Warnings" in this manual for details.
4	Run status	2	NS, NA, NN...	Run status when the failure occurred. Data is identical to CS command answer.
5	Rotational speed	4	0000 to 0100	Speed when the failure occurred. Format is identical to 09 in Table A-3.
6	Motor current	4	0000 to 0150	Motor current in the event of a fault. The format is the same as No.04 in Table A-3.
7	Pump temperature	2		Not relevant for this controller
8	Temperature control function	2	00, 01, 02	Temperature control function when the failure occurred. Format is equivalent to last 2 characters of 07 in Table A-3.
9	Temperature control set temperature	2		Not relevant for this controller
10	Axis 1 unbalance monitor amount	4	0000 to 0100	Unbalance monitor value of magnetic bearing when a fault occurs: Axis 1 Format is the same as No.21 in Table A-3.
11	Axis 2 unbalance monitor amount	4	0000 to 0100	Unbalance monitor value of magnetic bearing when a fault occurs: Axis 2 Format is the same as No.22 in Table A-3.
12	MB sensor output X1	4	0000 to 0100	Sensor output monitor value of magnetic bearing when a fault occurs: Axis X1 Format is the same as No.26 in Table A-3.
13	MB sensor output Y1	4	0000 to 0100	Sensor output monitor value of magnetic bearing when a fault occurs: Axis Y1 Format is the same as No.27 in Table A-3.
14	MB sensor output X2	4	0000 to 0100	Sensor output monitor value of magnetic bearing when a fault occurs: Axis X2 Format is the same as No.28 in Table A-3.
15	MB sensor output Y2	4	0000 to 0100	Sensor output monitor value of magnetic bearing when a fault occurs: Axis Y2 Format is the same as No.29 in Table A-3.
16	MB sensor output Z	4	0000 to 0100	Sensor output monitor value of magnetic bearing when a fault occurs: Axis Z Format is the same as No.30 in Table A-3.
17	Operation time	6	000000 to 099999	Operation time when a fault occurs. Format is the same as No.01 in Table A-4.

Table A-6 Table of Settings

No.	Name	Range	Description and format
01	Temperature control on/off	0000 / 0001	Read or change the set values in the "MENU / SETTINGS / TEMP.CONTORL / TEMP.CONTROL" on the LCD display. "0000": Temperature control function on "0001": Temperature control function off (Valid only for a controller with a temperature control function)
02	Speed display format	0000 to 0002	Read or change the set values in the "MENU / SETTINGS / ROT.SPEED / DISPLAY" on the LCD display. "0000": %, "0001": rpm, "0002": rps
03	Rotational speed	0000 / 0001	Read or change the set values in the "MENU / SETTINGS / ROT.SPEED / SPEED" on the LCD display. "0000": NORMAL, "0001": LOW SPEED
04	Low speed value	0025 to 0100	Read or change the set values in the "MENU / SETTINGS / ROT.SPEED / LOW SPEED" on the LCD display. Example: 25 % → "0025", 100 % → "0100"
05	"ALARM" signal operation setting	0000 / 0001	Read or change the set values in the "MENU / SETTINGS / REMOTE SIGNAL MODE / ALARM" on the LCD display. "0000": SEMI-E74, "0001": EI-03
06	"REMOTE" signal operation setting	0000 / 0001	Read or change the set values in the "MENU / SETTINGS / REMOTE SIGNAL MODE / REMOTE" on the LCD display. "0000": SEMI-E74, "0001": EI-03
07	"STOP" signal operation setting	0000 / 0001	Read or change the set values in the "MENU / SETTINGS / REMOTE SIGNAL MODE / STOP" on the LCD display. "0000": REMOTE ONLY, "0001": REMOTE&RSXXX
08	Low rotation speed	0250 to 1000	Read or change the set values in the "MENU / SETTINGS / ROT.SPEED / LOW SPEED" on the LCD display. Example: 25.0 % → "0250", 99.9 % → "0999"
10	Warning output setting	0000 / 0001	Read or change the set values in the "MENU / SETTINGS / WARNING DISPLAY" on the LCD display. "0000": ON, "0001": OFF
11	Power failure detect setting	0000 / 0001	Read or change the set values in the "MENU / SETTINGS / PF DETECT" on the LCD display. "0000": 2 sec, "0001": 1 sec

A6 COMMAND DESCRIPTION

A6.1 Operation Mode

Commands	LS	Operation mode check Enables operation mode verification (LOCAL / REMOTE / RS-232C / RS-485) Action: Controller returns an ANSWER showing present operation mode.
	LN	ON-LINE request If the current operation mode is REMOTE, the operation mode is shifted to RS-232C or RS-485. This command is ineffective in other operation modes. Action: Controller returns an ANSWER showing the present operation mode.
	LF	OFF-LINE request If the current operation mode is RS-232C or RS-485, the operation mode is shifted to REMOTE. This command is ineffective in other operation modes. Action: Controller returns an ANSWER showing the present operation mode.
Answers	LL	Operation mode LOCAL This answer is returned when the operation mode is LOCAL. The operation mode can also be shifted to LOCAL mode by the front panel REMOTE/LOCAL selection switch.
	LR	Operation mode REMOTE This answer is returned when the operation mode is REMOTE. The operation mode can also be shifted to REMOTE mode by the front panel REMOTE/LOCAL selection switch or when in the RS-232C or RS-485 operation mode by the "OFF-LINE" request command.
	LC	Operation mode RS-232C This answer is returned when the operation mode is RS-232C. The operation mode is shifted to RS-232C when the "ON-LINE" request command is sending via RS-232C in the remote operation mode.
	LD	Operation mode RS-485 This answer is returned when the operation mode is RS-485. The operation mode is shifted to RS-485 when the "ON-LINE" request command is sending via RS-485 in the remote operation mode.

A6.2 Operation

Commands	RT	<p>START Operation This command is the equivalent of pushing the front panel START switch. Action: The turbo molecular pump starts accelerating and sends the "Acceleration Start" answer.</p>
	RP	<p>STOP Operation This command is the equivalent of pushing the front panel STOP switch. Action: The turbo molecular pump starts decelerating and sends the "Deceleration Start" answer.</p>
	RR	<p>RESET Operation This command is the equivalent of pushing the front panel RESET switch. Action: This command is effective against failures. This command resets the alarm buzzer sound and returns the "Buzzer Off" answer. If the buzzer is already off, this command resets the ALARM. If the cause of the alarm is eliminated after resetting, the "Failure Elimination" answer will be returned, else the buzzer will sound again and the "Failure occurrence" Answer is sent back.</p>
Answers	RA	<p>Acceleration Start This answer is returned by the controller after the acceleration is started on a START operation.</p>
	RB	<p>Deceleration Start This answer is returned by the controller after the deceleration is started on a STOP operation.</p>
	RZ	<p>Buzzer Off This answer is returned by the controller after the buzzer is turned off on a RESET operation.</p>
	RC	<p>Failure elimination This answer is returned by the controller after the failure cause is removed after the controller is reset on a RESET operation.</p>
	RF	<p>Failure Occurrence This answer is returned by the controller if the failure cause is not removed after the controller is reset on a RESET operation. The alarm code of the failure that has not been eliminated is returned as a 2-character sub-command.</p>
	RV	<p>Operation invalid This answer is returned if the operation is invalid (START operation command sent during acceleration) or if the operation mode differs from the port that sent the command (operation mode is RS-485 but operation command was sent from the RS-232C port).</p>

A6.3 Run Status

Commands	CS	Run Status Check This command requests the current controller status.
Answers	NS	Stop This answer is returned when the pump stops. Equivalent to the monitor mode/STOP run status on the LCD display. For a normal status, "00" is returned as the sub-command. If a warning has occurred, the 2-character alarm code is returned as the sub-command.
	NA	Acceleration This answer is returned during pump acceleration. Equivalent to the monitor mode/ACC. run status on the LCD display. For a normal status, "00" is returned as the sub-command. If a warning has occurred, the 2-character alarm code is returned as the sub-command.
	NN	Normal rotation This answer is returned during normal pump rotation. Equivalent to the monitor mode/ NORMAL run status on the LCD display. For a normal status, "00" is returned as the sub-command. If a warning has occurred, the 2-character alarm code is returned as the sub-command.
	NB	Deceleration This answer is returned during pump deceleration. Equivalent to the monitor mode/BRAKE run status on the LCD display. For a normal status, "00" is returned as the sub-command. If a warning has occurred, the 2-character alarm code is returned as the sub-command.
	FS	Failure-Stop This answer is returned when the pump is stopped after a failure occurs. Equivalent to the monitor mode/E-STOP run status on the LCD display. The 2-character alarm code is returned as the sub-command.
	FF	Failure-Free run This answer is returned when the pump is free-running (neither accelerating nor decelerating) after a failure occurs. Equivalent to the monitor mode/E-IDLE run status on the LCD display. The 2-character alarm code is returned as the sub-command.
	FR	Failure-Regenerative braking This answer is returned when the pump is regenerative braking after a failure occurs. Equivalent to the monitor mode/E-BRAKE run status on the LCD display. The 2-character alarm code is returned as the sub-command.
	FB	Failure-Deceleration This answer is returned when the pump is decelerating after a failure occurs. Equivalent to the monitor mode/E-BRAKE run status on the LCD display. The 2-character alarm code is returned as the sub-command.
Commands	CF	Read alarm list Reads the alarm that occurred for a designated alarm list number. The alarm list numbers are equivalent to the sequence displayed on the LCD in the LCD display alarm mode. To check all the current failures, the sub-command alarm list number is increased sequentially from 01 until the answer CV is returned.
Answers	CA	Send alarm list Returns the alarm code corresponding to the requested alarm list number. The sub-command returns a 2-character alarm list number and a 2-character alarm code.
	CV	No alarm list This answer is returned if no alarm corresponds to the requested alarm list number. The sub-command returns a 2-character alarm list number.

A6.4 Parameters

Commands	PR	Read parameter Reads the parameter value for a designated parameter number. Sends the 2-character parameter number as the sub-command. Refer to Table A-3 "Table of Parameters" for parameter number.
Answers	PA	Send parameter Returns the parameter value for the designated parameter number. The 2-character parameter number + 4-character parameter value is returned as the sub-command.
	PV	Invalid parameter number This answer is returned if the designated parameter number is invalid. Returns the 2-character parameter number as the sub-command.

A6.5 Events

For the event functions only, commands are sent from the controller to the connected computer, and the answers are sent from the computer to the controller.

This function can also be disabled by setting the SETTINGS/RS232C/EVENT SENDING or SETTINGS/RS485/EVENT SENDING menu setting to OFF on the LCD display.

This function will be disabled automatically if the RS485 multi-drop function is enabled.

In the default status, command EF is transmitted when either an alarm or warning occurs.

However, if the warning output setting is OFF in the menu mode SETTINGS/WARNING DISPLAY item on the LCD, command EF is not transmitted when warnings of alarm codes 86 to 98 (Table 7-7 "Table of Warnings") occur.

Commands	EF	Failure occurred Sent to the connected computer when an failure occurs. The 2-character alarm code for the failure is sent as the sub-command.
	ER	Start rotation Sent to the connected computer when pump rotation starts. Equivalent to the ROTATION lamp lighting.
	ES	Stop rotation Sent to the connected computer when pump rotation stops. Equivalent to the ROTATION lamp going out.
	EN	Normal speed Sent to the connected computer when the normal rotation speed is achieved. Equivalent to the NORMAL SPEED lamp lighting.
Answers	EC	Confirm event Return this answer to the controller when an event is received from the controller. The controller sends the command up to five times at one-second intervals until it receives the confirm event answer. Send the 2-character command character string for the received event command as a sub-command.

A6.6 Timer

Commands	TR	Read timer Reads the timer value for a designated timer number. Sends the 2-character timer number as the sub-command. Refer to Table A-4 "Table of Timer" for timer number.
	TC	Clear timer Clears the timer value for a designated timer number. Sends the 2-character timer number as the sub-command.
	TW	Write timer Overwrites the set value for a maintenance call timer. Sends the 2-character settings number + 5-character set value data as the sub-command.
Answers	TA	Send timer value Returns the timer value for the designated timer number. The 2-character timer number + 5-character timer value is returned as the sub-command.
	TV	Invalid timer number This answer is returned if the designated timer number is invalid. Returns the 2-character timer number as the sub-command.

A6.7 History

Commands	GA	Read alarm history Reads the alarm history for a designated alarm history number. Sends the 2-character alarm history number as the sub-command.
Answers	GB	Send alarm history Returns the alarm history for the designated alarm history number. The 64-character alarm history data is returned as the sub-command in the format shown in Table A-5 "Alarm History Data Format".
	GV	No history data This answer is returned if no alarm history data corresponds to the designated alarm history number. Returns the 2-character alarm history number as the sub-command.

A6.8 Settings

Commands	SR	Read settings Reads the set value for a designated settings number. Sends the 2-character settings number as the sub-command. Refer to Table A-6 "Table of Settings" for setting number.
	SW	Write settings Overwrites the set value for a designated settings number. Sends the 2-character settings number + 4-character set value data as the sub-command. Refer to Table A-6 "Table of Settings" for setting number and set value.
Answers	SA	Send settings value Returns the set value for the designated settings number. The 2-character settings number + 4-character set value is returned as the sub-command.
	SV	Invalid setting number This answer is returned if the designated settings number is invalid. Returns the 2-character settings number as the sub-command.
Commands	SU	Read user memo Reads the character string in the user memo.
	SX	Write user memo Overwrites the character string in the user memo. Sends the 20 characters to set in the user memo as the sub-command. If less than 20 characters are set, the remaining characters are filled with spaces. Be sure to always send 20 characters.
Answers	SF	Send user memo Returns as a sub-command the set user memo character string or the 20-character user memo character string overwritten by the SX command.

A6.9 Shared Answer

Answers	AN	Invalid Command Answer returned by the controller after it receives an invalid command.
---------	----	--

A7 RS-232C COMMANDS / ANSWERS

(SEND AND RECEIVE Examples)

Table A-7 RS-232C COMMANDS / ANSWERS (SEND AND RECEIVE Examples)

Type	Computer (Host) *1	Send/Receive *2	Controller	Description	Remarks	
Operation Mode	MJ01LS97\	→		Operation Mode Check		
		←	MJ01LL90\	LOCAL		
			MJ01LR96\	REMOTE		
			MJ01LC87\	RS-232C		
			MJ01LD88\	RS-485		
		MJ01LN92\	→		ON-LINE Request	ON-LINE request from RS-232C communication port
		←	MJ01LC87\	Operation Mode Change	Operation mode changed to RS-232C ON-LINE	
			MJ01LD88\	Invalid Request	When in RS-485 mode	
			MJ01LL90\	Invalid Request	When in LOCAL mode	
		MJ01LF8A\	→		OFF-LINE Request	OFF-LINE request from RS-232C communication port
		←	MJ01LR96\	Operation Mode Change	Operation mode changed to REMOTE	
			MJ01LD88\	Invalid Request	When in RS-485 mode	
	MJ01LL90\		Invalid Request	When in LOCAL mode		
TMP Operation	MJ01RT9E\	→		START Operation	START operation from RS-232C communication port	
		←	MJ01RA8B\	Acceleration Start		
			MJ01RVA0\	Ineffective Operation	When START operation is ineffective or operation mode is not RS-232C	
	MJ01RP9A\	→		STOP Operation	STOP operation from RS-232C communication port	
		←	MJ01RB8C\	Deceleration Start		
			MJ01RVA0\	Ineffective Operation	When STOP operation is ineffective or operation mode is not RS-232C	
	MJ01RR9C\	→		RESET Operation	RESET operation from RS-232C communication port	
		←	MJ01RZA4\	Buzzer Off	When a buzzer sounded	
			MJ01 RF50F5\	Failure Occurrence	When the failure was not eliminated.	
			MJ01RC8D\	Failure Eliminated	When the failure was eliminated.	
	MJ01RVA0\		Ineffective Operation	When RESET operation is ineffective or operation mode is not RS-232C		

Type	Computer (Host) *1	Send/Receive *2	Controller	Description	Remarks
Run Status	MJ01CS8E\	→		Run Status Check	
		←	MJ01 NS00F9\	Stop	
			MJ01 NA00E7\	Acceleration	
			MJ01 NB00E8\	Deceleration	
			MJ01NN00F4\	Normal Rotation	
			MJ01 FSI C05\	Failure Stop	LCD: "TMP:CAN NOT START"
			MJ01 FF32E9\	Failure Idle	LCD: "EI:DC-DC OVERTEMP"
			MJ01 FR15F6\	Failure Regeneration	LCD: "POWER FAILURE"
			MJ01 FB60E6\	Failure Deceleration	LCD: "MB:VIBRATION 1 Z"
		MJ01 CF01 E2\	→		Read Alarm List
		←	MJ01 CA011543\	Send Alarm List	Power failure occurred
Parameter	MJ01PR03FD\	→		Read Parameter	Parameter 03 (rotational speed)
		←	MJ01 PA032700B5\	Send Parameter	Data = 2700 (27000 rpm)
	MJ01 PR1500\	→		Read parameter	Parameter 10 (invalid number)
		←	MJ01 PV1504\	Invalid parameter number	
Event		←	MJ01 EF15E9\	Failure Occurrence	Power failure occurred.
	MJ01ECEFOB\	→		Event Confirmation	
		←	MJ01ER8F\	Rotation Start	
	MJ01ECER17\	→		Event Confirmation	
		←	MJ01ES90\	Rotation Stop	
	MJ01ECES18\	→		Event Confirmation	
		←	MJ01EN8B\	Normal Rotation	
Timer	MJ01TR01 FF\	→		Read Timer	Timer 01 (Run time)
		←	MJ01TA01001350304051500000000000B9\	Send Timer	Timer 01 = 135 (135 hours) Last update: 2003/4/5 15:00 Last reset: (invalid)
	MJ01TC03F2\	→		Clear Timer	Clear timer 03 (Number of power failure touch-downs).
		←	MJ01TA030000003040515000304051500C4\	Send Timer	Sets timer 03 = 0 to date/time cleared. Sets reset date/time to date/time when clear command was sent.
	MJ06TW06050003\	→		Write Timer	Timer 06 = 5000 Value set. (Maintenance call time)
		←	MJ01TA060500003040515000304051500CC\	Send Timer	Sets timer 06 = 5000 to date/time updated. Sets reset date/time to date/time when write command was sent.

Type	Computer (Host) *1	Send/Receive *2	Controller	Description	Remarks
History	MJ01GA01E\	→		Read Alarm History	History 01
		←	MJ01GB0103 0401120015N N0100001000 02750004000 60003000300 05000500020 0120098\	Send Alarm History	History: 01 Date & time: 2003/04/01 12:00 Alarm: power failure Status: normal rotation Rotational speed: 100 % Motor current: 1.0 A Pump temperature: 00 degrees C. (*3) Temperature control function: Controller has no temperature control function Temperature control set temperature: 75 degrees C. (*3) Unbalance monitor Axis1: 4 %, Axis2: 6 % MB sensor output X1: 3 %, Y1: 3 %, X2: 5 %, Y2: 5 %, Z: 2 % Runtime: 1200 hours
	MJ01GA10E1\	→		Read Alarm History	History 10
		←	MJ01GV10F6\	No History Data	Less than 10 alarm data
Setting	MJ01SR02FF\	→		Read Settings	Settings number 02
		←	MJ01SA0200 00AE\	Send Settings Value	Settings number 02=0 →Speed display: %
	MJ01SW02000 1C5\	→		Write Settings	Overwrite settings number 02 = 1
		←	MJ01SA0200 01AF\	Send Settings Value	Settings number 02=1 →Speed display: rpm
Others	MJ01AA7A\	→		Undefined Command	When undefined command is received
		←	MJ01AN87\	Invalid Command	
	MJ01LS20\	→		Operation Mode Check	When command is correct, but checksum is not.
		←	MJ01AN87\	Invalid Command	

*1: "\ " represents a carriage return code (0dH).

*2: → From computer to controller.

← From controller to computer.

*3: Invalid for a controller without a pump temperature control function, but data is set.

A8 RELATION OF LOCAL MODE TO REMOTE MODE OPERATIONS

- (1) Input of front panel switch is only effective when REMOTE lamp is in "LOCAL" mode (REMOTE lamp is OFF).
- (2) When the REMOTE lamp is in "REMOTE" mode (REMOTE lamp is ON), "REMOTE" input signal only is effective under initial status.
- (3) When the REMOTE lamp is in "REMOTE" mode (REMOTE lamp is ON),
 - a. The operation mode is shifted to RS-232C ON-LINE in response to ON-LINE request of operation mode command from RS-232C communication port, only operation by the operation request command from computer is effective.
 - b. The operation mode is shifted to RS-485 ON-LINE in response to ON-LINE request of operation mode command from RS-485 communication port, only operation by the operation request command from computer is effective.
- (4) RESET switch input and "RESET" signals are all-time effective.
- (5) When the selection switch is shifted to "LOCAL" under ON-LINE operation mode, the operation mode is force-shifted to LOCAL.
- (6) Commands other than operation commands are all-time effective, and the controller sends back an answer message to computer. In addition, event commands are all-time sent against event occurrence.

A9 TROUBLESHOOTING

A9.1 No Message can Transmit and Receive

- (1) Start the pump in LOCAL mode and check if the event command of Rotation start can be received in the timing at which ROTATION lamp lights.
 - a. Could be received >> check if command from connected computer can be received or not, using another computer, etc.
 - b. A nonsensical character string was received >> Go to Section A9.2.
 - c. Not receivable >> (2)
- (2) Check the connection of RS-232C cable in reference to Section A2 "INTERFACE SPECIFICATION".

Check the polarity of RS-485 interface, because there is the case that polarity is reverse.
- (3) Check the transmission specification of RS-232C at computer side.

A9.2 Sending and Receiving are Done, But Receivable Messages are Invalid

- (1) Check the transmission rate of the controller and computer.

A9.3 Characters Get Disordered from Time to Time, Then Resulting in CHECKSUM Error

- (1) Remove the cable from equipment as noise source if it runs near it.
- (2) When the cable in use is not a shield cable, replace it with the latter cable.

When shield cable is used, be sure to check that it is connected to the frame gland of the connected computer.

Use twisted pair cable when RS-485 is used.
- (3) When 10 m or longer cable is used, replace it with another cable as short as possible.
- (4) Make the transmission rate smaller unless there is problem in application program.

株式会社アルバック
規格品事業部

<https://showcase.ulvac.co.jp/ja/>

製品情報・サービス拠点・お問い合わせはこちらから



showcase.ulvac.co.jp

株式会社アルバック
規格品事業部 営業部 東日本営業課
〒253-8543
神奈川県茅ヶ崎市萩園 2 5 0 0
TEL:0467-89-2416

株式会社アルバック
規格品事業部 営業部 西日本営業課
〒532-0003
大阪府大阪市淀川区宮原 3 - 3 - 3 1 上村ニッセイビル5F
TEL:06-6397-2286

ULVAC ,Inc.
Components Division

<https://showcase.ulvac.co.jp/en/>

Please contact us for products, Service Base or other Inquiries from here.



showcase.ulvac.co.jp/en

ULVAC, Inc.
Components Division
2500 Hagisono, Chigasaki, Kanagawa, 253-8543, Japan
TEL: +81-467-89-2261