

---

# **INSTRUCTION MANUAL**

## **Turbo Molecular Pump UTM-MS Series**

Model

UTM300A-MS

UTM400A-MS

Before using this product, be sure to read this operation manual.

Keep this manual with care to use at any time.

**ULVAC KIKO, Inc.**

---

No Text

## Introduction

Thank you for choosing the ULVAC KIKO Turbo Molecular Pump.

Please read the instruction manual carefully before using turbo molecular pump, and save the instruction manual for future reference.

## Copyrights and Disclaimers

---

This document is copyrighted by ULVAC KIKO, Inc. Please refrain from reproducing or copying part or all of this document without permission from ULVAC KIKO.

In an effort to improve the product, this document may be revised in the future without notice.

Every effort has been made to prepare an accurate and complete manual, but if an error or omission should be discovered, revisions might not be possible immediately.

ULVAC KIKO does not take responsibility for any effects that may result from the use of this manual.

---

## Precautions for Safe Operation

---

The instruction manual's nomenclature for warnings and precautions complies with the following safety warning symbols.

**WARNING**

Indicates a potentially hazardous situation which, if not avoided, could result in serious injury or possibly death.

**CAUTION**

Indicates a potentially hazardous situation which, if not avoided, may result in minor to moderate injury or equipment damage.

**NOTICE**

Emphasizes additional information that is provided to ensure the proper use of this product.

---

**WARNING**

Turbo molecular pump repair and/or controller repair can be very hazardous. Only trained technicians who are authorized by ULVAC KIKO may do service of products.

**WARNING**

Neither overhaul nor modify the pump proper and controller without admission. Doing so would impair safety of the pump proper, or cause injury by electrical shock.

**WARNING**

Decisions on system compatibility should be made by the system designer or the person deciding the specifications after conducting tests as necessary. The responsibility for guaranteeing the expected performance and safety of the system lies with the person who decides system compatibility.

---

**WARNING**

Do not operate the turbo molecular pump until safety is confirmed.

- The rotor assembly of the turbo molecular pump rotates at high speed. Large rapid shutdown torque should be generated when abnormality occurs in the pump by any chance. Incidental accident will cause the pump to drop out and to make a catastrophe if the pump is fixed by insufficient method.
  - The method to fix the pump is different depending on the pump model and the size of inlet flange of the pump.
  - Host equipment should be fixed to the floor so as not to move. Host equipment should be designed to have enough margins in strength, in preparation for an emergency accident.
- 
- 

**WARNING**

Ensure that no oil mist or hazardous substances are present in process line as safe ducting procedure when turbo molecular pump is installed to host equipment.

---

---

**WARNING**

Do not remove or do maintenance the turbo molecular pump, before safety has been confirmed.

- Improper turbo molecular pump use may be hazardous to operator's health in applications not recommended or approved by ULVAC KIKO. In the event removal of the turbo molecular pump from an application is required, full protective measures including purging of the turbo molecular pump with an inert gas and/or apparel are recommended when the turbo molecular pump has been used in applications that required the use of corrosive, reactive, stimulative, or toxic gasses.
  - Please take an adequate safety precaution based on the result of risk assessment of explosion, fire, corrosion, and toxicity, etc. that depends on process gasses.
  - Please execute the maintenance task of the turbo molecular pump after shutting power off by following proper procedure and confirming that the rotor has stopped completely.
- 
-

### **WARNING**

If the equipment is used in a manner not specified by the manufacturer, the protection provided by the equipment may be impaired.

---

---

### **CAUTION**

After having operated the turbo molecular pump for evacuation of corrosive gas, keep the pump internal as vacuumed even after shutdown. Inflow of water content in the air to the pump internal would cause rapid corrosion trouble of the pump internals. The pump corrosion may result in damaging the vacuum vessel interior and other units, causing pressure fluctuation by stopping the pump and dispersal of parts.

---

---

### **CAUTION**

Avoid to install the pump at the following places.

- (1) Place where the pump is inevitably exposed to significant vibration and impact.
- (2) Unstable place.
- (3) Place where the pump is inevitably exposed to magnetic field and radioactive ray.

The pump proper is a precision machine. Be careful not to apply abnormal vibration, shock/ impact to it during transportation. This pump is not connected to ground. Please provide PE (Protective earth) connection to the chassis of pump in final application. This pump is not an explosion-proof product. This pump is not intended to be used in a potentially explosive atmosphere.

---

---

### **CAUTION**

The pump surface may get hot, there are risk of burn.  
Prevent the installation, operation, maintenance, and service personnel from contacting the pump surface easily in all tasks that they are intended to perform.

---

---

**CAUTION**

When pump is removed from a equipment, drain the water from water pipe. If remained water leak from water pipe, pump body will be corroded.

After the water drained, shut water pipe by the cap which is attached at shipment.

---

---

**CAUTION**

The following "CAUTIONS" are to prevent operation anomalies.

**○ Operating Precautions**

- (1) Do not interrupt the electrical power operating the turbo molecular pump while the turbo molecular pump is in operation.
  - (2) Do not connect or disconnect the turbo molecular pump control cable during the time the controller is "ON".
  - (3) Protect the pump from any and all types of impact during operation.
  - (4) Do not operate any equipment (i.e. drill motor, welding machine, etc.) that produces electro-magnetic pollution, noise, etc., in the immediate proximity of an operating turbo molecular pumping system (pump, controller, cables, etc.).
  - (5) This turbo molecular pump is not approved for use in applications exhausting process gas containing gallium (Ga, e.g., triethyl gallium, etc.).
  - (6) Plasmas may cause the pump rotor to discharge electrically thus damaging the electrical components.
  - (7) Be sure to use the chemical type pumps to exhaust of gas which contain chlorine, or fluorine.
  - (8) When using the variable speed function to change the pump rotation rate, use a rotation rate that does not cause resonance with other devices installed at the site.
  - (9) Be careful to prevent a rapid pressure rise or air rush during operation.
- 
-

## ○ Explanation of Label



### (1) HOT SURFACE Label

Risk of burn. Keep off from touching surface of the pump as it is heated.

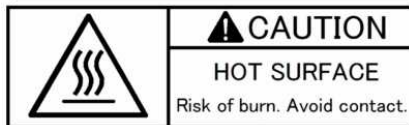

### (2) INSTALL PUMP Label

Incidental accident will cause the pump to drop out and to make a catastrophe if the pump is fixed by insufficient method.

Fix the pump to host equipment according to Section 5.1.2 "Installation of the Pump".



### (3) SECURITY Seal

This label certifies that the product was made or maintained by ULVAC KIKO or by ULVAC KIKO authorized facility.

In case "this label is removed" or "there is a mark showing once this label has been removed", ULVAC KIKO warranty shall not be applied to the product.



## ○ Location of Label

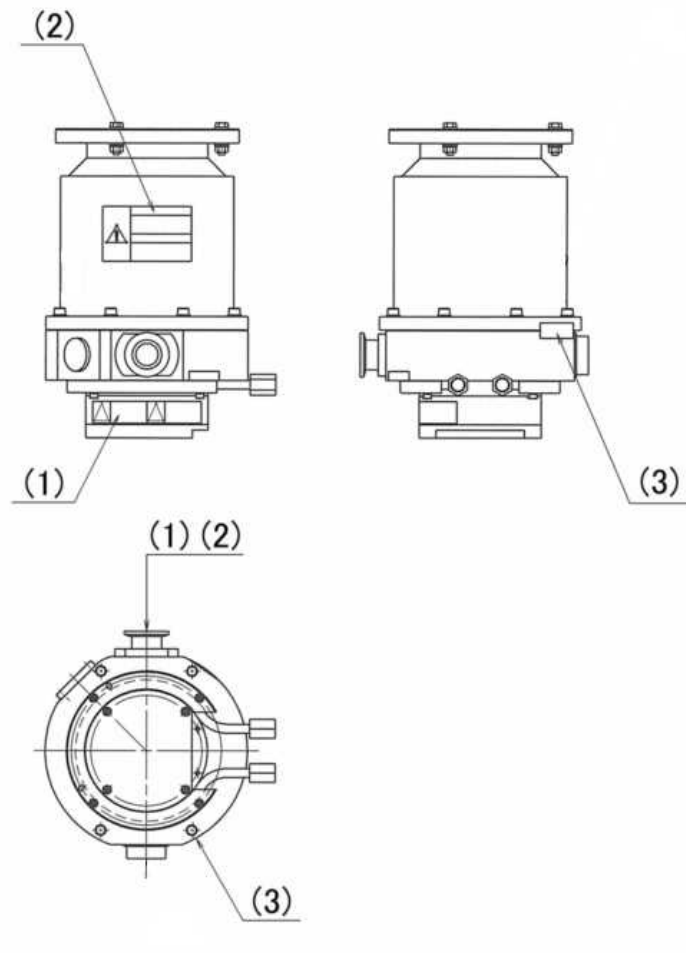

## ○ Installation Precautions

Do not apply abnormal loads to the turbo molecular pump control cable plug and/or connector. Abnormal loads may cause cable disconnection.

(1) Do not pull the turbo molecular pump control cable by the connector or plug.



(2) Do not allow any electrical cables to be in tension or to have very tight bending radii.



(3) Unbend the turbo molecular pump cable not to make any kink during connection.



## ○ Part Replacement

The lifetime of parts are specified as below.

The request for changing parts exceeding the estimated lifetime should be made to ULVAC KIKO or an approved service company in order for safety and adequate performance of the pump and controller.

**Table 1 Estimated Part Life**

Part list	Estimated part life
Cooling fan	5 years

## ○ Air Cooled Turbo Molecular Pump

For the air cooled turbo molecular pumps, it is necessary to clean the cooling fan periodically because of the cooling fan collecting dust, debris, etc. ULVAC KIKO recommends removal of the cooling fan for all methods of cleaning (compressed air, etc.) to prevent the particles, cleaning debris, from accumulating in or on the turbo molecular pump. Please refer to Fig. 1 how to change fan.

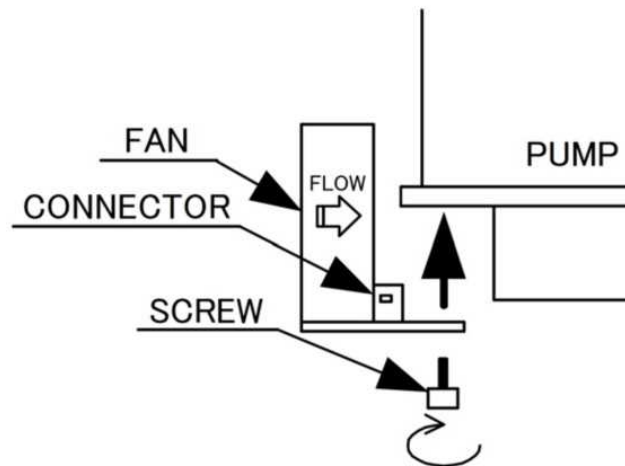

**Fig. 1 How to Change the Cooling Fan Unit**

No Text

## Table of contents

### Introduction

---

Copyrights and Disclaimers . . . . .	i
Precautions for Safe Operation . . . . .	ii
○ Operating Precautions . . . . .	v
○ Explanation of Label . . . . .	vi
○ Location of Label . . . . .	vii
○ Installation Precautions . . . . .	viii
○ Part Replacement . . . . .	viii
○ Air Cooled Turbo Molecular Pump . . . . .	ix
Table of contents . . . . .	xi

### Section 1 OUTLINE AND DESCRIPTIONS

---

1.1 Outline . . . . .	2
1.2 Descriptions. . . . .	3
1.2.1 Outside Drawing . . . . .	3
1.2.2 Standard Accessories . . . . .	7

### Section 2 IDENTIFICATION AND FUNCTION

---

2.1 Pump Main Unit . . . . .	10
------------------------------	----

**Section 3 CONSTRUCTION AND PRINCIPLE**

---

3.1 Pump Construction . . . . .12  
3.2 Principle of Turbo Molecular Pumping . . . . .12

**Section 4 SPECIFICATIONS**

---

4.1 Standard Specifications for Pump Unit. . . . .16

**Section 5 INSTALLATION**

---

5.1 Installation . . . . .20  
5.1.1 Pump Mounting Direction . . . . . 20  
5.1.2 Installation of the Pump . . . . . 21  
5.1.3 Example of Piping Connection. . . . . 25  
5.1.4 Center of Gravity of the Pump . . . . .26  
5.2 Connection of the Pump to the controller . . . . .27  
5.3 Interlock for Vacuum System . . . . .28  
5.4 Notes on Transportation. . . . .28

**Section 6 OPERATION**

---

6.1 Outline . . . . .30  
6.1.1 Introduction . . . . . 30  
6.2 Start-up Preparation . . . . .31  
6.2.1 Start-up Preparation. . . . . 31  
6.3 Start-up . . . . .31  
6.3.1 Start-up Sequence . . . . . 31  
6.4 Shutting Down . . . . .32  
6.5 Baking Operation. . . . .33

## Section 7 GAS PURGE

---

## Section 8 TURBO MOLECULAR PUMP RECONDITION

---

8.1	Recommended Maintenance Intervals. . . . .	38
8.2	Turbo Molecular Pump Decontamination. . . . .	39
8.3	Touch-down Bearing Replacement . . . . .	39
8.4	Check of the Rotor Blades. . . . .	39
8.5	Turbo Molecular Pump Return Request . . . . .	40

## Section 9 TROUBLESHOOTING

---

9.1	Vacuum Pressure Rise. . . . .	44
9.2	Abnormal Noise and/or Vibration . . . . .	44

No Text



# OUTLINE AND DESCRIPTIONS



- 1.1 Outline
- 1.2 Descriptions
  - 1.2.1 Outside Drawing
  - 1.2.2 Standard Accessories

# 1.1 Outline

The turbo molecular pump is a vacuum pump. The turbo molecular pump is used with a backing vacuum pump to create a high vacuum in a vacuum chamber.

Typical Applications; Semiconductor equipments,  
Industrial equipments,  
R&D applications,  
The other ultra high vacuum applications.

The turbo molecular pump (one standard set) consists of the following items.

- Pump Unit                    1 pc
- Controller                    1 pc
- Control Cable                1 pc
- Fan Cable                    1 pc (for Air cooled type)
- Standard Accessories      1 Set

This instruction manual explains the operation of the pump unit. For more detailed instructions regarding the controller, please refer to the controller Instruction Manual.

# 1.2 Descriptions

## 1.2.1 Outside Drawing

### 1.2.1.1 Outside Drawing of UTM300A-MS series

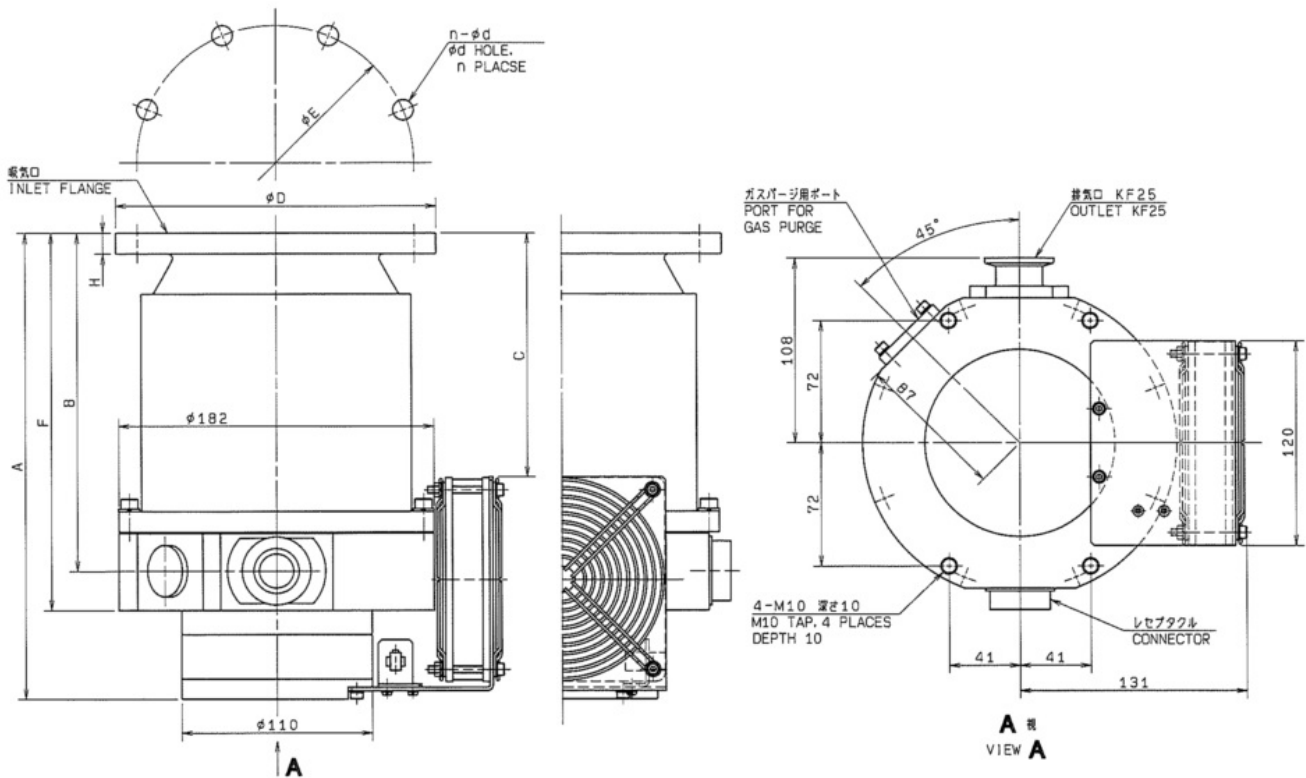

Inlet flange	A	B	C	$\phi D$	$\phi E$	n- $\phi d$	F	H
VG100	272	197	142	$\phi 185$	$\phi 160$	8- $\phi 12$	220	12
ICF152	279	204	149	$\phi 152$	$\phi 130.3$	16- $\phi 8.4$	227	20

Fig.1-1 UTM300A-MS (Air cooled)

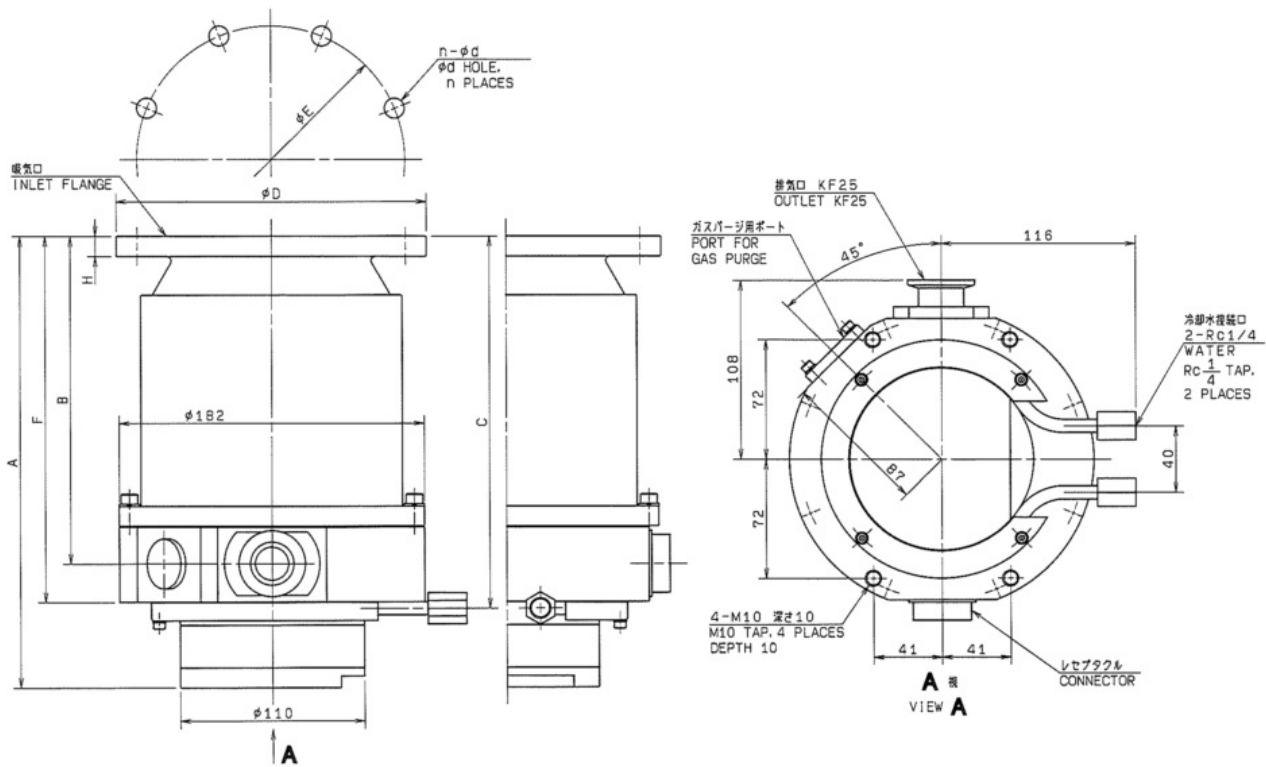

Inlet flange	A	B	C	$\phi D$	$\phi E$	$n-\phi d$	F	H
VG100	272	197	224	$\phi 185$	$\phi 160$	8- $\phi 12$	220	12
ICF152	279	204	231	$\phi 152$	$\phi 130.3$	16- $\phi 8.4$	227	20

**Fig.1-2 UTM300A-MS (Water cooled)**

1.2.1.2 Outside Drawing of UTM400A-MS series

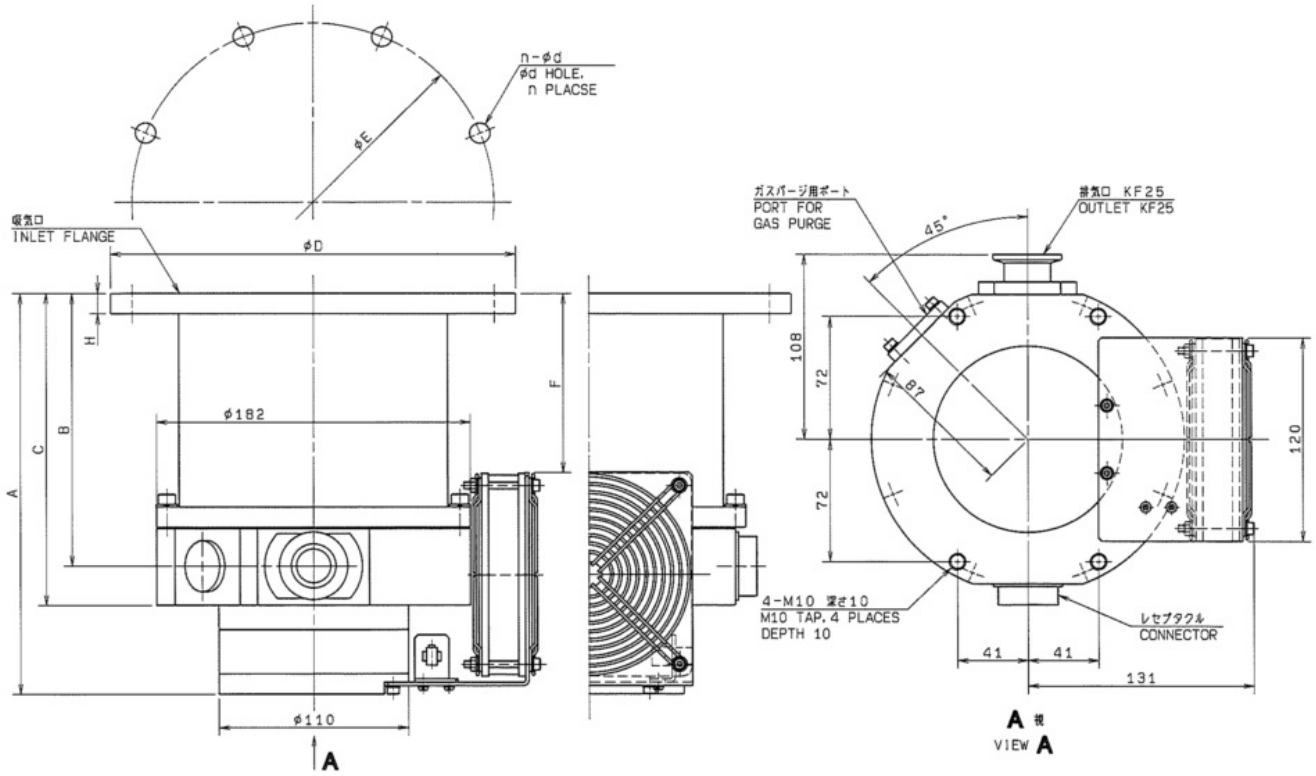

Inlet flange	A	B	C	$\phi D$	$\phi E$	$n-\phi d$	F	H
VG150	235	160	183	$\phi 235$	$\phi 210$	8- $\phi 12$	105	12
ICF203	238	163	186	$\phi 203$	$\phi 181$	20- $\phi 8.4$	108	22

Fig.1-1 UTM400A-MS (Air cooled)

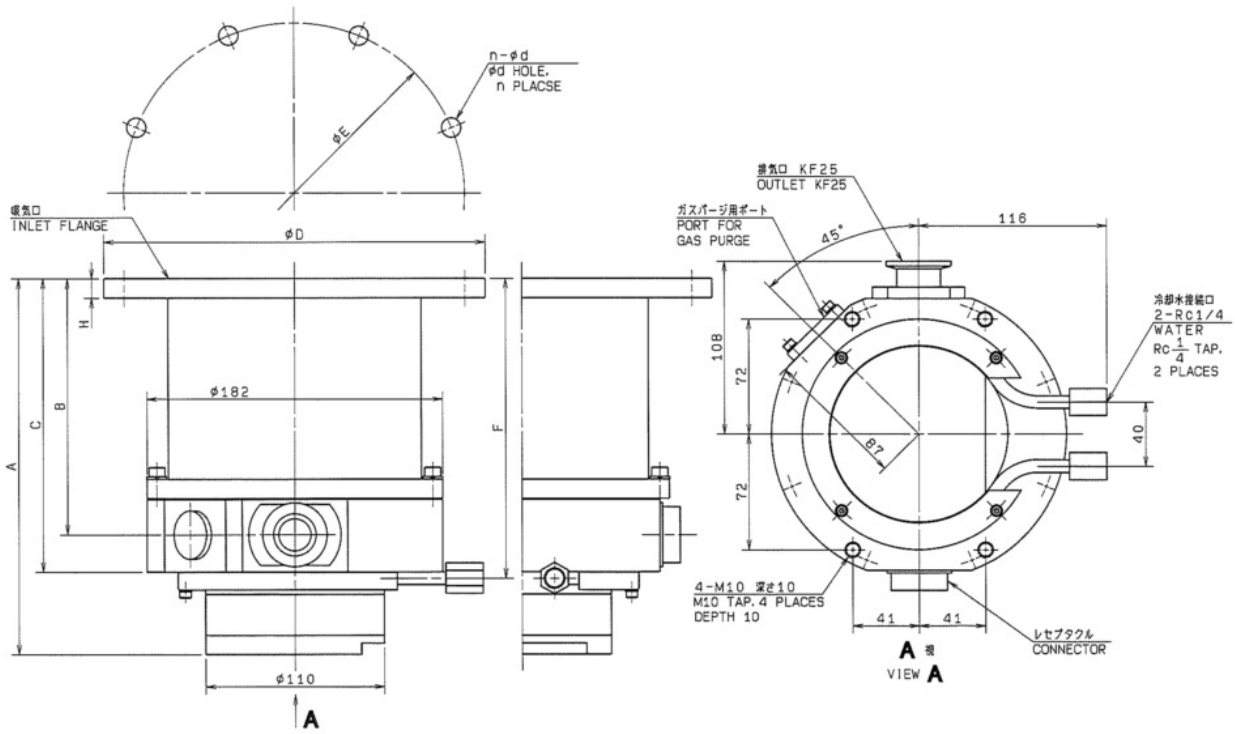

Inlet flange	A	B	C	$\phi D$	$\phi E$	n- $\phi d$	F	H
VG150	235	160	183	$\phi 235$	$\phi 210$	8- $\phi 12$	187	12
ICF203	238	163	186	$\phi 203$	$\phi 181$	20- $\phi 8.4$	190	22

**Fig.1-2 UTM400A-MS (Water cooled)**

---

**1.2.2 Standard Accessories**

---

	Description	Q'ty	Notes
1	Gasket (inlet flange) (Note)	1	VG : O-ring gasket ICF : Copper gasket
2	Dust cap (outlet flange)	1	KF40
3	Instruction manual	1	

(Note) One of followings.

No Text



# IDENTIFICATION AND FUNCTION

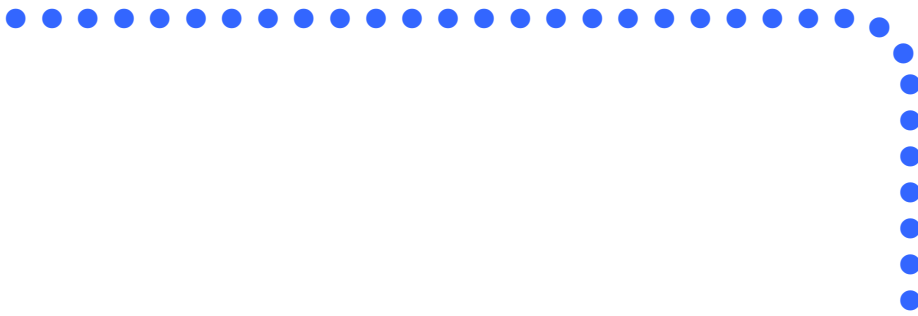

2.1 Pump Main Unit

# 2.1 Pump Main Unit

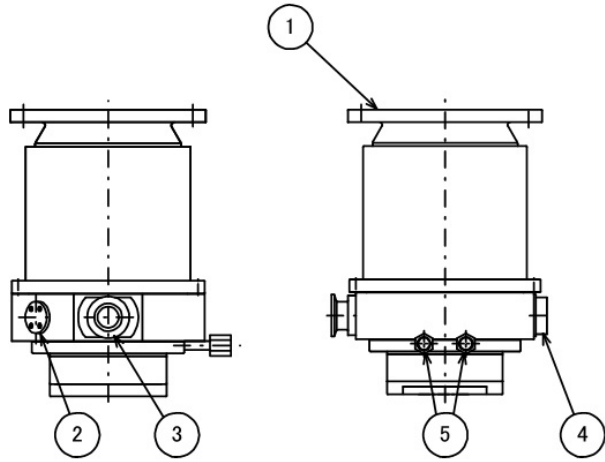

**Water cooled type**

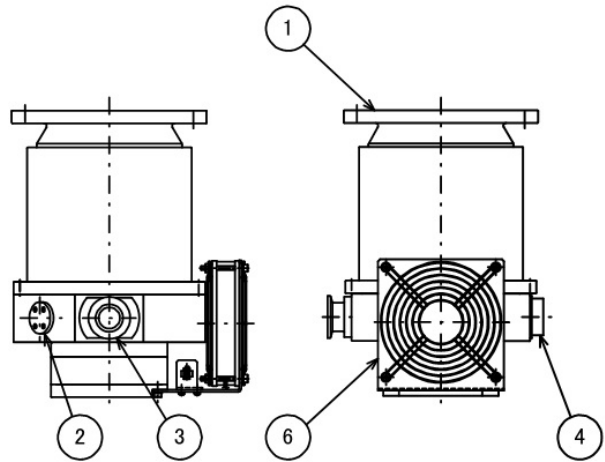

**Air cooled type**

**Fig.2-1 Pump Main Unit**

- (1) INLET FLANGE..... Inlet flange, joint the turbo molecular pump
- (2) PORT FOR GAS PURGE..... Gas purge adapter port  
(Refer to Section 7 "GAS PURGE".)
- (3) OUTLET FLANGE..... Outlet flange, connect a backing vacuum pump or its related pipe connection
- (4) CONTROL CONNECTOR..... Control cable receptacle.
- (5) COOLING WATER PIPELINE..... Cooling water pipe connector
- (6) COOLING FAN..... Cooling Fan

# CONSTRUCTION AND PRINCIPLE

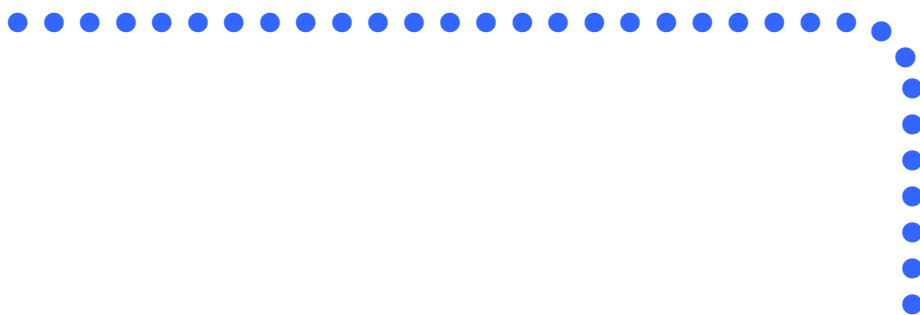

- 3.1 Pump Construction
- 3.2 Principle of Turbo Molecular Pumping

## 3.1 Pump Construction

Fig. 3-1 is a sectional drawing of UTM-MS series magnetic bearing type turbo molecular pump. The built-in high frequency motor (1) is accelerated to the specified revolutions (speed) by the high frequency controller. Rotor blades (4) are fitted onto the drive shaft (3) and the stator blades (5) are arranged in between the rotor blades. A positioning spacer (6) is inserted between the stator blades. The configurations and profiles of the stator blades and rotor blades are designed for high efficiencies in various applications. The upper stages of the rotor blade and stator blade configurations are ideally designed for high gas throughput. The compression ratio of the stator blades and rotor blades becomes higher as the gas molecules converge into the lower stage configurations. The profiles of the stator blades and rotor blades are matched for the desired function. A radial magnetic bearing (7) is used at the top and bottom of the drive shaft. The axial magnetic bearings (8) are used to levitate a disk attached to the drive shaft between the axial magnetic bearings. Each magnetic bearing is provided with a gap sensor (10) to detect the rotor position. Fig. 3-2 illustrates the outline of 5-axes control. The rotor is levitated by the control of these 5-axes allowing rotational freedom.

A touchdown bearing is used at the top and bottom of the casing for safety protection of the rotor and pump should the magnetic bearings become damaged. The touchdown bearings are dry and oil free. The cooling water pipe (14) is provided to cool the pump. With the air-cooled turbo molecular pumps, cooling fans are provided instead of the cooling water pipe (14).

## 3.2 Principle of Turbo Molecular Pumping

The principle of turbo molecular pumping assumes gas molecules collide with a surface plane (the blade of the pump rotor) moving in a radial span of very high speed in a space with an enlarged mean free gas path (generally a vacuum area of less pressure than 0.1 Pa). Assuming no heat is exchanged between the gas molecule and the pump rotor blade, the speed of the pump rotor blade is added to the speed of the gas molecule, converting the gas molecule's non-oriented thermal motion to a motion with direction. Thus the gas molecule has received an impulse in a desired flow direction.

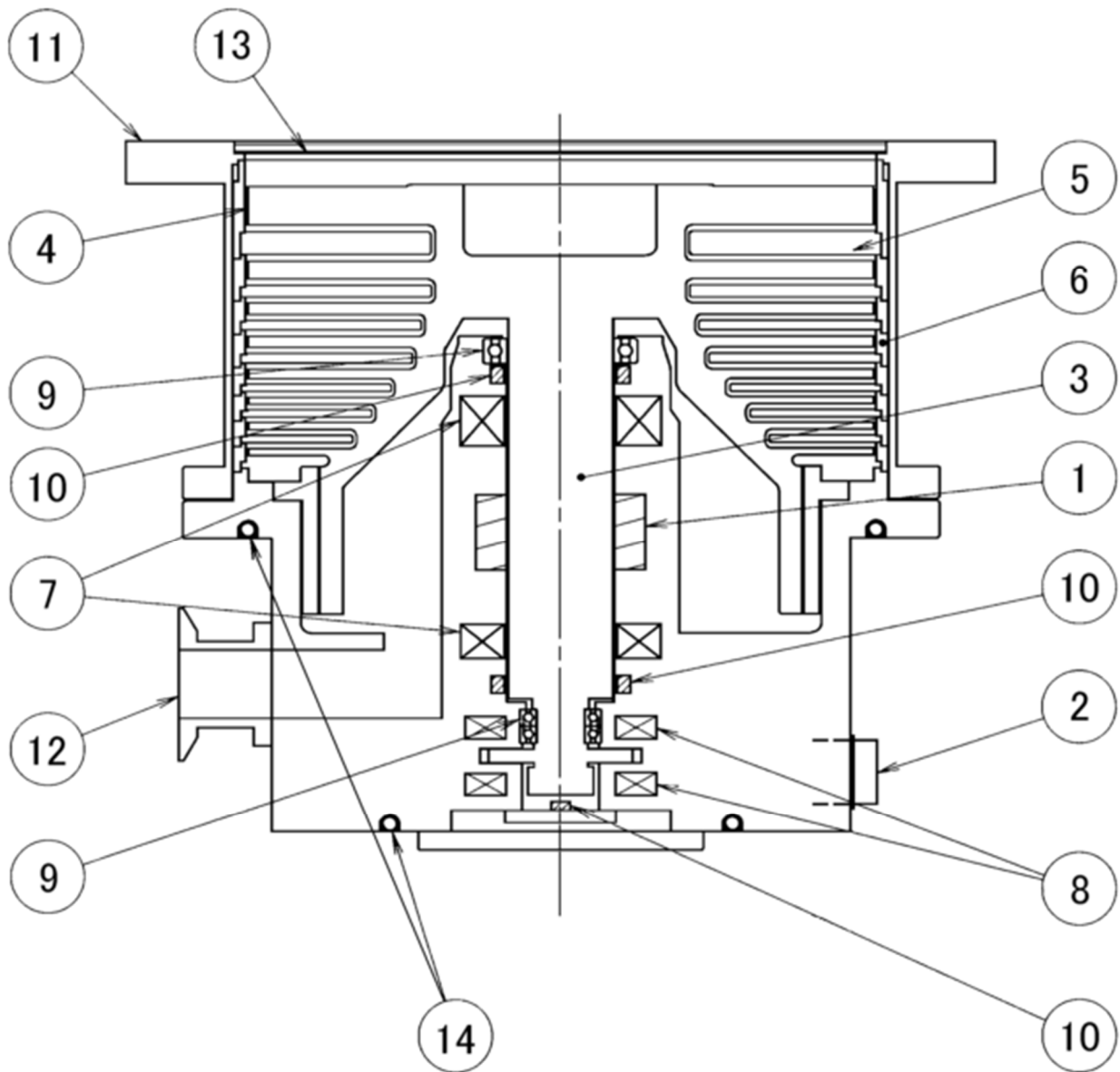

**Fig. 3-1 Pump Sectional Drawing**

- |                          |                             |                             |
|--------------------------|-----------------------------|-----------------------------|
| (1) High frequency motor | (6) Spacer                  | (11) Inlet flange           |
| (2) Receptacle           | (7) Radial magnetic bearing | (12) Outlet flange          |
| (3) Drive shaft          | (8) Axial magnetic bearing  | (13) Protective net         |
| (4) Rotor blade          | (9) Touch-down bearing      | (14) Cooling water pipeline |
| (5) Stator blade         | (10) Gap sensor             | (pipe connection port)      |

The movement of an object has 6 degrees of freedom. Levitation can be achieved in a turbo molecular pump by controlling the following 5 degrees of freedom (excluding the rotational degree (Z axis) of freedom).

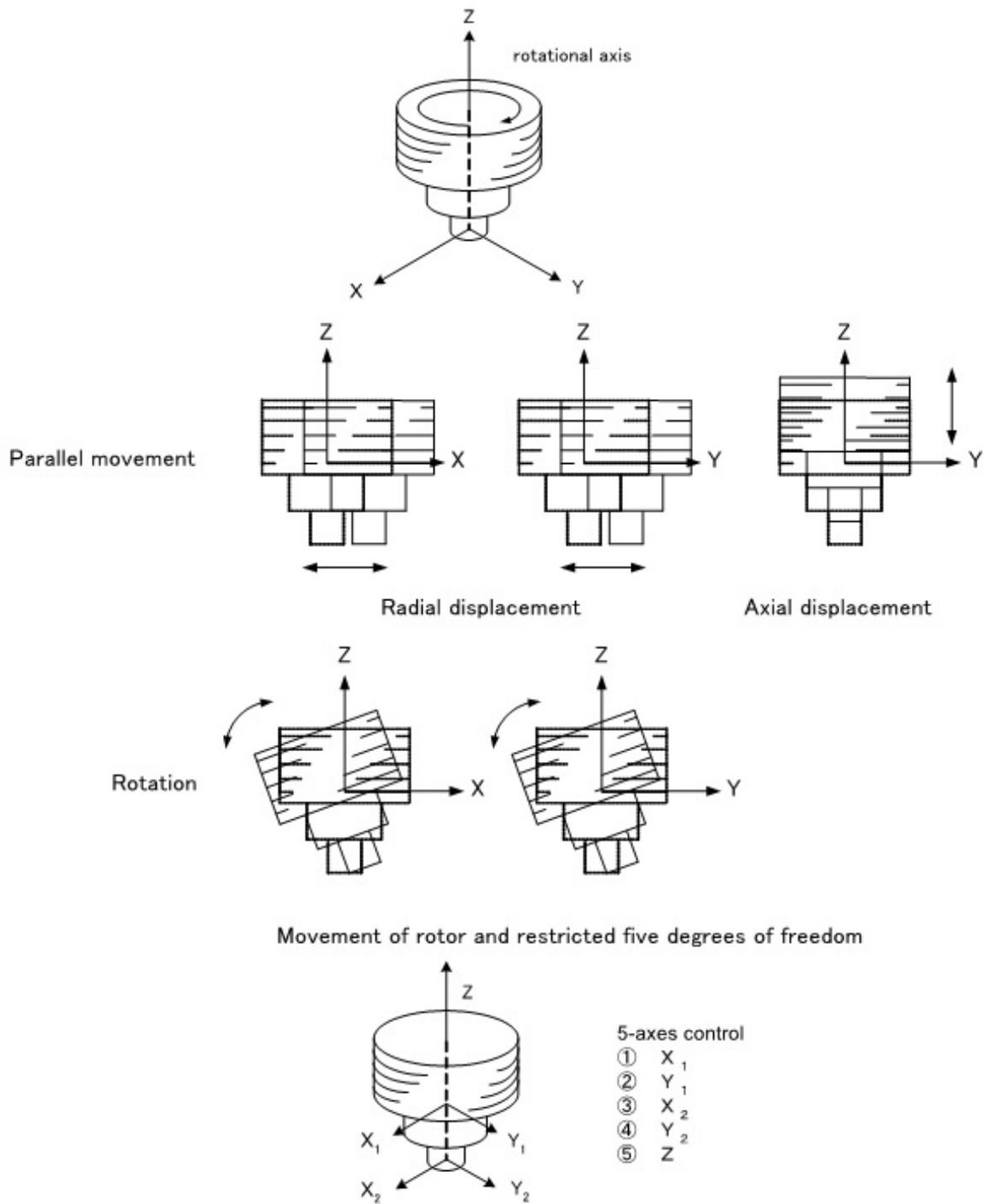

**Fig. 3-2 Outline of 5-Axes Control**

# SPECIFICATIONS



## 4.1 Standard Specifications for Pump Unit

# 4.1 Standard Specifications for Pump Unit

**Water cooled type**

Model		UTM300A-MS	UTM400A-MS
Inlet flange		VG100 / ICF152	VG150 / ICF203
Outlet flange		KF25	
Ultimate pressure (after baking) (Note 1)		10 <sup>-7</sup> Pa order	
Maximum allowable inlet pressure		200Pa	
Maximum allowable outlet pressure		400Pa	
Pumping speed (Note 2)	N <sub>2</sub>	320 L/s	420 L/s
	He	340 L/s	360 L/s
	H <sub>2</sub>	320 L/s	340 L/s
Compression ratio	N <sub>2</sub>	1×10 <sup>9</sup>	
	He	8×10 <sup>4</sup>	
	H <sub>2</sub>	1×10 <sup>4</sup>	
Rated speed		45,000rpm	
Start-up time		5 minutes or less	
Mounting position		In any desired direction (Refer to Section 5)	
Bake-out temperature at an inlet flange		120 degrees C. or less	
Vibration level (by ULVAC KIKO's method)		0.012 μm or less (0-peak)	
Noise		60 dB(A) or less	
Recommended flow rate of purge gas		20 to 30 mL/min (Note 3)	
Recommended pumping speed of backing pump in case of gas purge		200 L/min or more	
Admissible ambient magnetic field	Radial direction	3 mT	
	Axial direction	15 mT	
Water	Flow rate	1 to 3 L/min	
	Pressure	0.2 to 0.5 MPa	
	Temperature	5 to 30 degrees C.	
Mass		14 kg	

(Note 1) When using a metal gasket at the inlet flange. When using an o-ring gasket, the ultimate pressure is 10<sup>-7</sup> Pa order.

(Note 2) Without a protective net. Pumping speed for N<sub>2</sub> gas when protective net is used is UTM300A-MS: 300 L/s, UTM400A-MS: 400 L/s.

(Note 3) mL/min: volume flow rate at 0 degrees C., 1 atm (Compatible with SCCM).



**Air cooled type**

Model		UTM300A-MS	UTM400A-MS
Inlet flange		VG100 / ICF152	VG150 / ICF203
Outlet flange		KF25	
Cooling method		Air cooled	
Ultimate pressure (after baking) (Note 1)		10 <sup>-7</sup> Pa order	
Maximum allowable inlet pressure		200Pa	
Maximum allowable outlet pressure		400Pa	
Pumping speed (Note 2)	N <sub>2</sub>	320 L/s	420 L/s
	He	340 L/s	360 L/s
	H <sub>2</sub>	320 L/s	340 L/s
Compression ratio	N <sub>2</sub>	1×10 <sup>9</sup>	
	He	8×10 <sup>4</sup>	
	H <sub>2</sub>	1×10 <sup>4</sup>	
Rated speed		45,000rpm	
Start-up time		5 minutes or less	
Mounting position		In any desired direction (Refer to Section 5)	
Bake-out temperature at an inlet flange		120 degrees C. or less	
Vibration level (by ULVAC KIKO's method)		0.012 μm or less (0-peak)	
Noise		60 dB(A) or less	
Recommended flow rate of purge gas		20 to 30 mL/min (Note 3)	
Recommended pumping speed of backing pump in case of gas purge		200 L/min or more	
Admissible ambient magnetic field	Radial direction	3 mT	
	Axial direction	15 mT	
Mass		14 kg	

(Note 1) When using a metal gasket at the inlet flange. When using an o-ring gasket, the ultimate pressure is 10<sup>-7</sup> Pa order.

(Note 2) Without a protective net. Pumping speed for N<sub>2</sub> gas when protective net is used is UTM300A-MS: 300 L/s, UTM400A-MS: 400 L/s.

(Note 3) mL/min: volume flow rate at 0 degrees C., 1 atm (Compatible with SCCM).

No Text

# INSTALLATION



- 5.1 Installation
  - 5.1.1 Pump Mounting Direction
  - 5.1.2 Installation of the Pump
  - 5.1.3 Example of Piping Connection
  - 5.1.4 Center of Gravity of the Pump
- 5.2 Connection of the Pump to the Controller
- 5.3 Interlock for Vacuum System
- 5.4 Notes on Transportation

# 5.1 Installation

## 5.1.1 Pump Mounting Direction

This turbo molecular pump can be installed in vertical, horizontal, inverted, or oblique position. The outlet port of the turbo molecular pump should face horizontally or vertically when installing the pump horizontally and obliquely.

When an installation direction is non-appropriate, reliability of operation may deteriorate (Refer to Fig. 5-1).

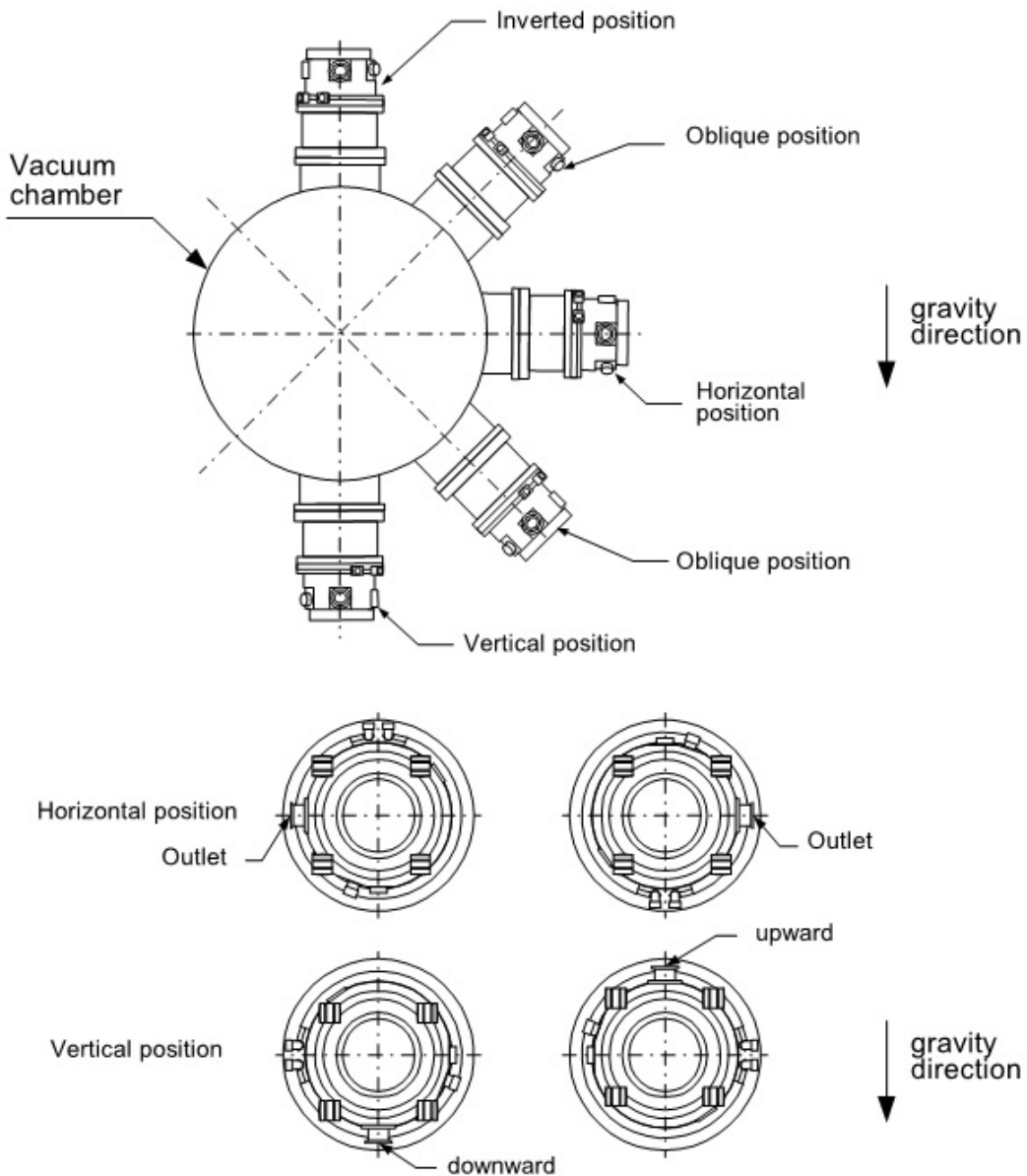

**Fig. 5-1 Mounting Direction of the Turbo Molecular Pump**

**5.1.2 Installation of the Pump**

---

**WARNING**

Do not operate the turbo molecular pump until safety is confirmed.

- The rotor assembly of the turbo molecular pump rotates at high speed. Large rapid shutdown torque should be generated when abnormality occurs in the pump by any chance. Incidental accident will cause the pump to drop out and to make a catastrophe if the pump is fixed by insufficient method.
  - The method to fix the pump is different depending on the pump model and the size of inlet flange of the pump.
  - Host equipment should be fixed to the floor so as not to move. Host equipment should be designed to have enough margins in strength, in preparation for an emergency accident.
- 
- 

**WARNING**

Ensure that no oil mist or hazardous substances are present in process line as safe ducting procedure when turbo molecular pump is installed to host equipment.

---

---

**CAUTION**

Avoid to install the pump at the following places.

- (1) Place where the pump is inevitably exposed to significant vibration and impact.
- (2) Unstable place.
- (3) Place where the pump is inevitably exposed to magnetic field and radioactive ray.

The pump proper is a precision machine. Be careful not to apply abnormal vibration, shock/ impact to it during transportation. This pump is not connected to ground. Please provide PE (Protective earth) connection to the chassis of pump in final application. This pump is not an explosion-proof product. This pump is not intended to be used in a potentially explosive atmosphere.

---

## CAUTION

The pump surface may get hot, there are risk of burn.

Prevent the installation, operation, maintenance, and service personnel from contacting the pump surface in all tasks that they are intended to perform.

## NOTICE

Before touching the pump internals and the vacuum chamber, put a pair of nylon gloves without fail. Avoid direct touch with them. Internal contamination of the vacuum chamber or the pump would cause deterioration of adequate vacuuming performance.

When using a hydraulic rotary pump with vibration of wide amplitude, as a backing vacuum pump, undertake proper anti-vibration measure (As a guideline, control the vibration to 0.1 G/ 50 Hz max at the outlet connection port of the turbo molecular pump).

This pump is a precision pump. To protect the pump from torsion due to external piping load, use a bellows joint or a flexible tube to either the pump inlet or outlet, without fail.

## CAUTION

The center of gravity of the pump is indicated in Fig. 5-6. Be sure that the pump does not move or fall down during installation or storage.

Fix the pump in the manner shown in Fig. 5-2

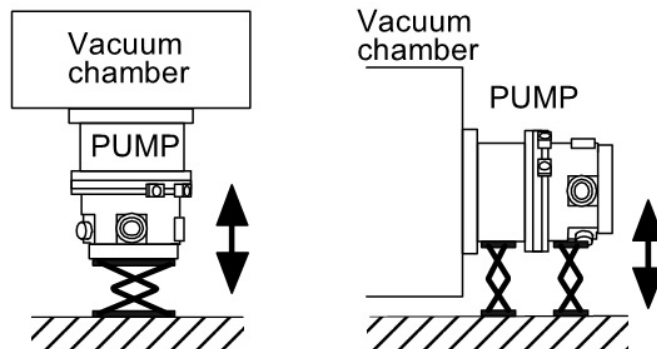

**Fig. 5-2 Lifting Method**

It is recommended to fix the inlet flange of the turbo molecular pump to the flange of vacuum chamber, and the base bottom of the pump to the frame of host equipment (Refer to Fig. 5-3).

When you fix the pump, use the bolts regulated grade, size, number and tightening torque (Refer to Table 5-1 and Table 5-2). And use all the bolt-holes of the inlet flange of the pump. Refer to Fig. 5-4 about usage of the bolt.

The sets of half-thread bolt and nut should be used to fix the inlet flange of the pump. Make installation with the cylindrical part of the bolt (not thread part) fit in the mating section of flanges.

When you connect piping or valve between the chamber and the pump, please fix the same method as the inlet flange

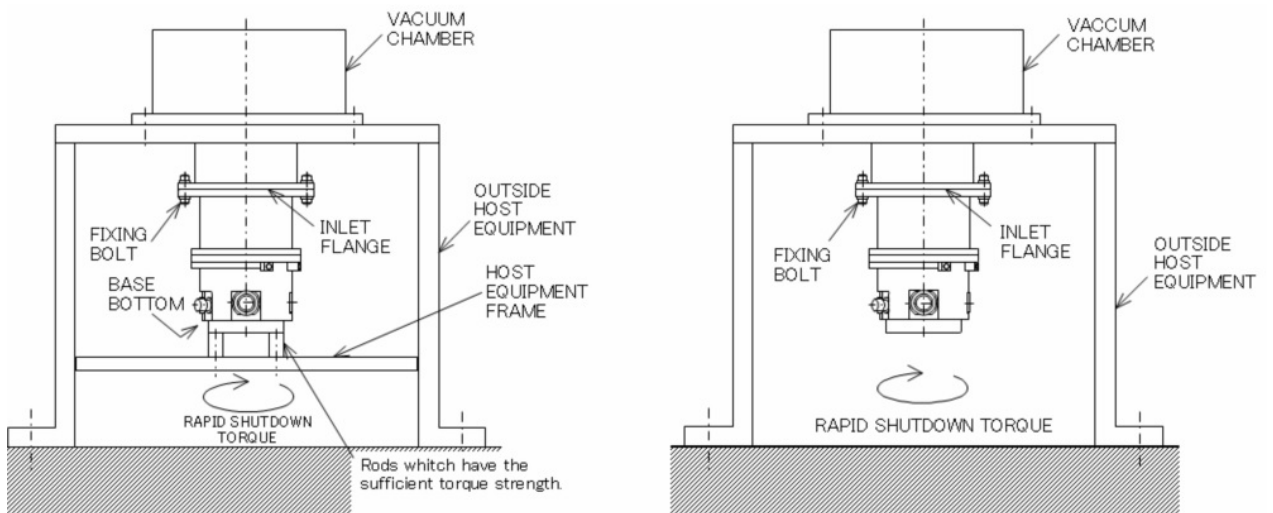

**[recommend]**

**Fixed both by the inlet flange and the base of TMP**

**Fixed only by the inlet flange of TMP**

Description	Rapid shutdown torque [N•m] (Note)
UTM300A-MS / UTM400A-MS	6,700

(Note)Rapid shutdown torque is the typical value measured by the ULVAC KIKO's test condition. The torque to transmit to host equipment might be different according to the rigidity of host equipment. Host equipment should be designed to have enough margins in strength.

**Fig. 5-3 Installation of UTM-MS series**

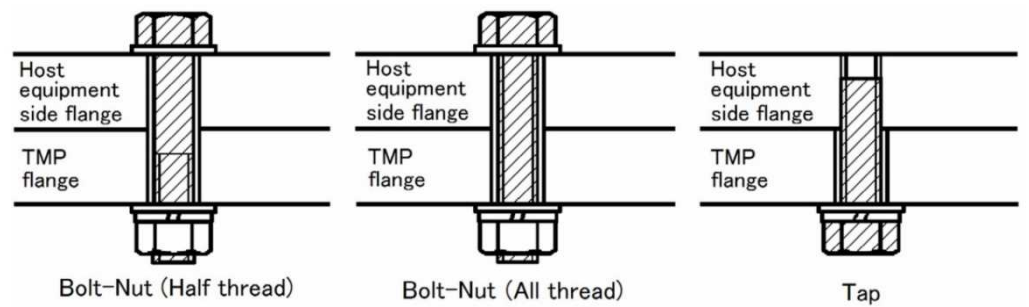

**Fig. 5-4 How to Use of the Bolt**

**Table 5-1 The Recommended Fixing Bolt**

■ Both by the inlet flange and the base (recommended method)  
**Bolt-Nut (Half thread · All thread) · Tap**

Fixing method		Both by the inlet flange and the base (recommended method)			
Inlet flange		VG100	ICF152 (Note)	VG150	ICF203
Bolt size , Quantity	Inlet flange	M10, 8PC	M8, 16PC	M10, 8PC	M8, 20PC
	Base	M10, 4PC			
Material		Stainless steel			
Grade		A2-70 (JIS B 1054 / ISO-3506)			
Washer		Plain washer and spring lock washer			

(Note 1) In the case of ICF152, only the stud bolts can be use, because of narrow space.

■ Only by the inlet flange

**Bolt-Nut (Half thread · All thread) · Tap**

Fixing method		Only by the inlet flange			
Inlet flange		VG100	ICF152 (Note)	VG150	ICF203
Bolt size , Quantity		M10, 8PC	M8, 16PC	M10, 8PC	M8, 20PC
Material		Stainless steel			
Grade		A2-70 (JIS B 1054 / ISO-3506)			
Washer		Plain washer and spring lock washer			

(Note 1) In the case of ICF152, only the stud bolts can be use, because of narrow space.

**Table 5-2 Tightening Torque of the Fixing Bolt**

Size of bolt	Tightening torque [N·m]
M8	4.7 to 7.6
M10	9.4 to 15



**5.1.3 Example of Piping Connection**

Connect a backing vacuum pump or its related pipe connection flange to the outlet flange of the pump (Refer to Fig. 5-5)

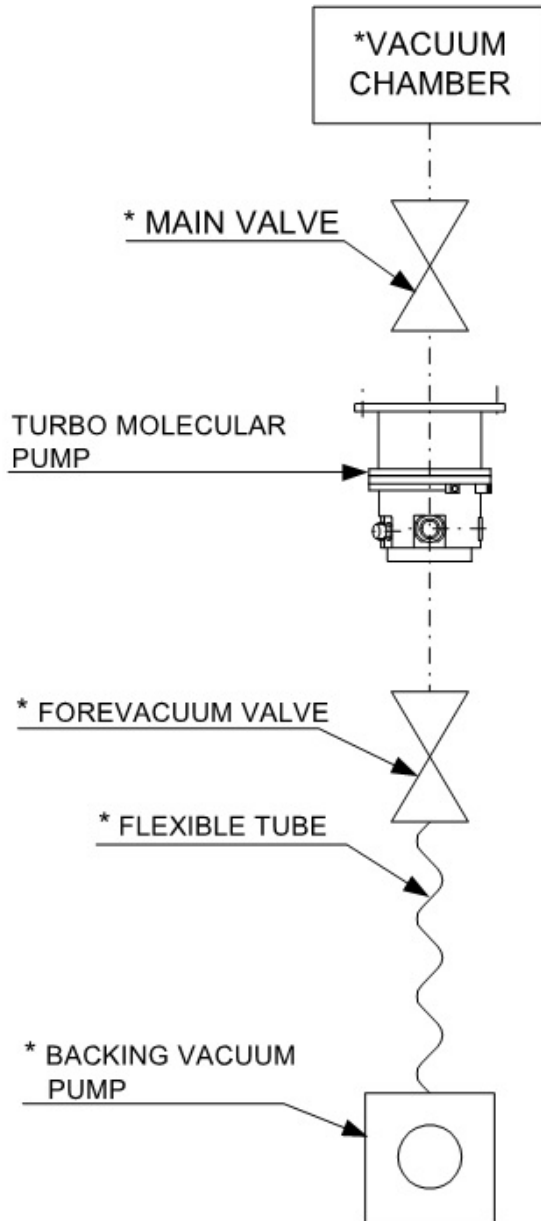

\* marks are not attached to this turbo molecular pump set.

**Fig. 5-5 Example of Exhaust Line**

When gas purge required, connect the gas purge pipeline to the gas purge port (For the gas purge detail, refer to Section 7 "GAS PURGE").

After complete piping connection, check for perfect airtightness by helium leak test.

### Connection of Cooling Water Line:

Connect cooling water pipes to these pumps. When connecting the cooling water pipes, screw the pipe joint while also holding the nozzle of the pump with a spanner in order to avoid deforming the cooling water pipe, as illustrated in Fig. 5-6.

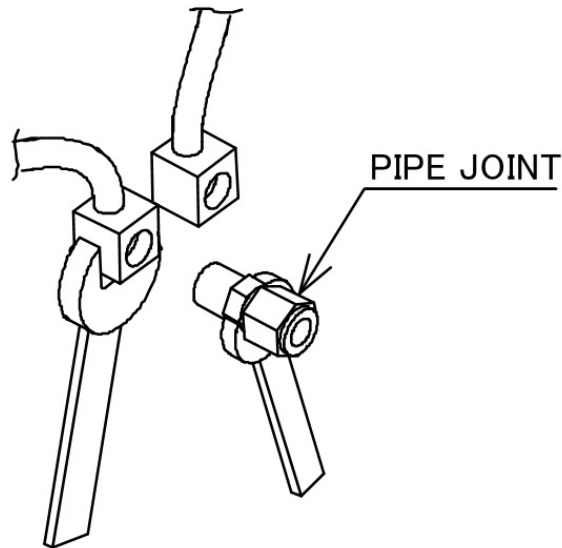

**Fig. 5-6 Cooling Water Piping Connection**

### 5.1.4 Center of Gravity of the Pump

The center of gravity of the pump is shown in Fig. 5-7. Fix securely to avoid moving or falling down in the event of an earthquake.

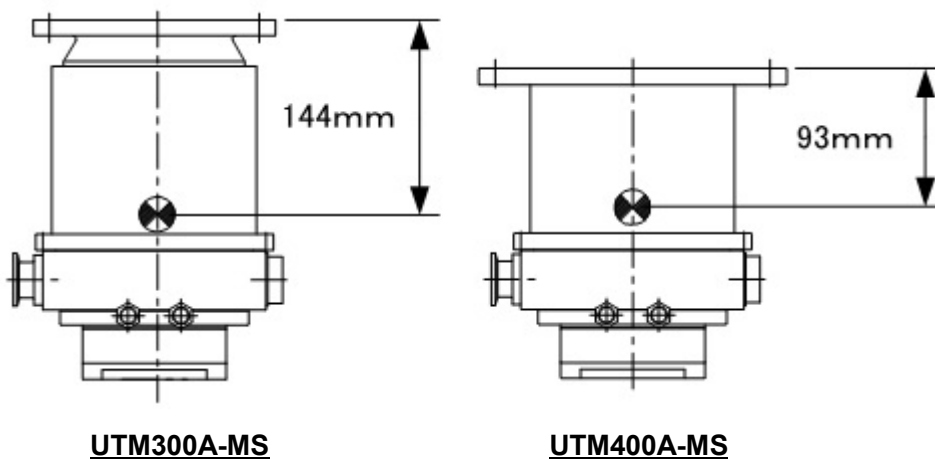

**Fig. 5-7 Center of Gravity of the Pump**

## 5.2 Connection of the Pump to the Controller

---

**CAUTION**

Insert straight the control cable connector after checking its key direction.

Inserting it in oblique direction would cause damage of the connector pins. After the insertion, turn the cable connector clockwise until the rotation lock clicks.

---

---

**CAUTION**

Don't disconnect each cable while the pump is running. Particularly before disconnecting the control cable, check complete shutdown of the pump by ROTATION lamp goes out and, thereafter, turn off the POWER switch.

---

For information regarding cable connections please refer to the controller Instruction Manual.

## 5.3 Interlock for Vacuum System

- (1) When using, as a backing vacuum pump, a vacuum pump with no check mechanism (backstream flow prevention) such as dry vacuum pump, etc., install a forevacuum valve between the turbo molecular pump and the backing vacuum pump to prevent rapid inverse flow of exhausted gas. And close the forevacuum valve before the backing vacuum pump stops (Refer to Fig. 5-5).
- (2) Even when "ALARM" signal is emitted, don't cut off the controller while "ROTATION" signal is being emitted. Even when ALARM lamp lights, don't cut off the controller while ROTATION lamp lighting.
- (3) If "ALARM" signal is emitted or ALARM lamp lights, shut down the backing vacuum pump or close the forevacuum valve immediately. Furthermore, when main valve is installed between the turbo molecular pump and the vacuum chamber, close this valve, too.
- (4) Provide a flowmeter on the downstream of cooling water line, otherwise the turbo molecular pump will shut down and otherwise set up the interlock which the pump cannot start against cut off of water supply.

For more information regarding signals, please refer to the controller Instruction Manual.

## 5.4 Notes on Transportation

This product is precision equipment. Do not give any strong impact or continuous vibration in transportation, otherwise the product could be damaged. In transportation, please use a means of transportation which have vibration-proof function (an air suspension truck, for example).

Especially when passing by rough road, we recommend that the product is transported keeping the packing condition when it ships from ULVAC KIKO.

When the product is put on the high temperature / humidity environment for a long time, it causes the breakdown of the product due to corrosion of mechanical parts or performance loss of electrical parts.

Please transport or store the product under an appropriate environment.

# OPERATION

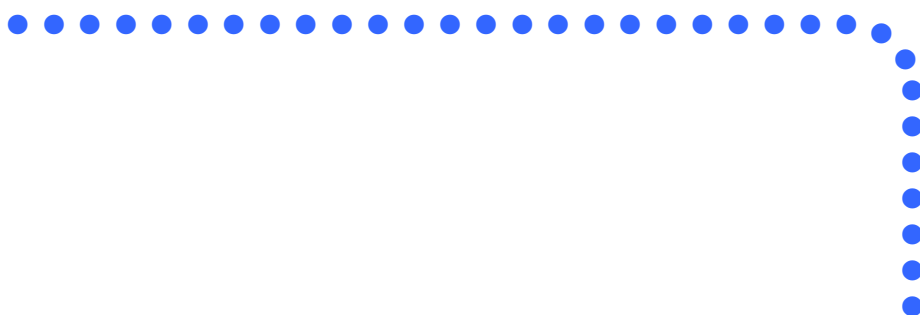

- 6.1 Outline
  - 6.1.1 Introduction
- 6.2 Start-up Preparation
  - 6.2.1 Start-up Preparation
- 6.3 Start-up
  - 6.3.1 Start-up Sequence
- 6.4 Shutting Down
- 6.5 Baking Operation

# 6.1 Outline

---

**CAUTION**

Neither disconnect and reconnect each cable while the pump is running.

Particularly for unplugging the control cable from the receptacle, check complete shutdown of the pump by ROTATION lamp goes out and, thereafter, turn off the POWER switch.

---

---

**CAUTION**

Do not turn the power off while the pump is running. The touch-down bearing may need to be replaced if the power is turned off repeatedly during operation.

If the power is turned off during rotation, power from regenerative braking will keep the rotor levitated. After slowing down, levitation stops and the rotor is supported by the touchdown bearing. Therefore, repeated touchdowns will reduce the life of the bearing.

---

---

## 6.1.1 Introduction

---

Please operate by the Controller. For more information regarding an operation, please refer to the controller Instruction Manual.

## 6.2 Start-up Preparation

Please select "LOCAL" or "REMOTE" at the switch of the controller.

For more information regarding operation, please refer to the controller Instruction Manual.

---

### 6.2.1 Start-up Preparation

---

- (1) Feed the cooling water into the cooling line (for cooling water method).
- (2) Turn on the POWER switch of the controller and check if the POWER lamp lights.  
And the rotor of the turbo molecular pump is levitated by the magnetic bearing.
- (3) Evacuate the turbo molecular pump by using a backing vacuum pump.
- (4) Start-up preparation is complete if the pressure in the turbo molecular pump reduces below 200 Pa.

## 6.3 Start-up

---

### 6.3.1 Start-up Sequence

---

- (1) Start-up begins when the Section 6.2.1 "Start-up Preparation" is complete.
- (2) For more information regarding an operation, please refer to the controller Instruction Manual.

#### REFERENCE

A pressure check using the vacuum gauge attached to the pump inlet shows that the pressure reduces gradually after rotation starts.。

## 6.4 Shutting Down

### CAUTION

After having operated the turbo molecular pump for evacuation of corrosive gas, keep the pump internal as vacuumed even after shutdown. Inflow of water content in the air to the pump internal would cause rapid corrosion trouble of the pump internals. The pump corrosion may result in damaging the vacuum vessel interior and other units, causing pressure fluctuation by stopping the pump and dispersal of parts.

### CAUTION

When increasing internal pressure of the turbo molecular pump up to around the atmospheric pressure by use of inert gas, etc., adjust the pressure reducing valve so that the internal pressure of the same pump does not exceed 20 kPa [GAUGE]

For shut-down of the turbo molecular pump, follow the sequence below.

#### **Preparations Prior to Shutting Down Operation:**

- (1) Check that process gas inflow is in complete stop. When main valve is provided between the turbo molecular pump and vacuum chamber, close the valve, too.
- (2) When purge gas is being fed into the turbo molecular pump, stop the gas feed, too.
- (3) When forevacuum valve is provided between the turbo molecular pump and backing vacuum pump, close the valve, too.

#### **Shutting Down Sequence in LOCAL Mode:**

- (1) For more information regarding an operation, please refer to the controller Instruction Manual.
- (2) Stop the cooling water flow (for cooling water method).

When the turbo molecular pump is turned off after pumping a corrosive gas, maintain a vacuum inside the turbo molecular pump or purge the interior of the pump with an inert gas.

Further, in such a case when a hydraulic rotary vacuum pump is used as backing vacuum pump and there is possible reverse flow and diffusion of oil from the backing vacuum pump, return the pump internal pressure to atmospheric pressure using dry nitrogen gas, after complete shut-down of the pump [ROTATION lamp goes out], to prevent the turbo molecular pump from being contaminated with oil vapor.

For shutting down the turbo molecular pump in running at high speed with infeed of dry nitrogen gas to the pump, keep the nitrogen gas flow rate at 1500 mL/min maximum.



**REFERENCE**

ROTATION lamp goes out or "ROTATION" signal turns off when the pump rotational speed is 60 rpm or less. Turning off the POWER switch permits the pump rotor to be supported by the touch-down bearings.

# 6.5 Baking Operation

**CAUTION**

During baking operation, cool down the turbo molecular pump in either cooling water or cooling fan.

**CAUTION**

Baking temperature is not allowed to exceed 120 degrees C.

The baking heater is installed near the inlet flange.

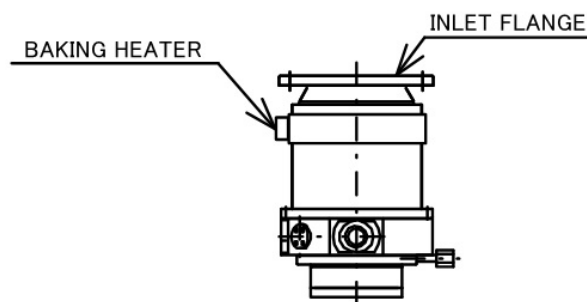

**Fig. 6-1 Installation of Baking Heater**

Perform baking treatment when the inlet pressure of the turbo molecular pump is  $1 \times 10^{-3}$  Pa or less. It is necessary to apply baking to not only the vacuum chamber but also the pump proper in order to keep an exhausting vessel at super high vacuum. However, the baking temperature is not allowed to exceed 120 degrees C. because generally the rotor of the turbo molecular pump is made of aluminum alloy.

For baking application to the pump proper, carefully adjust the baking temperature. For the purpose, special heater is supplied with the pump system considering the temperature requirements. Use this heater for control of the baking temperature.

No Text



# GAS PURGE



This turbo molecular pump incorporates a gas purge port (Fig. 2-1 (2)). This turbo molecular pump need to flow the purge gas for protection of the bearings, when it evacuates a lot of corrosive gas. The proper purge gas flow rate is between 20 and 30 mL/min.

Joint	Orifice size
KF10 (Dust cap)	φ0.5mm

Fig. 7-1 shows an example of a gas purge piping diagram. Use a filter element size of 5 μm, or less. Use flow control valve to control the flow rate.

Gas feed start	After starting backing vacuum pump; before evacuating process gas
Gas feed stop	After exhausting process gas sufficiently; before stopping backing vacuum pump
Type of gas	Nitrogen (Purity > 99.99 %)

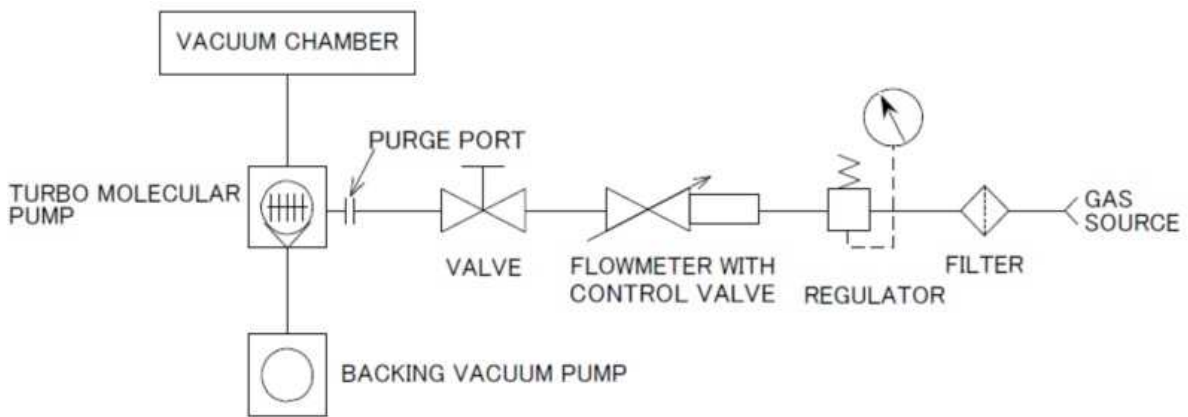

**Fig. 7-1 Gas Purge Method (adaptor with Φ0.5 mm orifice)**

# TURBO MOLECULAR PUMP RECONDITION

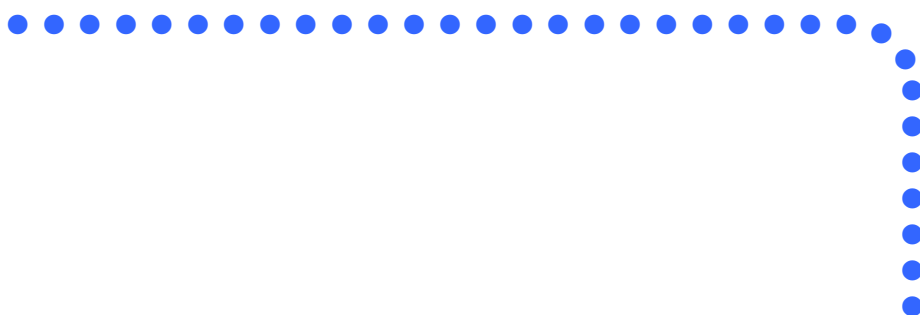

- 8.1 Recommended Maintenance Intervals
- 8.2 Turbo Molecular Pump Decontamination
- 8.3 Touch-down Bearing Replacement
- 8.4 Check of the Rotor Blades
- 8.5 Turbo Molecular Pump Return Request

# 8.1 Recommended Maintenance Intervals

It is different for deterioration progress speed of each part changes greatly by pump condition (Magnetic-bearings, sensors and motor need to change new ones per 3-5 years in addition in using corrosive gas, rotor temperature rises up depending on process, therefore it's possible the rotor life is short). Refer to the following list as overhaul of each process.

These are not terms of warranty.

	Process	Recommended maintenance intervals
1	Non-active gas (Sputtering, Evaporation and so on) and Light load process	3 years
2	CVD, Ion implanter and process of having deposition pump inside	1 - 2 years
3	Etching process	6 months - 1 year

(1) Recommended maintenance intervals for parts

1) Non-active gas and Light load process

	Part name	Recommended maintenance intervals
1	Touch down bearing	3 years
2	Shaft	7 years
3	Rotor	It has a possibility of under 2 years (Dependent on condition)
4	Motor	7 years
5	Magnetic bearing parts	
6	Cooling fan (Note 1)	5 years
7	Heater (Note 1)	
8	Pipe for water cooling (In case of copper material only) (Note 1)	3 - 5 years

2) Use of corrosive gas

	Part name	Recommended maintenance intervals
1	Touch down bearing	1 years
2	Shaft	5 years
3	Rotor	It has a possibility of under 1 years (Dependent on condition)
4	Motor	5 years
5	Magnetic bearing parts	
6	Cooling fan (Note 1)	5 years
7	Heater (Note 1)	
8	Pipe for water cooling (In case of copper material only) (Note 1)	3 - 5 years
9	Orifice (Note 1)	1 years

(Note 1) Only as for the adaptation model.

(2) Recommended maintenance intervals for other parts

1) It has the possibility that the following part is exchanged, when cleaning TMP.

Part name
55-pin Receptacle

2) Others

When exchanging parts, it has possibility that other parts are exchanged for improving a reliability (Example: Old type lower and upper radial sensor had changed dimensions for reliability. When exchanging them, these housing must also be exchanged).

## 8.2 Turbo Molecular Pump Decontamination

All expenses incurred with the decontamination of the turbo molecular pump are the responsibility of the customer.

## 8.3 Touch-down Bearing Replacement

The touch-down bearing (Fig. 3-1 (9)) is the only component of ULVAC KIKO's turbo molecular pump that is subjected to friction and wear, normally occurring only during electrical power failure. Repeated and/or frequent rotor touch down will cause wear and bigger rotational resistance and require replacement of touch down bearings.

The replacement of the touch-down bearing is done only by ULVAC KIKO or an approved service company.

## 8.4 Check of the Rotor Blades

Rotor blades of turbo molecular pump are high-speed rotor made of aluminum alloy. It has the possibility that material strength deteriorates, specially when corrosive gas is evacuated. Regular check (Customer is liable for the cost) by ULVAC KIKO or a ULVAC KIKO approved/authorized service center is suggested (Every one year is recommended). ULVAC KIKO and/or the service center investigate rotor blades in every overhaul task and check and suggest a rotor replacement to customers if any cracks are found out.

## 8.5 Turbo Molecular Pump Return Request

---

**WARNING**

Improper turbo molecular pump use may be hazardous to operator's health in applications not recommended or approved by ULVAC KIKO. In the event removal of the turbo molecular pump from an application is required, full protective measures including purging of the turbo molecular pump with an inert gas and/or apparel are recommended when the turbo molecular pump has been used in applications that required the use of corrosive, reactive, stimulative, or toxic gasses.

---

---

**WARNING**

When pump is removed from host equipment, follow the procedure described below. If not, cause injury by electrical shock, water leak, or gas leak.

- (1) Power off the primary power (AC SWITCH "OFF", disconnect the power cable).
  - (2) Confirm that the lamps on the control panel turns off.
  - (3) Confirm that there is no rotational sound of touch-down bearing.
  - (4) Confirm that water line and gas line are cut off.
- 

Annual overhaul is recommended.

Overhaul, re-manufacturing, refurbishing, or repair of the turbo molecular pump system should always be performed by ULVAC KIKO or an approved service company.

The following precautions are required before forwarding the turbo molecular pump to ULVAC KIKO or an approved service company for all service related requests.

- (1) The turbo molecular pump must be void of all process gasses. Turbo molecular pumps that were operated in applications using special gasses (doping gas, epitaxial gas, film forming gas, etching gas, etc.), likely have the process by-products, reaction-produced matter, etc. Remove them from the turbo molecular pump by repeated gas purge to the pump and fill the pump with an inert gas. The pump interior must be adequately purged with inert gas before uninstalling from the unit.
- (2) The customer is required to submit MSDS (Material Safety Data Sheet) sheets and information of all gasses, materials, etc. that have been associated with the turbo molecular pump.

ULVAC KIKO will accept and perform service only on turbo molecular pumps that have been properly prepared as stated in (1) and (2) above. ULVAC KIKO will advise the customer of any failure precaution/prevention procedures that are appropriate to each individual turbo molecular pump service request.

---



**CAUTION**

When pump is removed from a equipment, drain the water from water pipe. If remained water leak from water pipe, pump body will be corroded.

After the water drained, shut water pipe by the cap which is attached at shipment.

Remove the pump in the manner shown in Fig. 8-1.

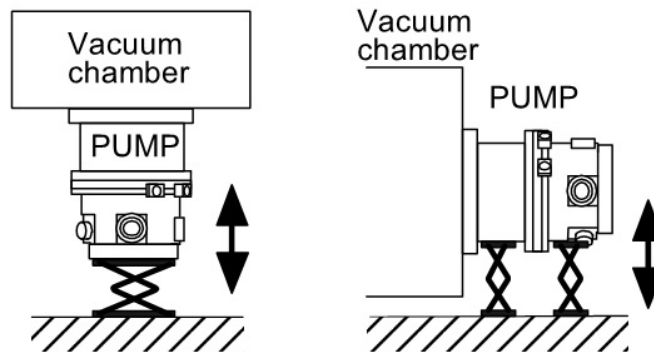

**Fig. 8-1 Way to Remove the Pump**

**CAUTION**

When the pump is returned, please pack it surely so as not to damage it by the impact, the vibration, and the high temperature and humidity environment, etc. from the outside.

Please use the packing materials which were used at shipment from ULVAC KIKO, or use the packing materials having a same quality or better.

No Text

# TROUBLESHOOTING



- 9.1 Vacuum Pressure Rise
- 9.2 Abnormal Noise and/or Vibration

## 9.1 Vacuum Pressure Rise

A rapid rise of vacuum pressure in the turbo molecular pump causes the internal motor of the turbo molecular pump to start braking and the ALARM lamp lights.

## 9.2 Abnormal Noise and/or Vibration

Should the turbo molecular pump ever generate abnormal noise and/or vibration, the turbo molecular pump operation is to be stopped immediately.

But there is possible that a race of touch-down bearing (Fig. 3-1 (9)) may make sounds for seconds when the pump internal pressure gets back to atmospheric pressure using air (or non-activity gas). This phenomena is not abnormal and make no damage to the pump, because the air whirlpool sometimes occurs and then makes the touch-down bearing rotate slightly.

株式会社アルバック  
規格品事業部

<https://showcase.ulvac.co.jp/ja/>

製品情報・サービス拠点・お問い合わせはこちらから



[showcase.ulvac.co.jp](https://showcase.ulvac.co.jp)

株式会社アルバック  
規格品事業部 営業部 東日本営業課  
〒253-8543  
神奈川県茅ヶ崎市萩園 2 5 0 0  
TEL:0467-89-2416

株式会社アルバック  
規格品事業部 営業部 西日本営業課  
〒532-0003  
大阪府大阪市淀川区宮原 3 - 3 - 3 1 上村ニッセイビル5F  
TEL:06-6397-2286

ULVAC ,Inc.  
Components Division

<https://showcase.ulvac.co.jp/en/>

Please contact us for products, Service Base or other Inquiries from here.



[showcase.ulvac.co.jp/en](https://showcase.ulvac.co.jp/en)

ULVAC, Inc.  
Components Division  
2500 Hagisono, Chigasaki, Kanagawa, 253-8543, Japan  
TEL: +81-467-89-2261