

G-TRAN Series
Multi-Ionization gauge Sensor Unit
Standard Type Model SH2-1
Serial Communications Type Model SH2-2
Specifications



Components Division,
ULVAC, Inc.

<http://www.ulvac.co.jp/>

1. Specifications

The SH2-1/SH2-2 has the following modes:

- ① SH2 independent mode : B-A gauge only
- ② SPU Combination mode : The Pirani vacuum gauge measuring unit (SPU) and B-A gauge combination
- ③ SAU Combination mode : The pressure sensor (SAU) and the Pirani vacuum gauge measuring unit (SPU) and B-A gauge combination
- ④ SWU Combination mode: the Pirani vacuum gauge measuring unit (SWU) and B-A gauge combination

These four modes of usage can be selected.

※SAU and SWU cannot be used at the same time

1.1. SH2-1/SH2-2 Specifications

Name	Multi-ionization gauge	
Type name	Standard Type	Serial Communications Type
Model	SH2-1	SH2-2
Connectable sensors	SH2 gauge head M-34 (NW16), M-35 (NW25), M-36(UFC070): 1 SPU Pirani vacuum gauge measuring unit: 1 (option) SAU Pressure sensor unit: 1 (option) SWU Pirani vacuum gauge measuring unit: 1 (option)	
Measurement pressure range (N ₂)	SH2 independent mode: 5×10^{-8} Pa to $1 \times 10^{+1}$ Pa	
Accuracy (N ₂)	SH2 independent mode: 5×10^{-8} Pa to $1 \times 10^{+1}$ Pa: $\pm 15\%$	
Repeatability (N ₂)	SH2 independent mode: 1×10^{-6} Pa to 1×10^{-1} Pa: $\pm 2\%$	
Measurement gas type	Indicates pressure as sensitivity for N ₂	
Emission current	1 mA (1×10^{-3} Pa or lower), 10 μ A	
DEGAS	Electron bombardment - Emission current 1 mA, grid voltage approx. 330 V	
Sampling time	50ms, 5x moving average	
Analog output	Output voltage: 0 to 10 VDC, LOG output: 0.75 V/1 decade Pressure conversion equation: $V = 7.25 + 0.75 * (\text{Log}P - 2)$ $P = 10^{\{(V - 7.25) / 0.75 + 2\}}$ * Also combined with the output voltage for setpoint adjustment (SH2-1 only)	
Update time	50 ms	
Resolution	Approx 2.5 mV	
Output error	± 20 mV	
Output impedance	1k Ω	
Control input signals	FIL ON/OFF, FIL 1/2, DEGAS ON/OFF Operates with open collector input, negative logic	
Control output signals	Sensor error, setpoint 1/2/3, emission valid, filament current abnormality Rating: 24 V _{MAX} , 50 mA _{MAX} , saturation voltage 1 V	
Serial communications		RS-232C, RS-485
Baud rate		9600/19200/38400 bps
LED display	POWER/ERROR: Power, error LED SPU: SPU/SWU Pirani vacuum gauge status indicator SAU: SAU pressure sensor status indicator FIL: B-A gauge filament status indicator SET1/2/3: Setpoint 1/2/3 LED	
Gauge head material	Filament 1: Ir/Y ₂ O ₃ -coated, Filament 2: Tungsten Others : PtC-Mo, SUS304, W, Kovar glass, Kovar/Ni plating	
Gauge head withstand pressure	B-A: $2 \times 10^{+5}$ Pa (absolute pressure) * Take the withstand pressure for flanges, clamps, and other components into account separately.	
Operating temperature range	10 to 50°C	

Operating humidity range	15% to 80% RH (no condensation)
Storage temperature	-20 to 65°C (when unpowered, no condensation)
IP code	IP30
Power supply voltage	20 to 28 VDC (ripple, noise 1% or less) *Power supply voltage at SH2 connector end Normal operation : about 8W At the time of degas : 19 W or less At power-on : 6A or lower, 4ms or less
CE standards	EN61326-2-3
Validated with SUP, SAU connected	*Less than the external I/O cable 40m *Less than the SH2-SPU cable 2m *Less than the SH2-SAU cable 2m *Less than the SH2-SWU cable 2m
I/O connector	D-sub 15-pin 2.6 mm screws
Sensor weight	Controller: Approx. 530 g, Gauge head (M-34): 80 g
External dimensions	144 x 75 x 62 mm (approximate, controller section)

1.2. SPU combination mode key specifications

Measurement pressure range	5x10 ⁻⁸ Pa to 1x10 ⁺⁴ Pa When pressure falling: Automatically switches from Pirani vacuum gauge to B-A gauge at 2x10 ⁺⁰ Pa(SPU) When pressure rising: Automatically switches from B-A gauge to Pirani vacuum gauge at 3x10 ⁺⁰ Pa(SPU) * B-A gauge measurements can be forced off with the control signal
Accuracy	Refer to the accuracy for each sensor. In the overlapping pressure region of 3 Pa to 0.4 Pa, the measured pressure for the Pirani vacuum gauge and B-A gauge is adjusted and output. * Measurements on the Pirani vacuum gauge and the B-A gauge are dependent on the gas type. Be particularly aware of the difference in pressure readings when the gauges switch.
POWER/ERROR LED state	Blue on: Operating normally Red on : SH2-1/2, SPU power supply abnormality, etc.
Control input signals (Addendum)	FIL ON/OFF, FIL 1/2, DEGAS ON/OFF Operates with open collector input, negative logic * When the FIL ON/OFF signal is low input, the B-A gauge is FIL OFF

1.3. SAU combination mode key specifications

Measurement pressure range	5x10 ⁻⁸ Pa to 1x10 ⁺⁵ Pa When pressure falling: Automatically switches from the pressure sensor to Pirani vacuum gauge at 1x10 ⁺⁴ Pa(SAU) When pressure falling: Automatically switches from Pirani vacuum gauge to B-A gauge at 2x10 ⁺⁰ Pa(SPU) When pressure rising: Automatically switches from B-A gauge to Pirani vacuum gauge at 3x10 ⁺⁰ Pa(SPU) When pressure rising: Automatically switches from Pirani vacuum gauge to pressure sensor at 1x10 ⁺⁴ Pa(SAU) * B-A gauge measurements can be forced off with the control signal
Accuracy	Refer to the accuracy for each sensor. In the overlapping pressure region of 3 Pa to 0.4 Pa, the measured pressure for the Pirani vacuum gauge and B-A gauge is adjusted and output. * The pressure sensor measures at gauge pressure and the Pirani sensor measures as absolute pressure, so a margin of error occurs from altitude and air pressure. * Measurements on the Pirani vacuum gauge and the B-A gauge are dependent on the gas type. Be particularly aware of the difference in pressure readings when the gauges switch.

POWER/ERROR LED state	Blue on: Operating normally Red on : SH2-1/2, SPU, or SAU power supply abnormality, etc.
Control input signals	FIL ON/OFF, FIL 1/2, DEGAS ON/OFF Operates with open collector input, negative logic * When the FIL ON/OFF signal is low input, the B-A gauge is FIL OFF

1.4. SWU combination mode key specifications

Measurement pressure range	5x10 ⁻⁸ Pa to 1x10 ⁺⁵ Pa When pressure falling: Automatically switches from Pirani vacuum gauge to B-A gauge at 2x10 ⁺⁰ Pa(SWU) When pressure rising: Automatically switches from B-A gauge to Pirani vacuum gauge at 3x10 ⁺⁰ Pa(SWU) * B-A gauge measurements can be forced off with the control signal
Accuracy	Refer to the accuracy for each sensor. In the overlapping pressure region of 3 Pa to 0.4 Pa, the measured pressure for the Pirani vacuum gauge and B-A gauge is adjusted and output. * Measurements on the Pirani vacuum gauge and the B-A gauge are dependent on the gas type. Be particularly aware of the difference in pressure readings when the gauges switch.
POWER/ERROR LED state	Blue on: Operating normally Red on : SH2-1/2, SWU power supply abnormality, etc.
Control input signals	FIL ON/OFF, FIL 1/2, DEGAS ON/OFF Operates with open collector input, negative logic * When the FIL ON/OFF signal is low input, the B-A gauge is FIL OFF

1.5. Separately ordered products

SH2 Sensor	M-34(NW16), M-35(NW25), M-36(UFC070)	
SH2 connector	D-sub 15-pin connector (female, 2.6 mm screws)	
Unit cable GUC-P	0.5m, 1m, 2m	
Unit cable GUC-A	0.5m, 1m, 2m * 0.5m cable is connected to SAU.	
Display unit	1CH	Model ISG1 (24 VDC power supply)
	4CH	Model IM1R1 (24 VDC power supply)
		Model IM2R1 (100 VAC power supply)
Display cable	SH2-display unit cable 2 m, 5 m, 10 m, 15 m, 20 m, 25 m, 30 m, 35 m, 40 m	
JCSS Calibration certificate		
Calibration certificate		
Test results certificate		
Traceability certificate		

1.6. Accessory

Multi-ionization gauge SH2-1/2 unit	1
Quick Manual	1 set

1.7. Option

SPU Pirani vacuum gauge measuring unit	(option)
WP Pirani vacuum gauge head	(option)
SAU Pressure sensor	(option)
SWU Pirani vacuum gauge measuring unit	(option)
SWP Pirani vacuum gauge head	(option)
Unit cable GUC-P	(option)
Unit cable GUC-A	(option)

1.8. Connection with External Devices

SH2-1 Standard Type (D-sub 15-pin male M2.6mm screws)

Terminal number*	Sensor	Function
1	Power supply	Power supply to drive this unit
2	Sensor error	Outputs the pressure protection signal or a signal during an error such as when there is a filament break
3	Setpoint 1	Outputs a signal during setpoint 1 operation
4	Emission valid	Outputs a signal when emission current is normal
5	FIL ON/OFF	Input a signal to turn the filament on or off * FIL ON signal in SH2 independent mode * FIL OFF signal in combination mode
6	FIL 1/2	Input a signal when selecting FIL 2
7	FIL power monitor	Outputs a signal when the FIL power exceeds the threshold
8	Pressure signal/setpoint setting output	Outputs the pressure signal and the setpoint setting output
9	Power supply GND	Ground for the power supply that drives this unit
10	Signal GND	Output signal ground
11	Setpoint 2	Outputs a signal during setpoint 2 operation
13	DEGAS ON/OFF	Input a signal during DEGAS ON
14	Setpoint 3	Outputs a signal during setpoint 3 operation
15	Signal GND	Output signal ground
Case	FG	Frame ground

SH2-2 Serial Communications Type (D-sub 15-pin male M2.6mm screws)

Terminal number*	Sensor	Function
1	Power supply	Power supply to drive this unit
4	RS-232C Rx/D	RS-232C Rx/D
5	Terminal resistance for RS-485	Terminal resistance for RS-485, connect with pin 13
6	RS-232C Tx/D	RS-232C Tx/D
8	Analog output	Outputs the pressure signal
9	Power supply GND	Ground for the power supply that drives this unit
10	RS-485-	RS-485-
12	RS-485+	RS-485+
13	RS-485 (for terminal resistance connection)	Terminal resistance for RS-485, connect with pin 5
14	RS-232C GND	RS-232C ground
15	GND	Output signal ground
Case	FG	Frame ground

2. Analog Output (SH2-1/SH2-2)

This unit outputs the measured pressure as a 0 to 10 VDC voltage signal.

I/O connector: pin 8 (analog output+) - pin 15 (GND)

2.1. Pressure conversion equation

Convert the analog output to pressure with the following equation.

$$P = 10^{\{ (V - 7.25) / 0.75 + C \}} \quad \Leftrightarrow \text{Log}P = C/25 + 0.75 \times$$

P: Pressure (Pa) V: Output voltage (V)

Pressure Unit	C (Pressure unit dependent)
Pa	2
Torr	-0.125
mbar	0

2.2. SH2 independent mode analog output

The analog output that can occur in several states during measurements is shown in Table 2-1 Analog output states.

Table 2-1 Analog output states

Operating state	Analog output voltage
Filament off	9.9 V or higher
During normal measurements	Voltage corresponding to the measured pressure 0.27 to 6.5 V
SH2 error(Errors such as a filament break)	9.9 V or higher
Abnormal power supply voltage, sensor malfunction, etc.	0.1 V or less

2.3. SPU combination mode analog output

The analog output that can occur in several states during measurements is shown in Table 2-2 Measurement value output states.

Table 2-2 Measurement value output states

Operating state	Analog output voltage
During normal measurements	Voltage corresponding to the measured pressure 0.27 to 8.75 V
1×10^4 Pa or higher	8.75 V
SH2 error(Errors such as a filament break)	Voltage corresponding to the measured by SPU 5 V to 8.75V
B-A gauge FIL OFF	Voltage corresponding to the measured by SPU 5 V to 8.75V
SPU error(Errors such as a filament break)	9.9 V or higher
Power supply voltage abnormality, sensor unit fault, etc.	0.1 V or less

* Error is output even if SPU error. However, the B-A gauge error is cleared by turning FIL off.

2.4. SAU combination mode analog output

The analog output that can occur in several states during measurements is shown in Table 2-3.

Table 2-3 Analog output states

Operating state	Analog output voltage
During normal measurements	Voltage corresponding to the measured pressure 0.27 to 9.5 V
Atmospheric pressure or higher	9.5 V or higher
SH2 error (Errors such as a filament break)	Voltage corresponding to the measured by SAU and SPU 5 V to 9.5 V
B-A gauge FIL OFF	Voltage corresponding to the measured by SAU and SPU 5 V to 9.5 V
SPU error (Errors such as a filament break)	Voltage corresponding to the measured by SAU 8.677 V to 9.5V
SAU error	9.9 V or higher
Power supply voltage abnormality, sensor unit fault, etc.	0.1 V or less

* Error is output even if a SAU or SPU error.

However, the B-A gauge error is cleared by turning FIL off.

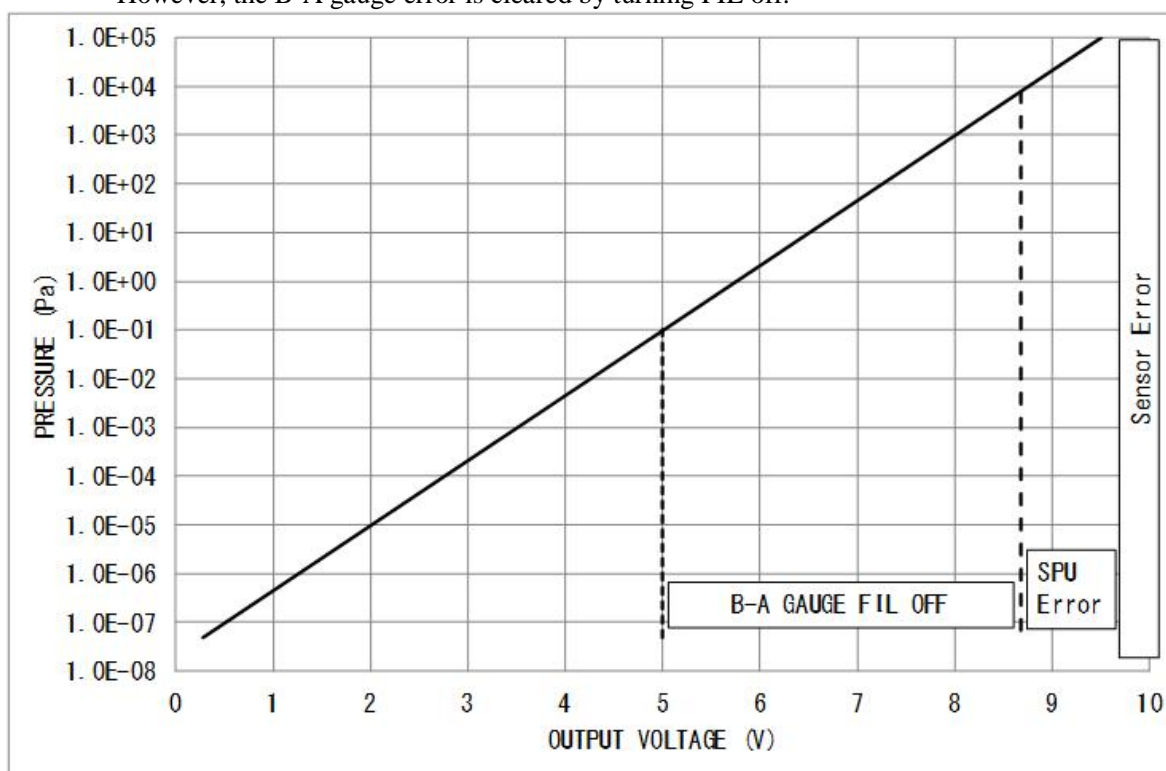

※SAU combination mode analog output

2.5. SWU combination mode analog output

The analog output that can occur in several states during measurements is shown in Table 2-4 Measurement value output states.

Table 2-4 Measurement value output states

Operating state	Analog output voltage
During normal measurements	Voltage corresponding to the measured pressure 0.27 to 9.5 V
1×10^5 Pa or higher	9.5 V
SH2 error(Errors such as a filament break)	Voltage corresponding to the measured by SWU 5 V to 9.5V
B-A gauge FIL OFF	Voltage corresponding to the measured by SWU 5 V to 9.5V
SWU error(Errors such as a filament break)	9.9 V or higher
Power supply voltage abnormality, sensor unit fault, etc.	0.1 V or less

* Error is output even if SWU error. However, the B-A gauge error is cleared by turning FIL off.

2.6. Simple conversion tables

Pressure (Pa)	Analog output (V)	Values after the decimal point	Voltage difference
5.0E-08	0.274	1.0E-N	0.000
1.0E-07	0.500	1.5E-N	0.132
1.0E-06	1.250	2.0E-N	0.226
1.0E-05	2.000	2.5E-N	0.298
1.0E-04	2.750	3.0E-N	0.358
1.0E-03	3.500	3.5E-N	0.408
1.0E-02	4.250	4.0E-N	0.452
1.0E-01	5.000	4.5E-N	0.490
1.0E+00	5.750	5.0E-N	0.524
1.0E+01	6.500	5.5E-N	0.555
1.0E+02	7.250	6.0E-N	0.584
1.0E+03	8.000	6.5E-N	0.610
1.0E+04	8.750	7.0E-N	0.634
1.0E+05	9.500	7.5E-N	0.656
		8.0E-N	0.677
		8.5E-N	0.697
		9.0E-N	0.716
		9.5E-N	0.733
		10.0E-N	0.750

To find the analog output voltage when the pressure is 5E+1 Pa.

From the left table, voltage when 1E+1 Pa: 6.5 V

From the right table, voltage when 5E-N Pa: 0.524 V

Therefore, $6.5 \text{ V} + 0.524 \text{ V} = 7.024 \text{ V}$.

3. Control Signals

3.1. Control output signals (SH2-1 Standard Type only) Photocoupler rating: 30 V_{MAX}, 50 mA_{MAX}, 70 mW

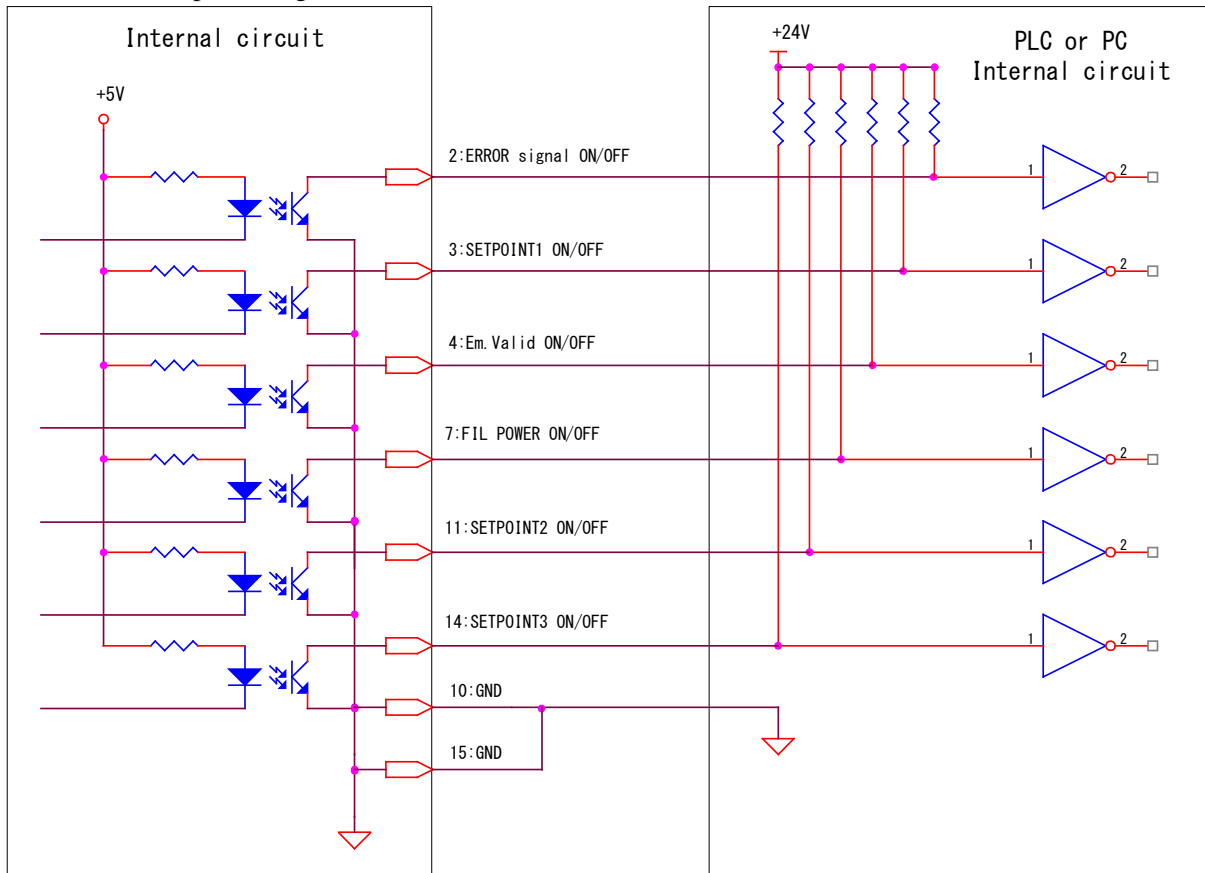

Figure 3-1 SH2-1 output signal internal circuit diagram

3.2. Control input signals (SH2-1 only)

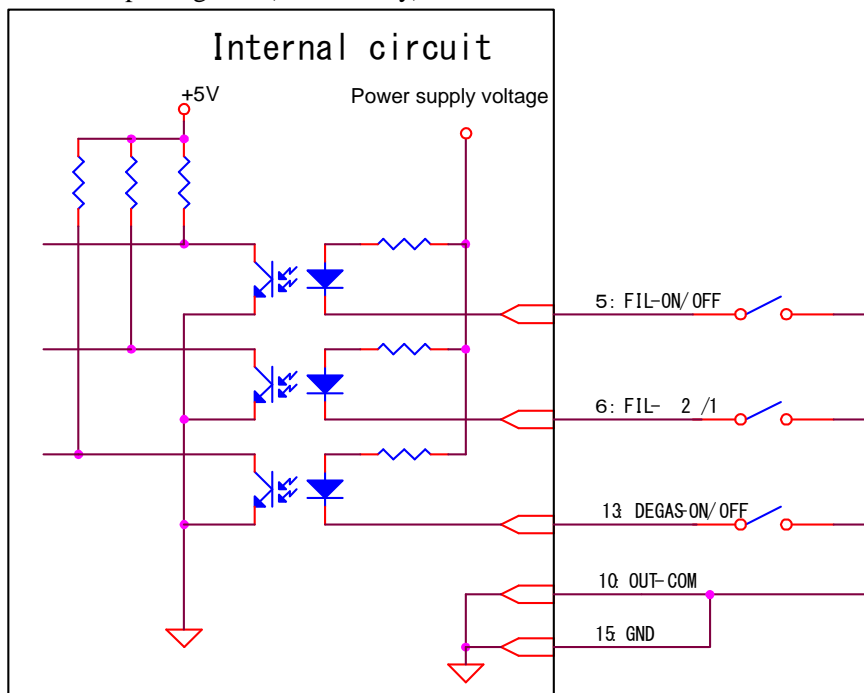

Figure 3-2 SH2-1 input signal internal circuit diagram

4. Using Serial Communications (SH2-2 Serial Communications Type)

4.1. Serial communications specification

RS-485	RS-232C
2-wire	
Half duplex	
Asynchronous	
ASCII code	
Data bit length 8 bits	
Stop bit 1 bit	
No parity	
Maximum cable length 30 m *1	Maximum cable length 15 m
Maximum connections 32 (including host)	Maximum connections 1
9600/19200/38400 bps	9600/19200/38400 bps

4.2. Settings

4.2.1. Wiring diagram

4.2.1.1. RS-232C wiring diagram

The diagram below shows an example RS-232C connection. The host side is D-sub 9-pin

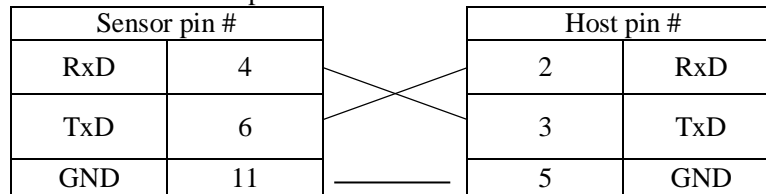

4.2.1.2. RS-485 no terminal resistance (example)

For RS-485 wiring, the diagram below describes the National Instruments USB Serial Interface USB-485 as an example.

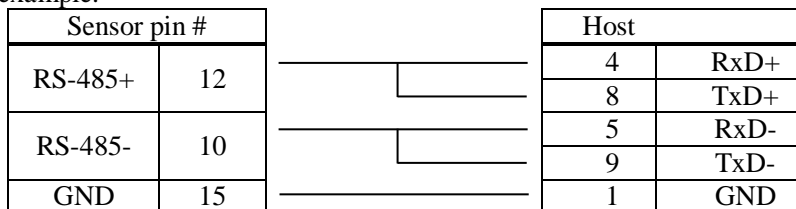

4.2.1.3. RS-485 with terminal resistance (example)

For RS-485 wiring, the diagram below describes the National Instruments USB Serial Interface USB-485 as an example.

When there are many RS-485 connections, when the total length of the connection cables is over 15 m, or when there are frequent communications errors, attach a terminal resistor to the terminal device.

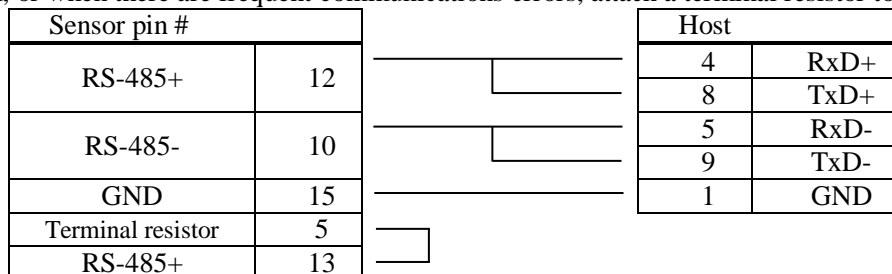

4.3. Basic data format

The basic data format for sending and receiving data is described below.

:	AD0	AD1	CMD	D0	Dn	SH	SL	CHKH	CHKL	CR
---	-----	-----	-----	----	-------	----	----	----	------	------	----

: Colon

- AD0 Device address, upper 4 bits (uppercase characters: 0 to 9)
- AD1 Device address, lower 4 bits (uppercase characters: 0 to 9)
- CMD Command (case sensitive)
- D0 Data <4 bits> (uppercase characters: 0 to 9, A to F)
- Dn Data <4 bits> (uppercase characters: 0 to 9, A to F)
- SH Status upper 4 bits
- SL Status lower 4 bits
- CHKH Checksum upper 4 bits (upper case characters: 0 to 9, A to F)
- CHKL Checksum lower 4 bits (upper case characters: 0 to 9, A to F)
- CR Carriage return

- Commands are composed of upper case and lower case alphanumeric characters.
- The checksum is an exclusive OR (XOR) of AD0 to SL. Convert with hexadecimal ASCII codes.

4.3.1. Command list

Command	Description	Command	Description
D	Read measurement value, status	1R	Read setpoint 1 setting
ATM	Adjust atmospheric pressure	2R	Read setpoint 2 setting
SR	Read status	1W	Write setpoint 1 setting
SW	Write status	2W	Write setpoint 2 setting
FIL	Check filament current value	ERR	Check error details
T	Model, software version		

4.4. Command : Read measurement value, status

Command	:	AD0	AD1	D	CHKH	CHKL	CR
---------	---	-----	-----	---	------	------	----

Sensor -> PC response format

:	AD0	AD1	D	X	.	X	X	E	±	X	X	SH	SL	CHK H	CHK L	CR
---	-----	-----	---	---	---	---	---	---	---	---	---	----	----	----------	----------	----

- The measured pressure value goes in "X.XXE±XX".
 Example 1: 3.00E+03 -> 3.00x10⁺³
 Example 2: 5.00E+00 -> 5.00x10⁺⁰
 Example 3: 4.00E-01 -> 4.00x10⁻¹
- "E.EEE+EE" response: Sensor error
- "F.FFE+FF" response: SH2 independent mode only, over measurement range, filament off
- For status "SH" and "SL", see the separate section.

5. Warranty

This product has been shipped after undergoing an extensive in-house inspection. However, in the event a failure occurs that ULVAC Inc. is responsible for, such as a manufacturing defect or accident during shipment, please inquire with the Components Division of ULVAC Inc. or the nearest sales office or dealer regarding repairs. The product will be repaired or replaced at no charge.

Subject to warranty

- 1) Pressure sensor unit
- 2) Gauge head immediately after delivery

Duration of guarantee

Within one year of the shipping date

Warranty range

- 1) Products damaged by problems during delivery, shipping.
- 2) Direct export transaction: Product, which has damage, caused by a failure on delivery. The warrantee scope shall confirm to the new INCOTERMS.
- 3) Products that do not meet key specifications even when used within the conditions in the key specifications including measurement pressure, operating temperature range, and power supply used.

Response procedure

- 1) Domestic business in Japan: ULVAC send a replacement or Buyer return the defective items to ULVAC, Inc. or to the local ULVAC representatives for repair. If field service is required, Buyer shall ask ULVAC, Inc. or the local ULVAC representatives.
- 2) Direct export transaction: ULVAC send a replacement or Buyer return the defective items to ULVAC, Inc. or to the local ULVAC representatives for repair. Return charge shall be paid by Buyer.

Disclaimer

- 1) Failure occurred after expiration of warranty period
- 2) Failure caused by force majeure, such as fire, storm and flood damage, earthquake, lightning strike, war etc
- 3) Failure occurred due to carelessness handling or faulty usage
- 4) Products remodeled, disassembled or repaired without ULVAC's acceptance
- 5) Failure occurred under abnormal environment, such as intense electromagnetic field, radiation, high-temperature, high-humidity, flammable gases, corrosive gases, dust etc.
- 6) Failure occurred by noise
- 7) Product deficiency or secondary damnification occurred to Buyer, from law suit to ULVAC by third party for patent infringement.
- 8) Sensor head being used (expiration of life, measurement error, etc.)
- 9) Sensor head cable in use (cable burnout due to improper installation, poor contact, etc.)

Others

- 1) In case, special agreement or memorandum for specifications is made individually, the descriptions are prior to this article "13 Product Warranty".
- 2) Buyer shall inform ULVAC when this product is exported out of Japan. In the meantime, Buyer shall take necessary procedures according to Foreign Exchange and Foreign Trade Law.
- 3) As for the question and consultation, Buyer shall check the model and serial number and ask the local representative or ULVAC, Inc.
- 4) The content of this document is subject to change without notice in future.

6. Related drawings

6.1. SH2-1/SH2-2, SPU, SAU connection diagram

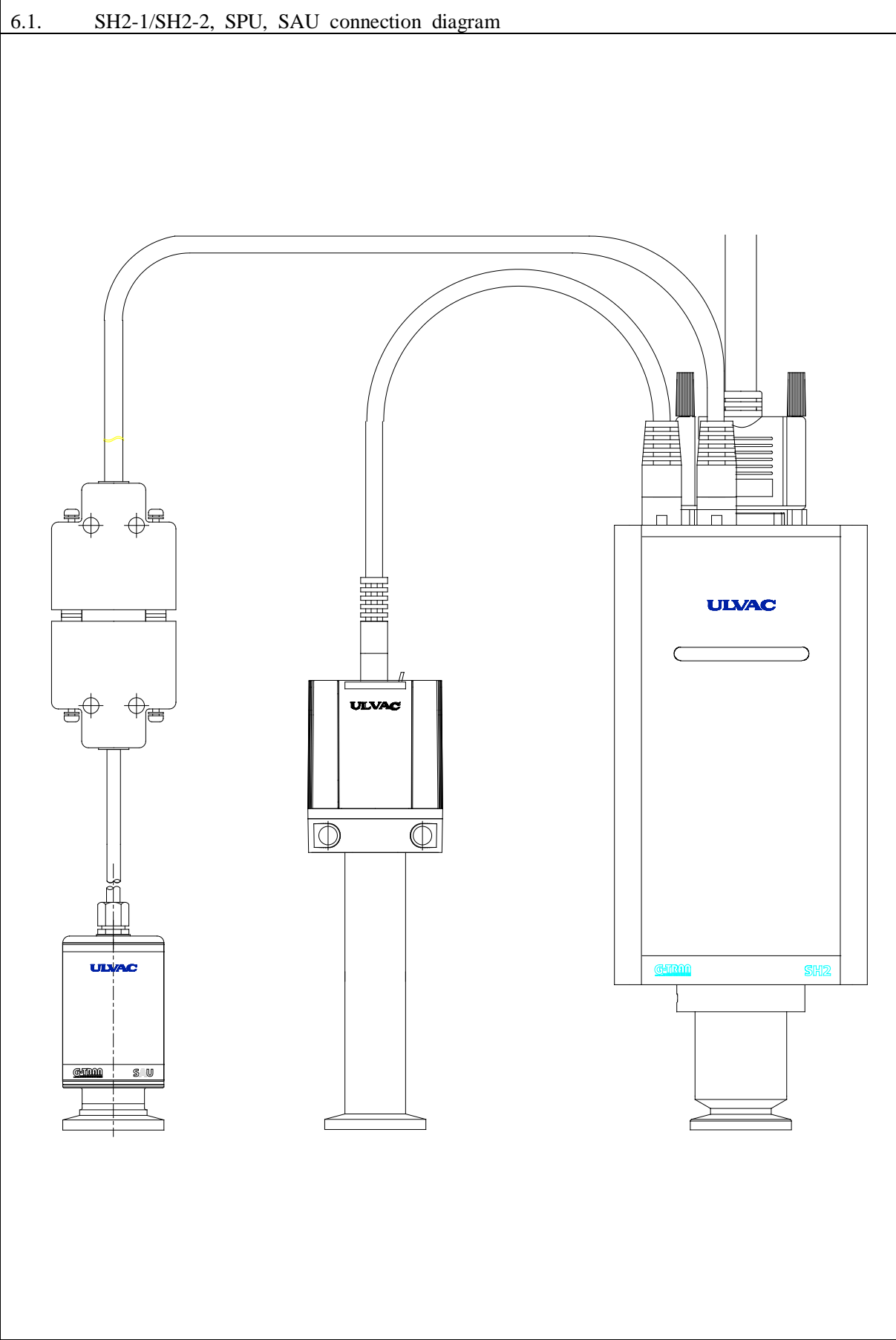

6.2. SH2-1/SH2-2, SWU connection diagram

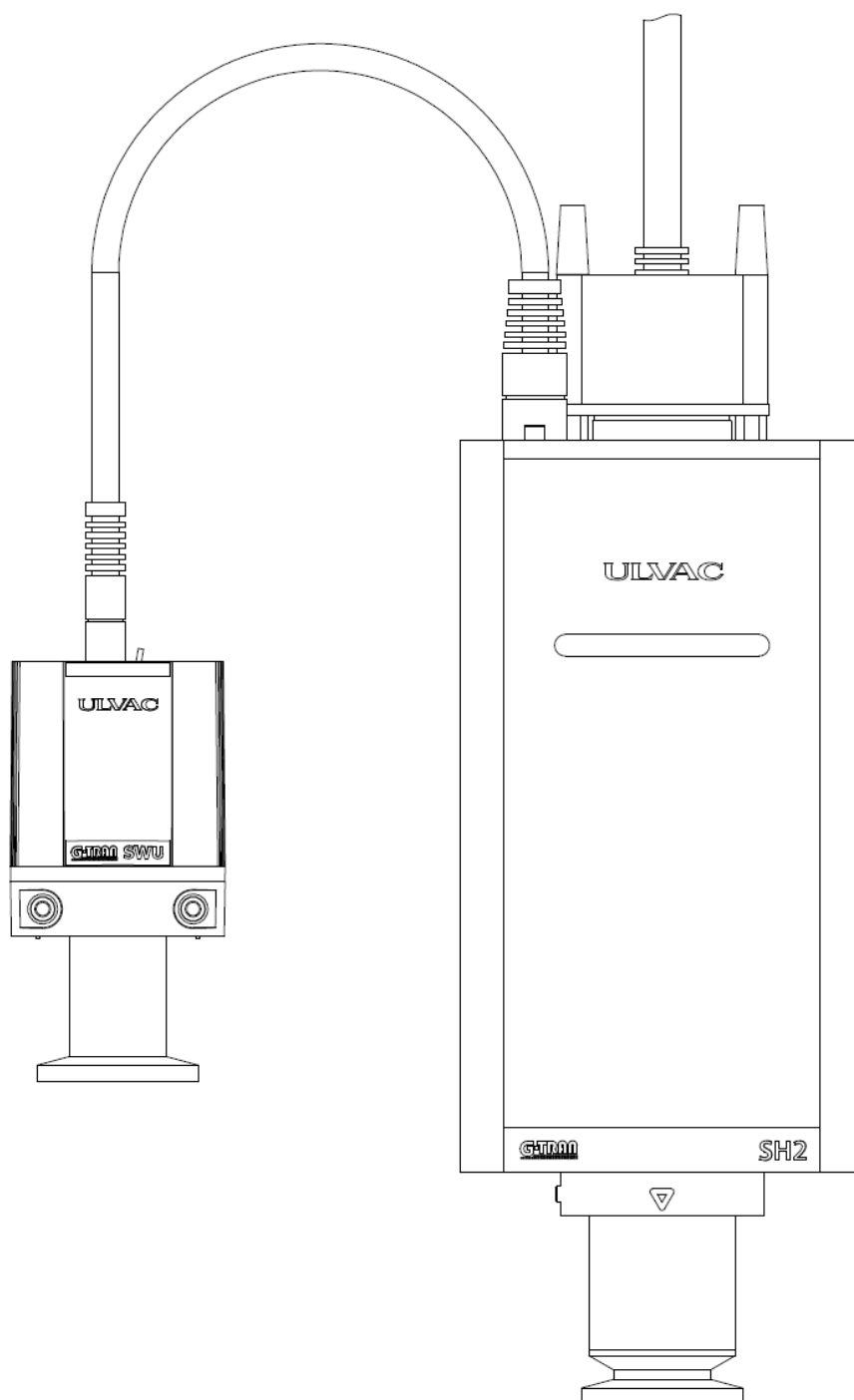

6.3. SH2-1 dimensions

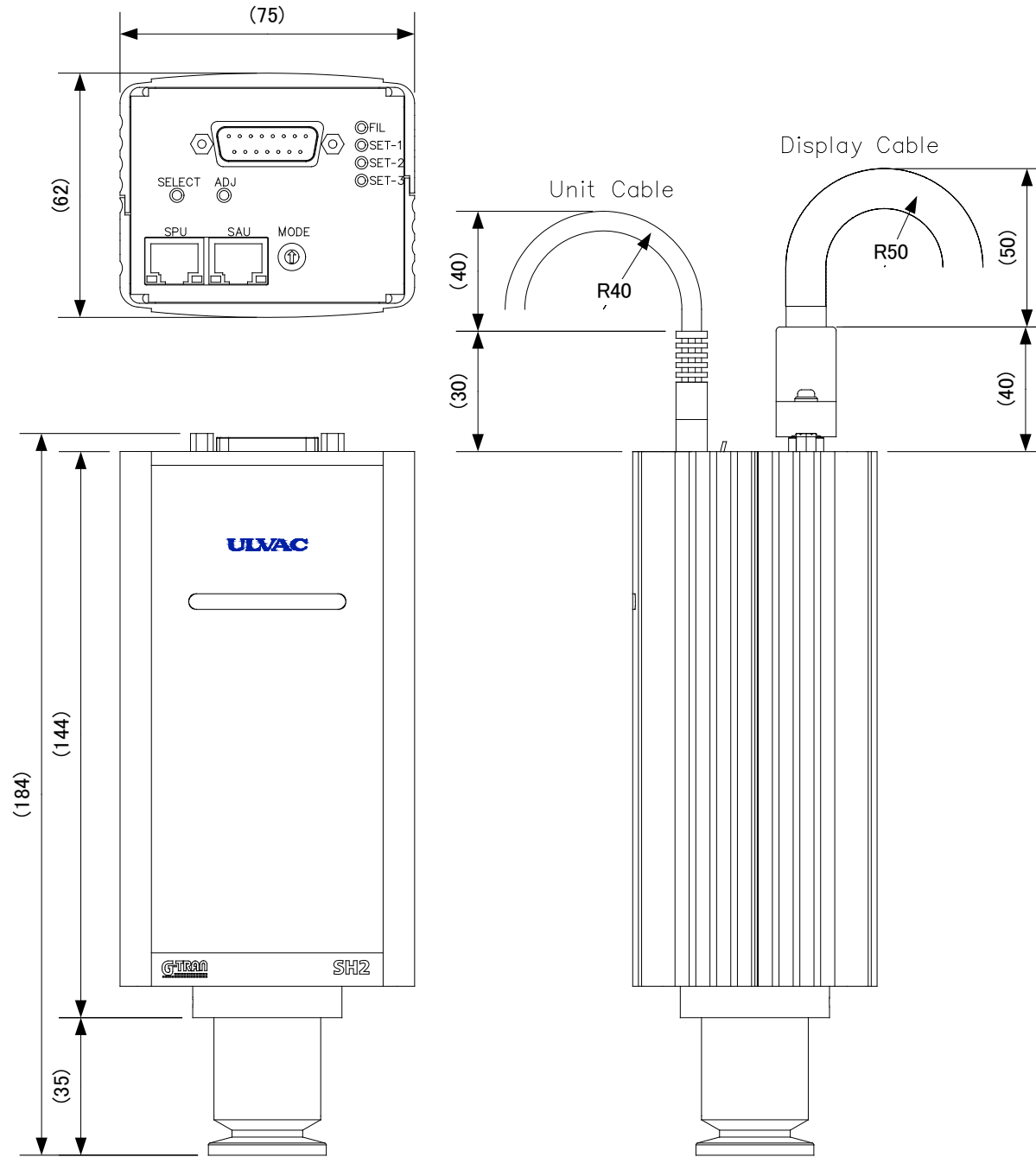

6.4. SH2-2 dimensions

