

Quick Start Manual for OIL SEALED ROTARY VACUUM PUMP VD151,VD201

«For safe use»
 This quick start manual is prepared to help users to quickly understand the product's operating method and display content. Please read the instruction manual beforehand for detailed usage, caution on product use, and safety information to use the pump correctly. You can download the instruction manual from Ulvac website. <https://showcase.ulvac.co.jp/ja>

1. Setting

Upon delivery of this product, check first that the delivered is exactly what you have ordered and there is no break or damage through transport or the like.

Oil one time portion	ULVOIL R-72	1set
Quick Start Manual		1copy

2. System Flow

Power supply is required. And you prepare wiring, safety circuit and exhaust processing equipment, etc.

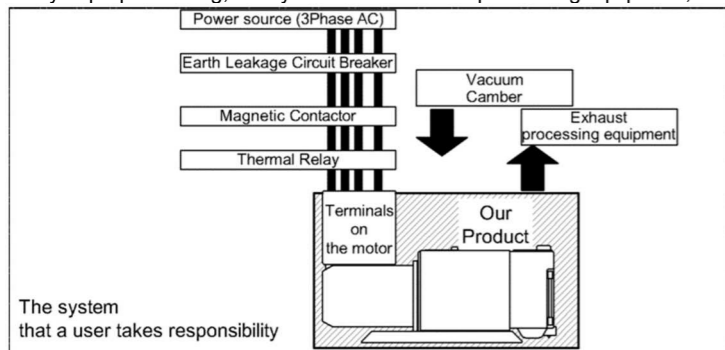

Location of vacuum pump in host device

3. Ambient Condition for Storage, Install and Operation

As precise clearances are provided with this machine, be sure to fulfill the following for its storage, install and operation;

- ① Ambient temperature and humidity for storage : -10°C to 50°C, less than 95%RH
- ② Ambient temperature and humidity for operation : 4°C to 40°C, less than 80%RH
- ③ Height (for both storage and operation) : Lower than 1,000 meters altitude
- ④ External vibration (for both storage and operation) : Vibration acceleration less than 114dB (0.5G)
- ⑤ Miscellaneous (for both storage and operation)
 - a. There shall be no corrosion behavior or explosive gas.
 - b. There shall be no freeze or dew formation.
 - c. There shall be no dust.
 - d. It shall be in house.
 - e. Another pump shall not be put on the Pump. The Pump shall not be laid down nor put touching its motor edge face or oil gauge edge face with the ground.
 - f. There shall be no direct sun beam.
 - g. Heat source shall be put away from the Pump.

Install the machine horizontal to a place where there are less dust and humidity. Make a layout taking into consideration of works such as setting, removal, check, cleaning and so on.

4. Inlet port Piping

1) Before connecting the piping to the pump, clean the vacuum chamber, piping, vacuum valve, etc. well. If they are contaminated, the ultimate pressure may be higher or a longer time may be required to reduce pressure to the specified level. Wear a pair of gloves to touch any vacuum section. Do not touch with the bare hand.

2) Use the KF25 (JIS B 8365 -Dimensions of Clamped - type Vacuum Couplings-)for connection between the pump Inlet and the piping. It is recommended to use piping with bellows so that the vibration of the pump is not transmitted to the vacuum chamber.

3) Provide a vacuum valve, vacuum gauge and vent valve between the vacuum chamber and pump, as shown in Fig.

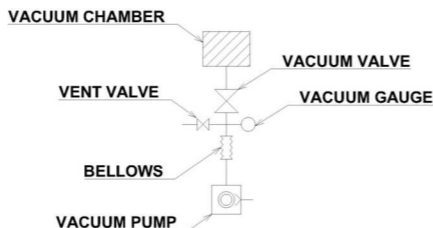

5. Exhaust Connection

Use the "G1" (JIS B0202-Parallel pipe threads-) for connection between the Outlet of the pump and the duct piping. It is recommended to provide an oil mist trap to reduce oil consumption and to trap oil mist.

6. Lubrication

Remove the oil filling plug and fill the pump with oil until the oil level comes between the two level lines of the oil level gauge (Refer to the "Fig. Lubrication and oil level indication").

The pump is operable if the oil level is between the two level lines of the oil level gauge during operation.

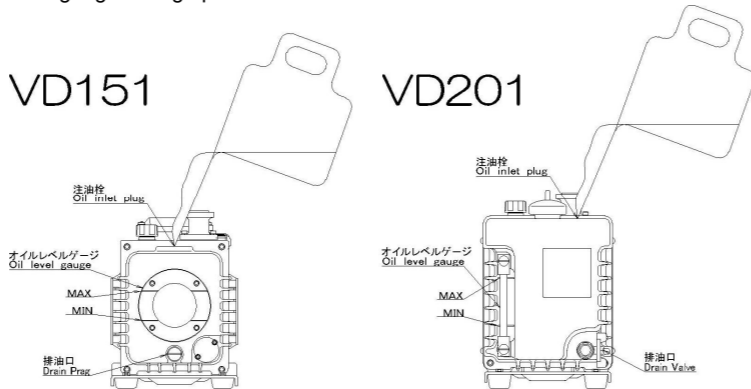

Lubrication and oil level indication

7. Electrical Connection

Conduct the electrical connection referring to the Fig. and Table. Without changing motor, it is possible to run the Pumps both with 200V and 400V class utilities by changing wire connection in the motor terminal box because multi voltage motor, for both 200V and 400V classes, is used for this pump.

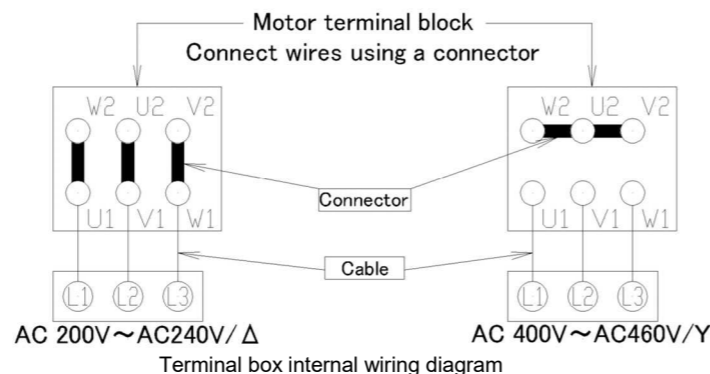

Terminal box internal wiring diagram

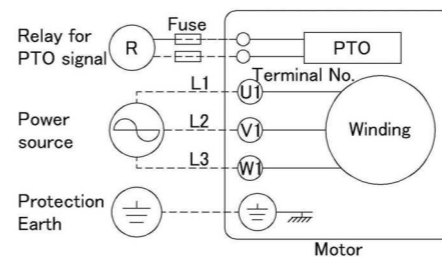

Electrical wiring diagram

This motor incorporates a temperature sensor (PTO : which opens at 150°C) and leader wires are arranged in the terminal box. Use these wires to take out the signal wire.

Connect the temperature sensor (PTO) as shown in Fig. 7. The specifications of the temperature sensor are shown in Table

Type	Operating Principle	Operating Curve	Cut-off(A)
Normally closed thermostat PTO	Bimetallic strip, indirectly heated, with normally closed (N/C) contact		2.5A at 250V with cos φ 0.4

N.R.T.: Nominal running temperature of the PTO

8. Operation

8-1. Operation Start

Before starting the pump, check the following again.

- 1) Piping and wire connection are completed.
- 2) Checking the oil level Ensure that the oil level is between the two level lines on the oil level gauge.
- 3) Checking the rotating direction Close the vacuum valve on the Inlet side, open the vent valve, and run the pump for two to three seconds to check the rotating direction of the motor. If the motor is rotating in the correct direction (Counterclockwise as viewed from the motor side), pressure will lower. If it is reversed, interchange two of the three wires shown in Fig. Electrical wiring diagram.
- 4) After checking (1), (2) and (3) above, close the vent valve and run the pump. Here, ensure that the vacuum gauge between the vacuum valve and the pump indicates a pressure close to the ultimate pressure.

8-2. Operation Stop

- 1) Close the vacuum valve on the Inlet side, open the vent valve to vent the pump, and shut down the pump.
- 2) After shutdown, open the vent valve to vent the pump to atmospheric pressure.

8-3. Gas Ballast Function

This product is installed with the Gas ballast function as standard. It is applicable to breathe in the condensed gas such as the steam and solution vapor.

If introduced the air or dry nitrogen through the Gas ballast valve just before the Pump compression process, the condensed gas is not liquefied but exhausted with the air through the Exhaust valve.

8-4. Vacuum Pump Oil For cold district

Starting the Pump operation might become difficult in winter season or in the cold district.

This is the overload phenomenon caused by increased viscosity of the pump oil. To make sure, you should confirm that the capacity of the motor overload protective device conforms to the motor rated value, the pump is not broken and the cable does not have abnormality. Then, warm up the Pump oil or replace the oil with the Vacuum pump oil ULVOIL R-4 having lower viscosity. Recommended type of oil:

- 1) ULVOIL R-72 (standard oil)
- 2) ULVOIL R-42 (Cold area or winter time)

8-5. Oil mist trap (Optional)

The oil mist trap can be mounted to trap the oil mist discharged from the pump.

The TMX-1 model is for the VD151/VD201. The trap with adapter can be set on the pump instead of the original exhaust pipe at the outlet.

- 1) At the outlet of the pump, remove the original exhaust pipe.
- 2) You assemble the adapter and TMX-1 to establish the pump.
- 3) Between the adapter and TMX-1, put the O-ring(G85). Four small screws and washers fix adapter and TMX-1. * When the adapter is attached to the TMX-1, please remove the baffle inside the trap.
- 4) Between the pump and adapter, put the O-ring(G30). Please set up the exhaust vent.

For more information, please see the instructions OIL MIST TRAPS.

オイルミストトラップ TMX-1 Oil mist trap TMX-1

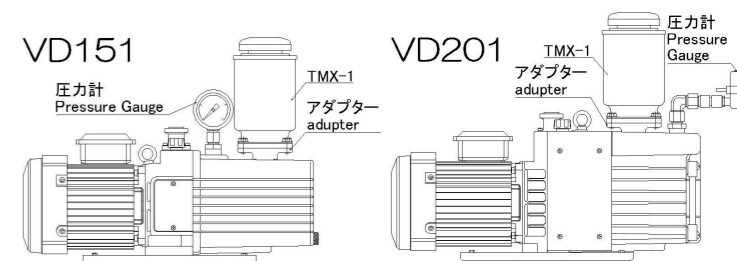
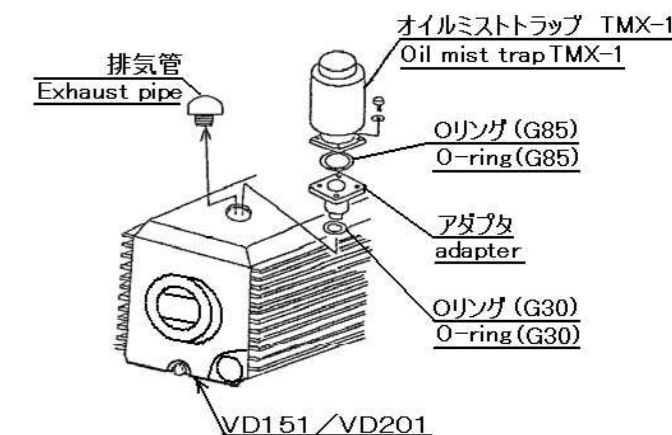
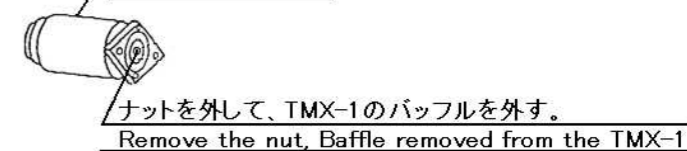

When having mounted oil mist trap and adapter

ULVAC SHOWCASE



You can download the instruction manual from here.

ULVAC, Inc. Components Division
 2500 Hagisono, Chigasaki, Kanagawa, Japan 253-8543
<http://www.ulvac.co.jp/>