

Quick Start Manual for Mechanical Booster Pump

PRC-003A, PRC-006A, PRC-012A, PRC-018A

« For safe use »

This quick start manual is prepared to help users to quickly understand the product's operating method and display content. Please read the instruction manual beforehand for detailed usage, caution on product use, and safety information to use the pump correctly. You can download the instruction manual from Ulvac website. <https://showcase.ulvac.co.jp/ja>

1. Setting

Upon delivery of this product, check first that the delivered is exactly what you have ordered and there is no break or damage through transport or the like.

Part name	Specification	Quantit	Remarks
Oil one time portion	ULVOIL R-42	1 set	For the consumed amount, refer to the specification table.
Instruction manual	English	1 copy	—

2. System Flow

Cooling water and power supply is required. And you prepare wiring, safety circuit and exhaust processing equipment, etc.

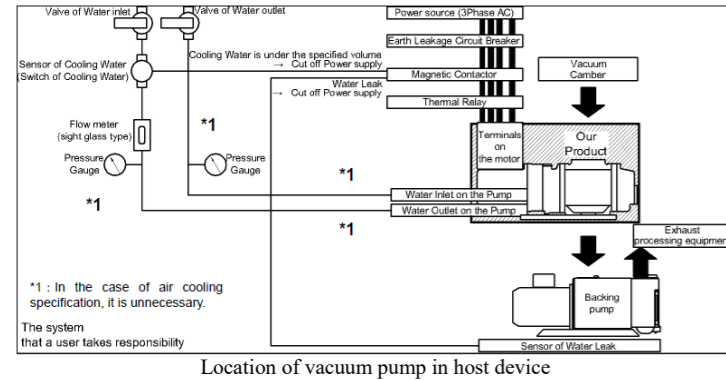

3. Ambient Condition for Storage, Install and Operation

As precise clearances are provided with this machine, be sure to fulfill the following for its storage, install and operation;

- ① Ambient temperature and humidity for storage : -30°C to 60°C, less than 95%RH
- ② Ambient temperature and humidity for operation : 10°C to 40°C, less than 80%RH
- ③ Height (for both storage and operation) : Lower than 1,000 meters altitude
- ④ External vibration (for both storage and operation) : Vibration acceleration less than 114dB (0.5G)
- ⑤ Miscellaneous (for both storage and operation)
 - a. There shall be no corrosion behavior or explosive gas.
 - b. There shall be no freeze or dew formation.
 - c. There shall be no dust.
 - d. It shall be in house.
 - e. Another pump shall not be put on the Pump.
 - f. The Pump shall not be laid down nor put touching its motor edge face or oil gauge edge face with the ground.
 - g. There shall be no direct sun beam.
 - h. Heat source shall be put away from the Pump.

MODEL	Base fixing hole size	Bolt size
PRC-003A	4-φ12	M10×20 mm or more
PRC-006A	4-φ14	M12×20 mm or more
PRC-012A	4-φ15	M12×20 mm or more
PRC-018A	4-φ15	M12×20 mm or more

* Refer to the instruction manual for the dimensions of the base fixing holes.

4. Lubrication

Supply the lubrication oil by specified volume through the oiling port on the Gear cover. It takes approximately one minute that the lubrication oil fully spreads out. Check the oil volume by the Oil level gauge after the lubrication got stabled and add the oil if it was under the specified level as far as the oil gets stabled on the upper limit level.

MODEL	Place	In oiling	During operating
PRC-A Series	Oil level gauge on the Cover of gear side	Put the oil up to the upper limit level.	Oil level shall be available between level lines of 2 pieces of the oil gauge.

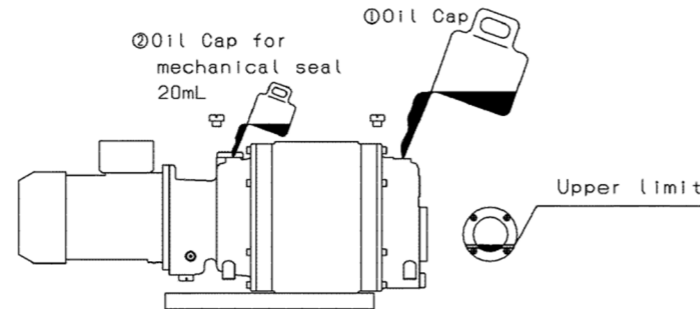

* For refueling the mechanical seal, refer to the instruction manual.

5. Water Piping

This pump, cooling water is required (Air-cooled type, cooling water is not required). Connect piping to the Cooling water inlet / outlet using care not to mistake the port.

- Primary side pressure : 0.3 MPaG or less
- Inlet/outlet differential : 0.01 MPaG or more
- Temperature : 5~30 °C

Model	Motor output (kW)	Rated current value (A)		
		200V, 50Hz	200V, 60Hz	220V, 60Hz
PRC-003A	0.75	3.5	3.3	3.2
PRC-006A	2.2	9.9	9.3	8.7
PRC-012A	3.7	15.5	14.9	13.8
PRC-018A	5.5	22.0	21.0	20.0

6. Inlet port Piping

Use the flange for connection between the pump Inlet and the piping. Provide a vacuum valve, vacuum gauge and vent valve between the vacuum chamber and pump, as shown in Fig. Evacuation by mechanical booster pump (example).

MODEL	Flange at the pipe
PRC-003A	VF80
PRC-006A	VF80
PRC-012A	VF100
PRC-018A	VF150

JIS B 2290:1998
Vacuum technology-Flange dimensions; Attachment book (Reference)
Flange dimensions for maintenance

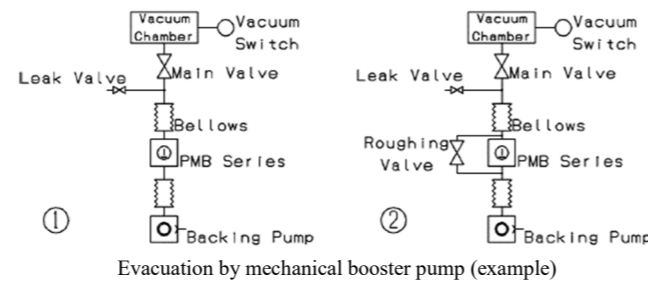

7. Outlet port Piping

Use the flange for connection between the pump Outlet and the piping.

MODEL	Flange at the pipe
PRC-003A	VG80
PRC-006A	VG80
PRC-012A	VG80
PRC-018A	VG100

JIS B 2290:1998
Vacuum technology-Flange dimensions; Attachment book (Reference)
Flange dimensions for maintenance

8. Electrical Connection

Refer to the figure below for motor connection.

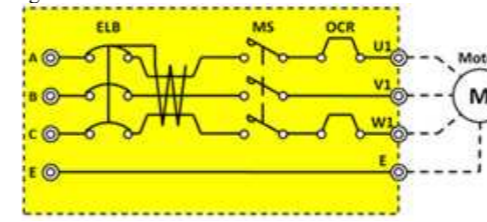

Recommended connection diagram

Motor terminal board	Standard	U	V	W	E
Motor controller terminal board	Option	R	S	T	GND
		↑	↑	↑	↑
Power		R	S	T	GND

* For motor control equipment (inverter), refer to the following.

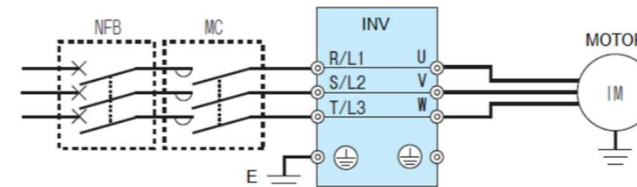

- Wire R, S, T to the primary side.
- Wire U, V, W to the motor side.

9. Operation

9-1. Operation Start

Follow the procedure (1) - (4) below to start operation of the Pump unit.

- (1) Check and ensure that the piping and cable connection is completed.
- (2) Check the lubrication oil level.
- (3) Check the Cooling water.
 - Ensure that the Cooling water is flowing.
 - Check and ensure also that there is no cooling water leakage.
- (4) Check the lubrication oil discharge operation and direction of rotation.
 - a. Close the inlet valve of the Mechanical booster pump or put a Blind flange to the inlet port to block it.
 - b. Run the backing pump to exhaust inside the Mechanical booster pump. This time, confirm that the pressure of the inlet or outlet of the booster pump comes down around the ultimate pressure of the backing pump (13.0-1.3Pa for the standard backing pump) and keep exhausting three minutes or more only by the backing pump under that state. Exhausting three minutes shall delete the air component in the lubrication oil in the Mechanical booster pump.
 - c. Flow the Cooling water, and run the Pump around three seconds on keeping watching the Oil level gauge to check the rotation direction. Gear rotation shown in the Fig. is correct. Refer to the pump's nameplate, too. If it rotated reverse, check the motor wire connection. The Motor is a three-phase induction motor that would rotate reverse if two of three input wires were connected reverse.
 - d. After checked the direction of rotation, run the Mechanical booster pump three minutes or more to conduct the lubrication deaeration and lubrication circulation inside the Pump unit.

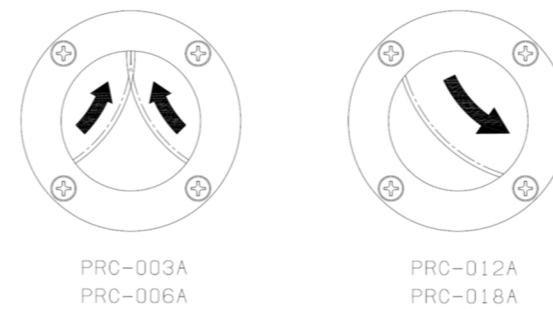

Gear rotation direction

9-2. Run

- (1) Flow the Cooling water.
- (2) Close the main valve of the Mechanical booster pump and start running the backing pump to exhaust inside pipes.
- (3) Open the main valve above the suction side of the mechanical booster pump, and exhaust inside the vacuum chamber.
- (4) Start the operation upon the vacuum chamber was exhausted to the pressure lower than the maximum inlet pressure of the Mechanical booster pump.

9-3. Operation Stop

- (1) Close the main valve (inlet side) of the Mechanical booster pump and stop it.
- (2) The Mechanical booster pump shall keep running a while by the Rotor inertia. Check and ensure that the rotation stopped through the gear (or the motor) to stop the backing pump.
- (3) Open the Suction leak valve upon stopped the backing pump to make atmospheric pressure inside the Mechanical booster pump and backing pump.
- (4) Wait until the Pump cools down as far as you can touch by hand to stop flowing the Cooling water.



ULVAC SHOWCASE