

Nitrogen Generator Instruction Manual

GN-30i

Export Control Policy

When applying our refrigerator to a cryocooler for optical sensors, the cryocooler falls under row 6.A.2.d.2 of the control list established by The Wassenaar Arrangement, which is equal to row 10(2) of appended table 1 of Japan's Export Trade Control Order.

Customers must follow all related rules and regulations such as Foreign Exchange and Foreign Trade Act and take appropriate procedures when exporting or re-exporting our refrigerators.

Introduction

Thank you for choosing our product. This instruction manual provides information and precautions on handling, installation, operation, and maintenance of the product.

This product is intended for use by qualified personnel who recognize shock hazards and are familiar with the safety precautions required to avoid possible injury. To ensure proper use of this product, read this instruction manual carefully and keep this manual close at hand so that you can use for reference during operation.

If you purchased our other products and/or optional devices with this product, read relevant instruction manuals carefully.

Safety Conventions

Our products have been designed to provide extremely safe and reliable operation when properly used. Following safety precautions must be observed during normal operation and when servicing them.



WARNING

A warning describes safety hazards or unsafe practices which could result in severe injury or loss of life.



CAUTION

A caution describes safety hazards or unsafe practices which could result in personal injury or equipment damage.



Toxic gas or chemicals used.

There is a risk of severe injury upon contact.



Corrosive chemicals used.

There is a risk of severe injury upon contact.



Flammable gas used.

There is a danger of fire or burn injury.



Explosive gas used.

There is a risk of fire or explosion.



Hazardous voltage .

Electric shock may cause severe injury or loss of life.



Hot heating part present.

There is a risk of burn injury.



Low-temperature area present.

There is a risk of frostbite. Do not touch.

Table of Contents

Safety Instructions.....	1
1. GN-30i Overview.....	5
1.1 General.....	5
1.2 Features.....	5
1.3 Specifications.....	6
2. Unpacking and Installation.....	7
2.1 Unpacking and inspection.....	7
2.2 Cautions for Installation.....	7
2.3 Electric Wiring.....	7
3. Component Descriptions.....	9
3.1 External Dimensions and Component Description.....	9
3.2 Component Details.....	10
4. System Diagram.....	12
5. Operation.....	13
5.1 Preparation before Operation.....	13
5.2 Start-up and Stop (Local operation).....	13
5.3 Start-up and Stop (Remote: Operation by input external signals).....	13
6. Operating Precautions.....	14
6.1 Operating Precautions.....	14
7. Troubleshooting.....	15
8. Maintenance.....	17
8.1 Daily Inspections and Maintenance.....	17
8.2 Total Inspection.....	17
9. Warranty.....	18

This page intentionally left blank.

Safety Instructions

Following precautions contain information regarding the safety of handling this system. Read them carefully to learn the ways of safe use.

1. Install the nitrogen generator in a safe place.



It may result in explosion or fire if there is explosive, flammable gas organic solvent close to the equipment. Place the equipment in a place free from flammable objects.

2. Do not place outdoors.



The nitrogen generator is not waterproof. If water invades into the electrical system, it may result in electric shock or fire. This system must be installed indoors.

3. Disconnect power supply before conducting inspections or servicing.



Make sure that the main power supply is turned off before starting inspections or wiring. Failure to follow this procedure could cause electric shock or severe injury.

4. Electric wiring must be done by qualified personnel.



Only qualified personnel can conduct electric wiring. If this caution is not observed, it may result in electric shock or fire.

5. Connect the ground wire.



Make sure to ground the equipment. Failure to follow this procedure could cause electric shock or fire.

6. Do not attempt to compress gas other than air.



Never attempt to compress gases other than the air. Otherwise, it may result in explosion, fire or damage to the equipment.

7. Do not inhale nitrogen gas.

Inhaling nitrogen gas may bring serious damage to human bodies.

8. Do not use the nitrogen generator in a closed room.

Do not use the nitrogen generator in a place where closed or without insufficient ventilation as it may severely damage human bodies. Use the equipment in a place where sufficient air flow is available.

9. Do not touch the compressor while turned ON.

Do not touch the compressor while it is supplied power. It may result in burn injury.

10. Release the tank pressure before inspection or maintenance.

Follow the maintenance standard for inspections and maintenance. Make sure to release tank pressure and confirm that there is no pressure before starting such works. If pressure remains, it may blow off parts, resulting in body injury.

11. Use the device at the specified temperature range.

Operate the nitrogen generator in a place where the temperature is from 5 to 40°C. The drain freezes when the ambient temperature is below 5°C, resulting in equipment failure. When it is above 40°C, it could cause equipment failure or shorten the life.

12. Install the nitrogen generator in a clean place

Installation site should be free from dirt or dust as they may cause equipment failure.

13. Repair work should be done by appropriate service providers.

It may result in failure or deterioration of life if the repair work is done by personnel who do not have adequate knowledge on the structure or risk.

14. Use our genuine parts.

When replacing parts for maintenance, our genuine parts should be used. Parts that are not genuine could cause equipment failure or shorten the life.

15. Do not remodel.

Never attempt to remodel the equipment as it may result in breakage or decrease of life.

This page intentionally left blank.

1. GN-30i Overview

1.1 General

The GN-10i generates high density nitrogen gas with PSA(*) technology. The system consists of a compressor, adsorption tank, buffer tank, pressure regulator, flow rate meter, flow rate control valve, solenoid valve, piping or control equipments.

(*)P.S.A. (Pressure Swing Adsorption)

P.S.A. is the technology to generate high density nitrogen by pressurizing or depressurizing (expose to the atmosphere from pressurized state) compressed air using the properties of adsorber (carbon molecular sieve) to adsorb and desorb oxygen.

1.2 Features

- Easy to conduct maintenance work as the panels on top or both sides can be removed.
- Automatically switched between 50Hz and 60Hz.
- Operation starts simply by pressing Run/Stop button. Once started up, GN-30i generates nitrogen gas automatically.
- To stop operation, simply press Run/Stop button.
- The compressor is long-life and low-noise type.
- Safety circuit is built inside to detect the compressor trouble. GN-30i stops automatically when a trouble occurs in the compressor.
- Drained water is evaporated by electric heater and PSA exhaust desorbed gas. There is no need of piping for drained water.

1.3 Specifications

Table 1-1 Shows the specifications of GN-30i.

Table 1-1 GN-30i Specifications

Items	Specifications	
Model	GN-30i	
Purity (*1)	99 vol%	
N2 production rate (*2)	30 NL/min	
Discharge pressure	0.2 MPa	
Dewpoint	Below -60°C	
Flow meter (*3)	50.0 NL/min	
Electrical rating Voltage and frequency	Main power source 200VAC (single-phase) 50/60Hz	
Power consumption	1200W	
Operating method	Input operation signals	
Input and output electrical signals	Input	Remote signal: CLOSE while in operation Contact capacity:DC30V 20mA required
	Output	Running signal: In operation (ON) N2 supply signal: While supplying (ON) Alarm signal: While in alarm state (ON) Relay contact output: Continuous load current 100VAC below 1A
Drained water processing	Evaporation inside the equipment	
Nitrogen gas exit	φ 6 easy coupling	
Ambient temperature(*4)	5 - 40°C	
Ambient humidity(*4)	10 - 80%RH	
Dimensions	600(W) x 650(D) x 1,300(H) (excluding casters)	
Weight	Approx. 120Kg	
Color	DIC 546 1/2	
Compressor	2688CS32-273 (made by Thomas) x 3	
Noise level	60dB(A) When measured from front 1m and height 1m	

*1 Purity of N₂(nitrogen) + Ar(argon).

*2 This is the volume measured at the ambient conditions of temperature 20°C and humidity 60% RH and converted to 0°C and atmospheric pressure. The production volume above is the maximum generation rate under the conditions of temperature 20°C and humidity 60% RH and filters are cleared. The production rate decreases when depending on the conditions such as temperature or humidity.

*3 Flow meter is made to fit the above discharge pressure. If it is used at the pressure other than the above, conversion is needed.

*4 This is not to guarantee the performance under these conditions.

2. Unpacking and Installation

2.1 Unpacking and inspection

Unpack the Carton and confirm that the carton contains the following items;

- 1) GN-30i
- 2) Instruction Manual (This book)

2.2 Cautions for Installation

Follow the precautions below when installing GN-30i.

- 1) This equipment is intended to be used indoors. Install it indoors where the temperature is from 5 to 40°C.
(The compressor life will be deteriorated if the ambient temperature is above 30°C. If the equipment is used in low temperature, it might not function well.)
- 2) The installation site must be free from waterdrops or high humidity.
- 3) Install the equipment away from direct sunlight.
- 4) Do not install in a dusty place.
- 5) Keep sufficient space in front of the air inlet or exhaust port.
- 6) Do not install the equipment in a place where closed or with inadequate ventilation.

2.3 Electric Wiring

<Input>

- Power source

Supply 200VAC, 15A outlet dedicated to the equipment.

- When the equipment is operated by external signals

Remove the plate on the left, and make short-circuit connection between 1 and 2 of the terminal board (TB2) located on the lower left of the control panel with a jumper connector. (The Run/Stop button on the operation panel will be invalid when the 1 and 2 are short circuited.) Then, short-circuit 3 and 4 on the terminal board (TB2) to start up the equipment by external signal.

<Output>

- Operation signal output 5,6 [RUN1, RUN2]
Output from when the operation starts.

- Failure signal output 7,8 [AL1, AL2]
Output when the compressor is overloaded or motor wire is disconnected.
The signal is also output when the pressure of the tank is below the set value.
(The equipment will be brought to an emergency stop. Default set at 0.2MPa)

- Nitrogen supply signal output 9,10 [RUN3, RUN4]
Nitrogen is discharged in about six minutes after the startup.
The nitrogen supply signal is output along with the discharge.

3. Component Descriptions

3.1 External Dimensions and Component Description

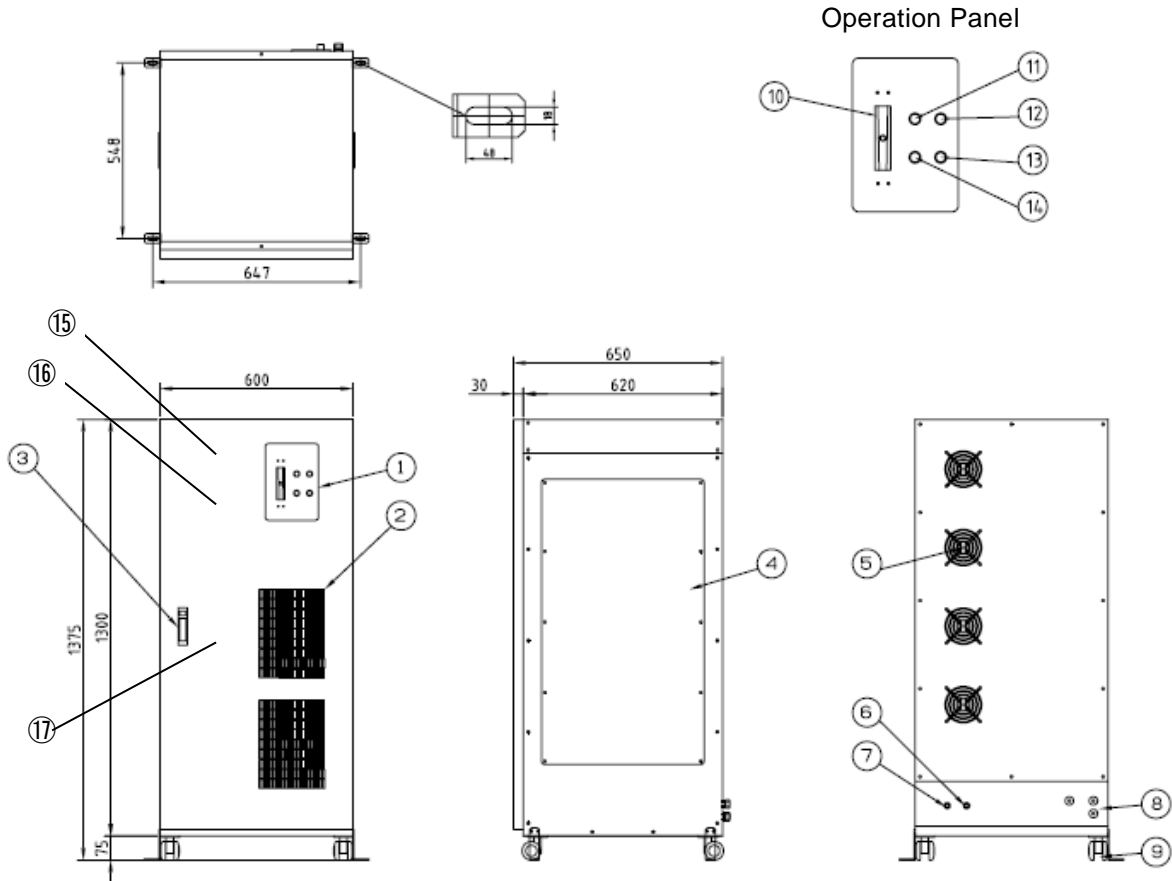

Clear the spaces below for maintenance works.

Front: 600mm or more

Sides: 600mm or more

Back: 200mm or more

①	Operation panel	⑩	Nitrogen gas flow meter
②	Air inlet	⑪	Pressure alarm light
③	Handle	⑫	Compressor alarm light
④	Maintenance port	⑬	Run/Stop button
⑤	Ventilation fan	⑭	Reset button
⑥	Spare entrance port	⑮	Pressure regulator (inside)
⑦	Nitrogen gas discharge port	⑯	Pressure sensor (inside)
⑧	Cable entrance	⑰	Circuit breaker (inside)
⑨	Casters		

3.2 Component Details

① Operation panel

② Air inlet

Port to intake the atmosphere.

③ Handle

④ Maintenance port

Make sure to turn off the power supply before opening the port. Use cautions to conduct maintenance works.

⑤ Ventilation fan

Do not block the air exit by placing the fan too close to walls or in other ways.
Take space of more than 200mm from walls.

⑥ Spare entrance port

⑦ Nitrogen gas discharge port (Rc1/4)

Exit port of nitrogen gas (produced gas)

⑧ Cable entrances

Holes for power cables.

⑨ Casters

Casters to move the equipment.

⑩ Nitrogen gas flow meter

Displays the flow rate of nitrogen gas

⑪ Pressure alarm light

Illuminates when the pressure of nitrogen tank is below the set value.
(Set value : 0.2MPa)

⑫ Compressor alarm light

[Conditions that alarm light illuminates]

- (1) When overcurrent by compressor overload is detected
- (2) When compressor wiring is interrupted

⑬ Run/Stop button and light

Press this button to startup or stop the equipment. The button illuminates while running.

The light flashes when the compressor has been running for 8000 hours (Inspection interval).

⑭ Reset button

Resets equipments when the compressor trouble or abnormal pressure occur.

⑮ Pressure regulator (inside)

Adjusts the discharge pressure of produced gas. Set the value within specified range referring to the nitrogen discharge pressure gauge.

⑯ Pressure sensor (inside)

Detects the tank pressure. This sensor triggers equipment emergency stop when the pressure is below the setting while nitrogen is being discharged.

⑰ Circuit breaker

Circuit breaker for the entire equipment.

4. System Diagram

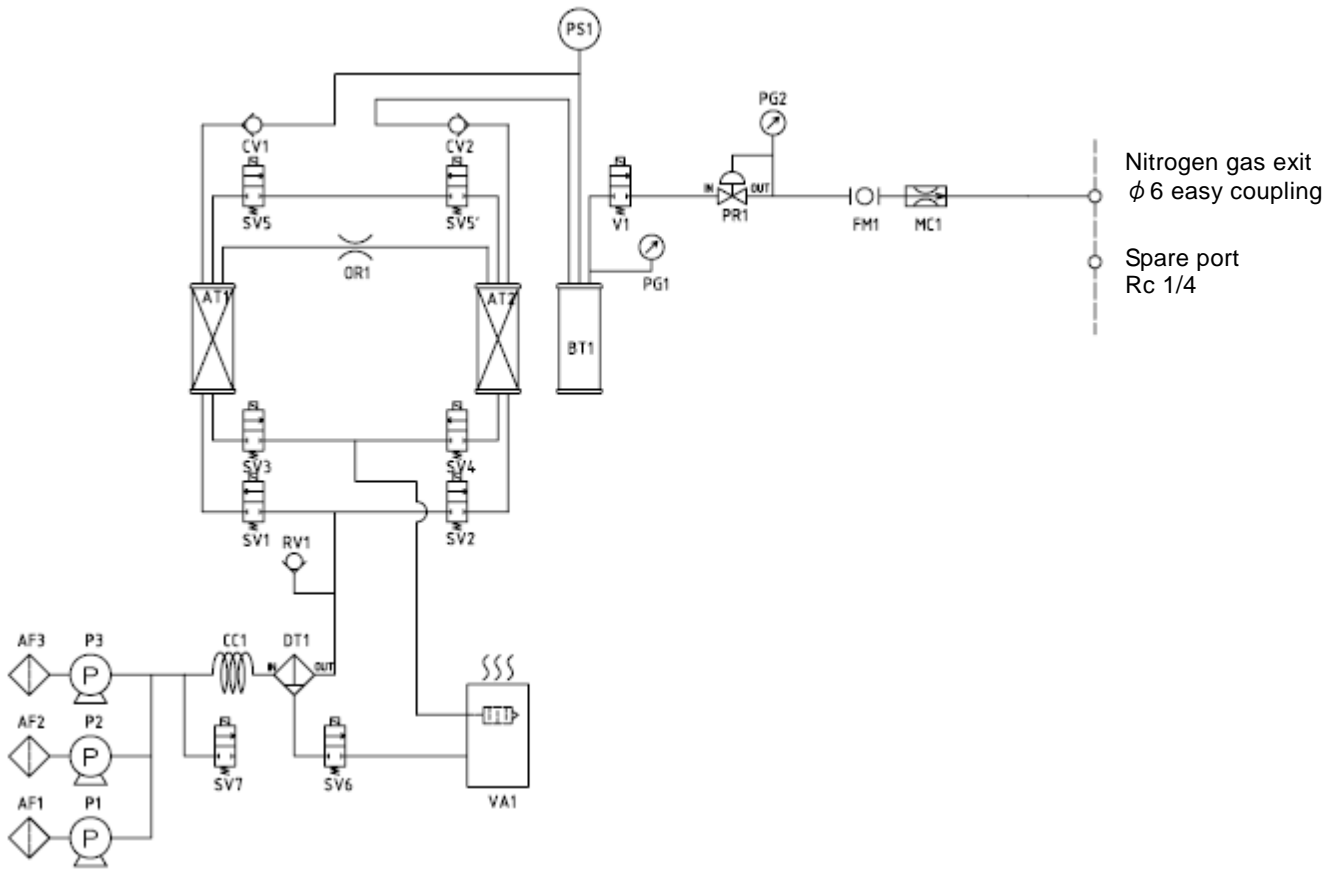

Symbol	Item	Symbol	Item
AF1-3	Intake air filter	PS1	Pressure sensor
DT1	Drain trap	RV1	Relief valve
AT1,2	Adsorption tank	MC1	Miniature valve
BT1	Buffer tank	NV1	Flow rate control valve
CC1	Cooling tube	SV1,2	Solenoid valve
CV1,2	Check valve	SV3,4	Solenoid valve
FM1	Nitrogen gas flow meter	SV5,5'	Solenoid valve
MC1	Miniature valve	SV6	Solenoid valve
OR1	Orifice	SV7	Solenoid valve
P1-3	Compressor	V1	Solenoid valve
PG1,2	Pressure gauge	VA1	Sound absorbing evaporator
PR1	Pressure regulator		

5. Operation

5.1 Preparation before Operation

- 1) Take the right side plate off, and remove the red screws (two per compressor unit) that fix the compressor unit for transportation.
- 2) Connect the piping to the nitrogen gas discharge port (Rc1/4) on the back of the equipment.
- 3) Wire the power cable, open the front door of the equipment and turn the circuit breaker on.
- 4) Remove the jumper cable connectors inside the equipment, and press Run/Stop button.
- 5) Open the door to check that the pressure meter of the pressure regulator (located behind the operation panel) is set at specification value, and check the nitrogen gas flow meter on the operation panel to confirm that the flow rate is appropriate.

5.2 Start-up and Stop (Local operation)

- 1) Press Run/Stop button on the operation panel to start-up.
Press Run/Stop button again to stop.
<Note> The system will start with the conditions set at previous time.

5.3 Start-up and Stop (Remote: Operation by input external signals)

- 1) Remove the plate on the left side to connect jumper connector connected to 1 and 2 of the terminal board (TB2).
- 2) Short-circuit 3 and 4
(Refer to "2.3. Electrical Wiring")
- 3) The system will be in operation when "making" (turned ON), and stops when "in break". (turned OFF).

6. Operating Precautions

6.1 Operating Precautions

1) Power capacity

At the time of start-up, large volume of electric current flows for a short while. If the capacity of power source is small, the operation might not proceed normally, such as the alarm light illuminates and the system stops while starting-up, or the circuit breaker inside is turned off. In such cases, use the power source with sufficient capacity as the dedicated source for the equipment.

2) When opening the side panels

When you remove the side panels to conduct the inspection of the equipment, make sure that the equipment is turned off before working.

If it is necessary to take the side panels off while in operation, use cautions never to place hands or bodies close to the compressor or cooling fans.

3) Devices inside

Never attempt to make alternations or remove the pipings, couplings or electric circuit as it may result in failure.

4) Power outage during operation

In case the power outage takes place while the equipment is in operation, the equipment may stop and the supply of produced gas stops as well. After the power recovers, the equipment will restart the operation automatically. However, if pressure remain inside the adsorption chamber, the compressor does not rotate due to the pressure under load, the safety circuit work and the operation stops along with the attention light turned on.

In such a case, press the illuminating attention light to clear. The safety circuit is canceled and the equipment will start operation again.

7. Troubleshooting

Corrective actions when troubles occur are described below.

1) Circuit breaker works

If the circuit breaker works and the equipment stops although you turn ON the breaker once again, the possible cause may be the failure of electrical system or abnormal current. Disconnect the power supply and contact us.

2) Nitrogen gas is not discharged

The possible causes are as described below.

- Not sufficient time has passed since the start-up of the equipment.
- The pressure regulator inside the equipment is closed.
- The flow rate control valve on the front of the equipment is closed.
- The piping outside the equipment is clogged.
- The pressure outside the equipment is larger than the discharge pressure.

If the produced gas is not discharged even after clearing the above problems, the possible causes may be the piping inside is disconnected, clogs of the couplings, or leaks. Please contact us.

3) Alarm light illuminates

When an alarm light illuminates and the equipment stops during operation, press Run/Stop button to clear the operating status, and then press attention light. The light is turned off and reset. Restart the equipment later. If the attention light illuminates and the equipment stops in a few seconds, the electric capacitance of the power source may not be sufficient.

Use the power outlet with sufficient capacitance and restart the equipment. If the equipment stops along with the attention light again, the cause might be the equipment failure. Turn OFF the circuit breaker, unplug the power supply and contact us.

4) The operation light flashes

When the equipment has been running for 8000 hours, the operation light flashes during operation to inform that the inspection will be necessary soon.

Press Maintenance Finish button on the left of inside the equipment for around 5 seconds to reset.

The replacement interval of the compressor is about one year (8,000 hours) if it has been running continuously. It is also necessary to check the deterioration of adsorber, piping, couplings, or solenoid valves along with the replacement. Please contact us.

5) When abnormal sound is heard

If there is a sound different from the normal operating sound, the equipment may have trouble or failure. Unplug the power cable and contact us.

6) The discharge pressure or flow rate is not in the range of specifications.

Adjust the pressure with the pressure regulator if the discharge pressure of nitrogen gas is not within the range of specifications.

If the flow rate of supplied nitrogen gas is different from the necessary rate when nitrogen discharge pressure is within the range of specifications, adjust the flow rate at the flow rate adjustment valve on the front panel of the equipment. If the discharge pressure or flow rate does not return as intended, the possible cause may be the equipment failure. Shut down operation, turn OFF the circuit breaker, unplug the power supply and contact us.

Please contact us if there are other signs of failure than stated above.

8. Maintenance

Maintenance and inspections are very important in order to keep good performance for a long time.

It is strongly recommended that the customers conduct daily inspections and maintenance. When you conduct overall inspection, it is necessary to replace consumables such as compressor. Please contact us.

8.1 Daily Inspections and Maintenance

1) Abnormal sound and vibration

Every time the equipment is used, check if it has noise large and different from usual, or large vibrations. If abnormal sound or vibration is observed, shut down the equipment immediately

2) Cleaning and replacing intake air filter

It is extremely important to clean the intake air filter attached to the compressor. The compressor performance will be deteriorated if this filter is clogged. Frequent cleaning is encouraged especially in places where dust is observed. When the clog cannot be removed by cleaning, replace the filter. Please contact us for the necessary parts.

3) Others

When cleaning intake air filter, inspect with your eyes whether couplings, piping, bolts, nuts or screws are firm enough. Tighten when they are loose.

8.2 Total Inspection

The life of the compressor is one year if it runs continuously. It is necessary to replace compressor, and inspect the adsorber deterioration, piping, couplings, or solenoid valves. If the equipment has not been running for a long time, contact us for the total inspection once a year. If the running time is short, we conduct only performance check for the compressor.

9. Warranty

1. Gratis warranty period and Warranty coverage

Gratis warranty period

Gratis warranty period is one year starting from the date of delivery.

Coverage

(1) Failure diagnosis

As a general rule, diagnosis of failure should be done on site by customer.

However, ULVAC CRYOGENICS or our service network can perform this service for an agreed fee upon the customer's request. There will be no charge if the cause of the breakdown is found to be a fault of ULVAC CRYOGENICS.

(2) Damage during transportation

When damage by delivery/transportation is admitted, the product will be repaired free of charge within the range of the guarantee expressed in the sales contract.

(3) Breakdown repairs

There will be a charge for breakdown repairs, replacements and on-site visits for the following seven conditions. In those cases the cost shall be your own expense even though the product is within the warranty period.

- (i) Breakdowns due to improper storage or handling, careless accident, software or hardware design by the customer.
- (ii) Breakdowns due to modifications of the product without consent of the manufacturer.
- (iii) Breakdowns due to maintenance of the product without authentic parts or breakdowns resulting from using the product outside the specified specifications of the product.
- (iv) Breakdowns due to contamination or corrosion caused by user's use conditions.
- (v) Breakdowns due to natural disasters (such as fire, earthquake, flood, lightning, salt damage, and so on) , environmental pollution, irregular voltage, and /or usage of undesignated power source.
- (vi) Breakdowns that are outside the terms of warranty.

(vii) Consumables and/or replacement service.

Since the above services are limited to within Japan, diagnosis of failures, etc are not performed abroad. If you desire the after service abroad, please contact ULVAC CRYOGENICS and consult us for details in advance.

2. Exclusion of opportunity loss from warranty liability

Regardless of the gratis warranty term, compensation to opportunity losses incurred to your company or your customers by failures of ULVAC CRYOGENICS products and compensation for damages to products other than ULVAC CRYOGENICS products and other services are not covered under warranty.

3. Repair period after production is discontinued

ULVAC CRYOGENICS shall accept product repairs for seven years after production of the product is discontinued.

[Manufacturer] ULVAC CRYOGENICS INCORPORATED

For technical inquiries about operation, fault diagnosis, etc.

Cryogenic Equipment Division

140-1 Megawa, Makishima-cho, Uji, Kyoto 611-0041, JAPAN

Tel: +81-774-28-5595, Fax: +81-774-20-2201

For ordering maintenance parts or requesting for quotations;

Sales Representatives in Kyoto

140-1 Megawa, Makishima-cho, Uji, Kyoto 611-0041, JAPAN

Tel: +81-774-28-5595, Fax: +81-774-20-2201

Sales division in main office

1222-1 Yabata, Chigasaki, Kanagawa, 253-0085, JAPAN

Tel: +81-467-85-0303, Fax: +81-467-85-9356

This page intentionally left blank.

SERVICE NETWORK

- For technical support, servicing or additional contact information, visit us at www.ulvac-cryo.com.

ULVAC CRYOGENICS INC.

www.ulvac-cryo.com

1222-1 Yabata, Chigasaki, Kanagawa 253-0085, Japan

<Sales>

Tel: +81-467-85-8884

<Service Engineering Division>

Tel: +81-467-85-9366

Fax: +81-467-83-4838

ULVAC CRYOGENICS KOREA INC.

www.ulvac-cryo.co.kr

107, Hyeongoksandan-ro, Cheongbuk-Myeon, Pyeongtaek-si,
Gyeonggi-Do, Korea, 17812

Tel: +82-31-683-2926

Fax: +82-31-683-2956

ULVAC CRYOGENICS (NINGBO) INC.

www.ulvac-cryo.com

No.888 Tonghui Road, Jiangbei District, Ningbo, China, 315020

Tel: +86-574-879-03322

Fax: +86-574-879-10707

This page intentionally left blank.

Revision History

Date	Revision No.	Contents
2016 / 06 / 23	2016.06	First edition

This page intentionally left blank.