



INSTRUCTION MANUAL OIL SEALED ROTARY VACUUM PUMP

VD151

VD201

Before using this product, be sure to read this operation manual.

Keep this manual with care to use at any time.

ULVAC, Inc.

Components Division

<http://www.ulvac.co.jp>

0. Before Using This Product

We thank you very much for purchasing our product.

You are kindly requested, upon delivery of the product, to check that the delivered product is exactly what you have ordered and it has no damage caused by transport or the like.

This manual gives description on operation and maintenance procedure appropriate to use the product in safe and effective way. Please read this manual beforehand to correctly use the Pump.

You are requested to install and operate the product in compliance with the laws and regulations relating to the safety, e.g. Fire Defense Law, Electric wiring regulation and so on in the country and region you use the product. Consequently you shall be requested to attend general safety lectures officially effective in the area, such as electrical safety, Cargo handling safety and so on. Note that any person not attended such lectures shall be restricted from handling the product. Operators shall need to attend such kind of training and have special knowledge, skill and title regarding the electricity, machinery, cargo, vacuum and so on.

This product is designed to conform to regulations valid at the time of issue of this manual and its conformity is not ensured if any of regulations shall be changed in the future.

The performance and safety of the product might not be ensured if any of the devices put together did not conform to same regulations or the product itself was modified. ULVAC shall be not liable to guarantee performance and safety in such cases above. Any modification of the product by the user is out of the scope of guarantee by us and not be guaranteed in any manner.

Be sure to clear any energy sources, e.g. electricity, coolant and so on of the product before installing or removing the product.

Please note that any of the parts used in this product shall keep the performance at the time of the shipment but shall not survive eternally. Any of the parts cannot, under any application supposed under socially-accepted idea, help but inevitably deteriorate its performance and get easily result in causing trouble of the product. You are kindly requested consequently to take your application situation into consideration and help yourself to implement the protective maintenance so as to avoid troubles.

Through implementation of the protective maintenance, you shall reduce occurrence of the trouble due to wear and/or failure of the part and bring reducing the occurrence of the downtime caused by the product trouble and fire as well as a risk of affecting the another process.

We would like to ask u again to establish the protective maintenance plan as well as conduct the part replacement and overhaul in accordance with such a plan.

Please do not hesitate to contact our sales office or agency closest to you or the Components Division if you had any question or unclear on the use.



CAUTION

Any part of this Instruction Manual shall be in no manner reproduced for the third party without our approval.

0.1 Safety Symbol Marks

We display symbol marks regarding the safety in this manual and on the product to make clear items to observe. Descriptions attached to the symbol are classified as illustrated below;

0.2 Meanings of Safety Symbol Marks



DANGER

If the user makes a mistake in handling, it indicates an imminent possibility that the user is subject to death or heavy injury.



WARNING

If the user makes a mistake in handling, it indicates a possibility that the user is subject to death or heavy injury.



CAUTION

If the user makes a mistake in handling, it indicates a possibility that the user is subject to moderate injury or it leads to significant damage of the machine. It indicates a possibility that damage of the machine is caused and the normal operation is impaired.

IMPORTANT

[IMPORTANT] description shall be given where there is particular information to notice for the operation or maintenance work of the product.



Training for the electrical safety is required as there is a risk of electrical shock.



Check and ensure that the pump is sufficiently cooled down as this section keeps high temperature after having stopped the pump.

0.3 Safety Precautions

Descriptions are given as the method to keep away from danger and actions that must be restricted on the use of the product.

Use of this product and this Instruction Manual.



DANGER

Please read this Instruction Manual before starting installation, operation check or maintenance of this product to use it in long term. You are requested to fully understand the safety precautions, specifications and operation methods of the product.



DANGER

Use of the toxic, combustible or combustion susceptible gas other than inactive gas is not allowed as there is a risk of leakage of the gas from the Pump unit if it was exhausted by the vacuum pump.



DANGER

Use of the toxic, combustible or combustion susceptible gas and substance other than inactive gas is not allowed as there is a risk of causing fire or explosion inside the Pump unit if it was exhausted by the vacuum pump.



DANGER

Pump oil as well as the Pump unit becomes toxic should the toxic gas was sucked in the vacuum pump. Pay attention to execute maintenance work.



WARNING

We would be obliged to refrain from handling and/or executing maintenance of the product if the detail of used hazardous substance was not disclosed or the product has exhausted such substance that the detoxification process is hardly conducted.

**WARNING**

You are kindly requested to acknowledge that specifications and/or price of the product and description of the Instruction Manual are subject to change without prior notice for improvement.

Any change shall update the version number at the top right of the Instruction Manual cover and issue the revised version.

**WARNING**

This Instruction Manual shall absolutely need to be delivered to the last user that uses the product.

**WARNING**

To export this product abroad, you have to clear the examination in accordance with the Foreign Exchange law, Foreign Trade law and relevant decree, ordinance and order.

Please feel free to contact our sales office or agency closest to you or our Components Division.

Installation and storage

**WARNING**

- 1) When taking out the product from the box and lifting up the pump, guide to use the cargo-handling equipment such as a crane utilizing the eyebolt located at the upper part of the pump and to transfer lifting it up. Confirm that there is no abnormality before using the eyebolts.
- 2) Only the technically entitled person should be in charge of conducting the unloading operation and operating the unloading machinery.
- 3) There is a risk that the Pump might drop or lay down when attempted unreasonable operation or machinery setup was not sufficient. You are strictly restricted to enter beneath the Pump.
- 4) Since you may get injury due to an anchor being used in the box, guide the worker to wear the leather gloves and to use the appropriate tool.

Transfer

**WARNING****Pump Weight**

VD151 : 29kg

VD201 : 34.5kg

When you carry a pump, you have a risk of giving damage to your back.

Be sure to use the loading machinery (such as mobile crane) to lift up the Pump or load it on the pallet and fix it and run the Pallet truck for its transfer.

Countermeasure to the earthquake

**WARNING**

There is a risk that the Pump lays down or slides and breaks peripheral units if it was not correctly fixed. Be sure to give allowances to the vacuum piping and electric cables so that they absorber vibrations to prevent them from breaking and/or dismantling.

Inlet piping <Mounting>

**WARNING**

Check and ensure that any of hazardous energy is blocked before starting the operation.

Power Supply wiring <Mounting>

**WARNING**

- 1) Check and ensure that any of hazardous energy is blocked before starting the operation.
- 2) Entitled staff should conduct the wiring operation. Erroneous wiring work might cause a fire.
- 3) Conduct the wiring operation correctly in compliance with laws and rules concerning the safety (e.g. Fire Defense Law, Electric Equipment Technology standard, Internal line cord) in the country and region you use the product.
- 4) Ensure to have a correct grounding.
- 5) You are recommended further to install a dedicated Leak breaker. You have a risk of getting electrical shock in case of failure or electric leakage.
- 6) It is imperative to put the Overload protection device. Otherwise it would cause the motor burn out and/or fire.

Operation

**WARNING**

Do not run the Pump on blocking the exhaust outlet or putting any device that might hamper gas passage onto the outlet. There is a risk that the pressure inside the Vacuum pump rises up to cause break or oil leak of the casing or Oil level gauge resulting in overload of the motor.

This product is not made as the withstand pressure structure. Ensured pressure value of the Pump shall be 0.03MPaG (0.3kg/cm²G) (Gauge pressure).

**WARNING**

Do not operate the Pump in hazardous area (where there is a risk of creating hazardous atmosphere by explosive gas). It might cause injury and/or fire.

**WARNING**

- 1) Be sure to turn OFF the Power Supply to execute check and repair. You have a risk of getting electrical shock or injury by accidental sudden move.
- 2) Person other than Repair technician should not be in charge of dismantling, repairing or remodeling the product.
- 3) You have a risk of getting injured or electrical shock by a fire or erroneous move.
- 4) Do not touch the Motor, vacuum pump or piping during the pump operation and just after stopped it while the pump unit keeps high temperature. You have a risk of getting burned.
- 5) Should you found any malfunction or error, just turn OFF the Power Supply to prevent accident and ask the agency or closest Service Center for check and repair.



CAUTION

- 1) Do not attempt to put your hand or article in the opening of the motor; you have a risk of getting electrical shock, injury or causing a fire.
- 2) Do not touch any rotary section such as the motor, main spindle or spindle joint during operation of the Vacuum pump; it shall bring in injuries.
- 3) Strictly refrain from putting any combustible substance in and around 1m of the motor and Vacuum pump; there is a risk of getting a fire.
- 4) Do not put a wall or obstacle in and around 0.1m of the air outlet of the motor (Motor edge face). You have a risk of getting burned or fire caused by over heat.

Power Supply wiring <Dismantling>



WARNING

Be sure to cut off the electricity before starting install or dismantling operation.

Inlet piping <Dismantling>



WARNING

- 1) Take off the piping following the Install Manual of the system.
- 2) The Inlet piping remains very hot while after having stopped the Pump. Be sure to take it off after the Pump has sufficiently cooled down.
- 3) Make airtight completely the Pump exhaust outlet with a blank flange.

Transfer



WARNING

Pump Weight

VD151 : 29kg

VD201 : 34.5kg



When you carry a pump, you have a risk of giving damage to your back.

Be sure to use the loading machinery (such as mobile crane) to lift up the Pump or load it on the pallet and fix it and run the Pallet truck for its transfer.

0.4 Types and Descriptions of Warning Labels Displayed on This Machine and Displayed Positions

Warning labels are attached on the warning locations in this system.

Be sure to check them before starting operation of the Pump.

1		<p>There is a risk of getting electrical shock around the section that this warning label is put. Be sure to turn OFF the Power Supply to execute the wiring and/or maintenance work. Never fail to close the Terminal box cover to operate the Pump.</p>
2		<p>Do not run the Pump on blocking the Exhaust outlet or putting any device that might hamper gas passage onto the outlet. There is a risk that the pressure inside the vacuum pump rises up to cause break the casing or Oil level gauge resulting in overload of the motor.</p> <p>Following gases cannot be evacuated because these gases may cause the pump inner pressure to increase due to internal combustion.</p> <ol style="list-style-type: none"> 1) explosive gas 2) flammable gas 3) gas which increases the susceptibility of substances to burn.
3		<p>Long term storage of the Vacuum pump without operation might possibly cause trouble in operation caused by rust. If you kept the Pump long time without operating it, ask a closest Service Center for the check.</p>

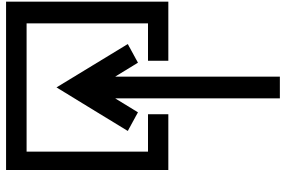
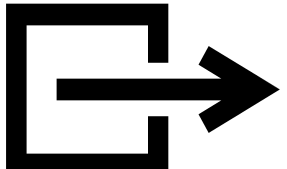
4		<p>The whole part becomes hot during operation of the Pump. Do not touch during or just after stopped operation while the Pump unit remains very hot.</p> <p>In the continuous operating (Atmospheric pressure~10KPA) which the inlet pressure is high, the surface temperature of the pump has a possibility exceeding 90°C. Provide the appropriate protection in order to avoid the contact with the surface. Use the pump assembling inside the system.</p>
5	<p>- WARNING - THIS UNIT HAS BEEN SET FOR 200-240V - 50/60Hz OPERATION BY THE END USER. SEE INSTRUCTION MANUAL.</p>	<p>The setting in the factory shipment is 200V-240V(50Hz/60Hz).When using in 380V-460V(50Hz/60Hz), switch the connection inside the terminal box by the customer.Refer to “3.5 Electrical Connection”.</p>
6	<p>CAUTION To Reduce the Risk of Electric Shock or Injury, Use Indoors Only. Mount at least 100mm from side walls.</p>	<p>To reduce the risk of Electric Shock or Injury, Use Indoors Only. Mount at least 100mm from side walls.</p>
7	<p>CAUTION To prevent back injuries, always use at least two people when lifting and moving the pump.</p>	<p>Pump Weight VD151 : 29kg VD201 : 34.5kg</p> <p>When you carry a pump, you have a risk of giving damage to your back.Be sure to use the loading machinery (such as mobile crane) to lift up the Pump or load it on the pallet and fix it and run the Pallet truck for its transfer.Or, to prevent back injuries, always use at least two people when lifting and moveing the pump.</p>
8	<p>USE ONLY IN HORIZONTAL POSITION</p>	<p>In installing, set the pump in horizontal position and place it so that there is no rattle.</p>
9		<p>INLET</p>
10		<p>OUTLET</p>

VD151

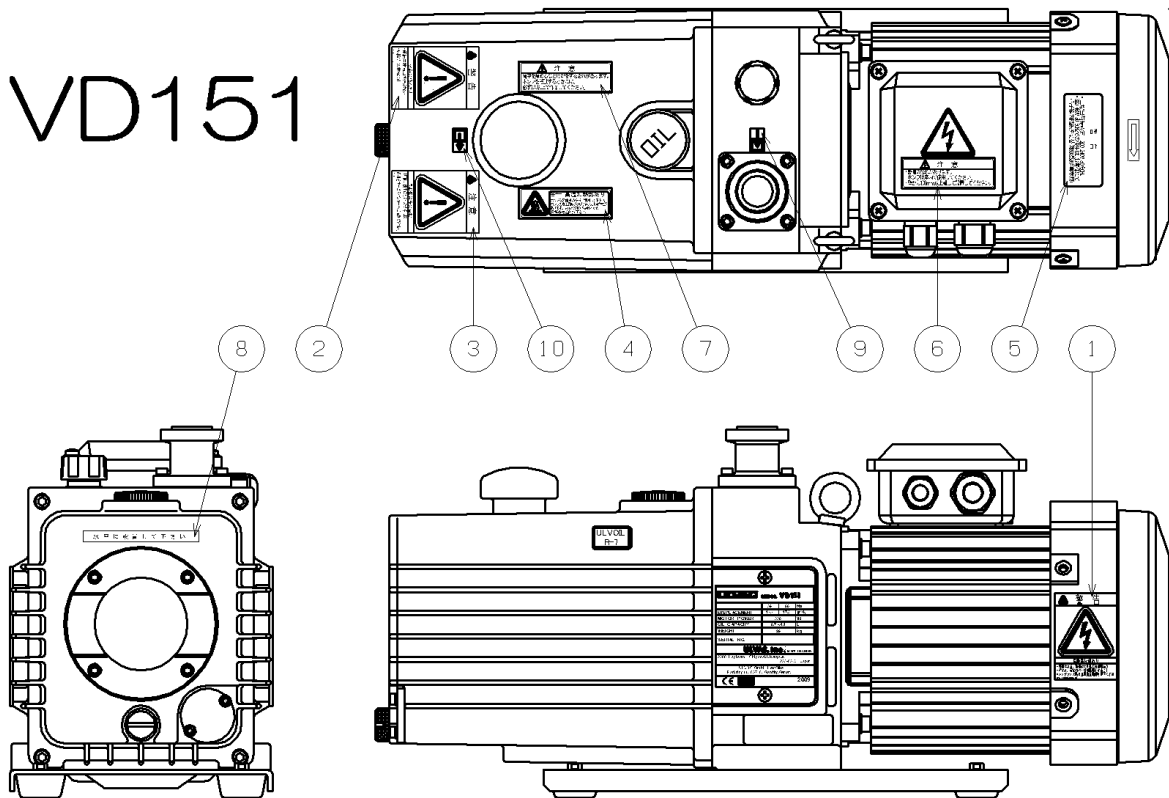

VD201

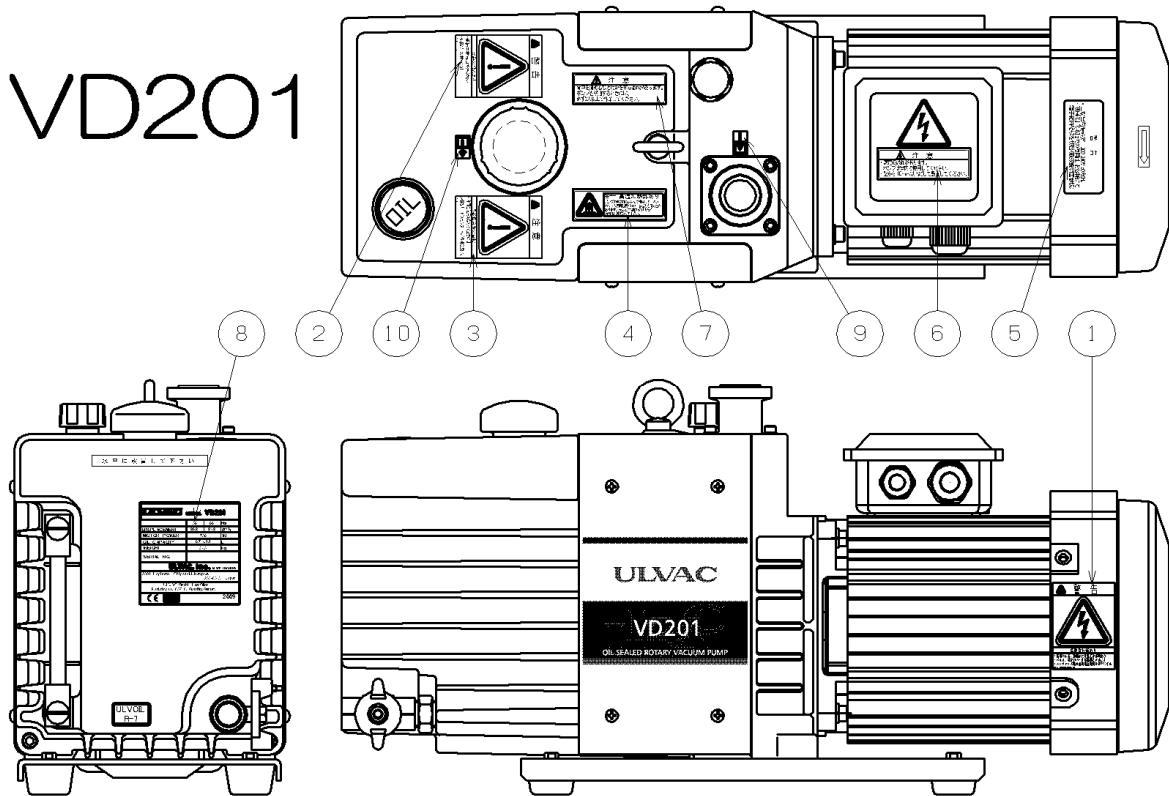

Fig. 1 Warning Label

0.5 Acceptance and Storage of The Pump

0.5.1 Unpacking/Acceptance of The Pump



WARNING

- 1) When taking out the product from the box and lifting up the pump, guide to use the cargo-handling equipment such as a crane utilizing the eyebolt located at the upper part of the pump and to transfer lifting it up. Confirm that there is no abnormality before using the eyebolts.
- 2) Only the technically entitled person should be in charge of conducting the unloading operation and operating the unloading machinery.
- 3) There is a risk that the Pump might drop or lay down when attempted unreasonable operation or machinery setup was not sufficient. You are strictly restricted to enter beneath the Pump.
- 4) Since you may get injury due to an anchor being used in the box, guide the worker to wear the leather gloves and to use the appropriate tool.

Upon delivery of the product, check first that the delivered is exactly what you have ordered and there is no break or damage through transport or the like. Claim after use of the product might be resolved with a charge.

Although we pay full attention on shipping, you are kindly requested to check the following upon unpacked the product.

IMPORTANT

- 1) Whether the delivered is exactly the one you have ordered.
- 2) Whether accessories (Pump oil for one lubrication, optional parts) are attached or not.
- 3) Whether there is no break or damage through transport or not.
- 4) Whether any bolt or nut got loose or taken off through transport or not.

Should you found any trouble, please do not hesitate to contact our Sales division or your agency.

0.5.2 Transfer**WARNING****Pump Weight**

VD151 : 29kg

VD201 : 34.5kg

When you carry a pump, you have a risk of giving damage to your back.

Be sure to use the loading machinery (such as mobile crane) to lift up the Pump or load it on the pallet and fix it and run the Pallet truck for its transfer.

0.5.3 Ambient Condition for Storage, Install and Operation

As precise clearances are provided with this machine, be sure to fulfill the following for its storage, install and operation;

- (1) Ambient temperature and humidity for storage : -10° C to 60° C, less than 95%RH
(no freeze, no condensation)
- (2) Ambient temperature and humidity for operation : 4° C to 40° C, less than 80%RH
(no condensation).However, "ULVOIL R-4" shall be used for $4-10^{\circ}$ C operation and "ULVOIL R-7" shall be used for $10-40^{\circ}$ C operation.
- (3) Height (for both storage and operation) : Lower than el. 1,000m.
- (4) External vibration (for both storage and operation) : Vibration acceleration less than 114dB (0.5G)
- (5) Miscellaneous (for both storage and operation):
 - a. There shall be no corrosion behavior or explosive gas.
 - b. There shall be no freeze or dew formation.
 - c. There shall be no dust.
 - d. It shall be in house.
 - e. Another pump shall not be put on the Pump.
The Pump shall not be laid down nor put touching its motor edge face or oil gauge edge face with the ground.
 - f. There shall be no direct sun beam.
 - g. Heat source shall be put away from the Pump.

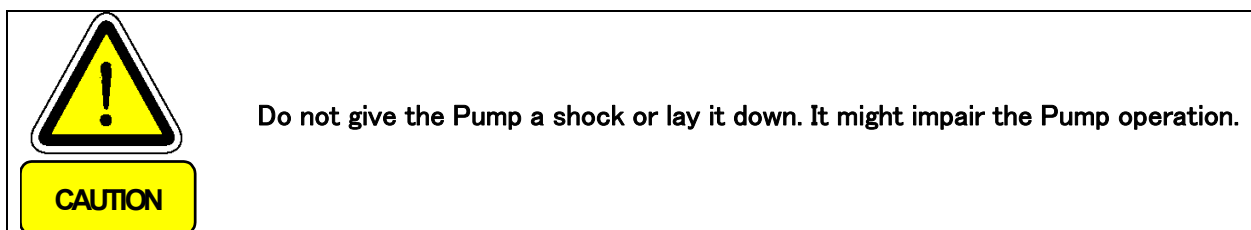

The rubber leg is attached to the base. In installing, set the pump in horizontal position, and place it so that there is no rattle.

0.6 Protective Device

The pump is equipped with a three-phase 200V~240V (50/60 Hz) / 380V~460V (50/60 Hz) motor. This motor is not equipped with the protective device. Put an overload protective device to connect through the motor with the Power Supply. It is imperative to put the overload protective device under direction of the Electrical Installation Technical Standard (1965, Department of Trade and Industry decree No. 61). Refer to “3.5 Electric connection” to select the overload protective device. It is recommended to put together another protective device such as a leakage breaker.



It is imperative to put the Overload protection device. Otherwise it would cause the motor burn out and/or fire.

Table of Contents

0. Before Using This Product.....	i
0.1 Safety Symbol Marks.....	ii
0.2 Meanings of Safety Symbol Marks	ii
0.3 Safety Precautions	iii
0.4 Types and Descriptions of Warning Labels Displayed on This Machine and Displayed Positions	ix
0.5 Acceptance and Storage of The Pump	xii
0.5.1 Unpacking/Acceptance of The Pump.....	xii
0.5.2 Transfer	xiii
0.5.3 Ambient Condition for Storage, Install and Operation	xiv
0.6 Protective Device	xv
1. For Your Safety Use.....	1
1.1 This Product Intrinsic Hazardous Nature and Safety Measures	1
1.1.1 Danger Leakage of dangerous gas and dangerous materials	1
1.1.2 Warning Transfer of heavy material	1
1.1.3 Warning Electric shock.....	2
1.1.4 Warning Explosion.....	2
1.1.5 Caution High temperature.....	2
1.2 Chemical Material Safety Data Sheet (MSDS)	3
2. Pump Outline	4
2.1 Characteristics	4
2.2 Performance Specifications	5
3. Mounting.....	8
3.1 Installation	8
3.2 Lubrication	8
3.3 Air Suction Piping.....	10
3.4 Exhaust Connection	11
3.5 Electrical Connection.....	12
4. Operation	17
4.1 Caution on Operation.....	17
4.2 Operation Start	19
4.3 Operation Stop	21
4.4 Gas Ballast Function.....	22

4.5 Vacuum Pump Oil For cold district.....	23
4.6 Oil mist trap (Optional).....	24
5. Pump Performance.....	26
5.1 Ultimate Pressure	26
5.2 Exhaust Speed.....	26
5.3 Required Motive Energy.....	28
6. Maintenance and Check.....	29
6.1 Maintenance	29
6.2 Regular Check.....	29
6.2.1 Pump Oil Level Check.....	30
6.2.2 Vacuum Pump Oil Check	30
6.2.3 Oil Leak Check.....	33
6.2.4 Checking The Gas Ballast Function	33
6.2.5 Checking The Metal Mesh at The Suction Inlet	33
6.2.6 Checking The Noise and Abnormal Vibration	33
6.2.7 Checking The Coupling and Spider	33
6.2.8 Checking The Oil Mist Trap	35
6.2.9 Checking the drain valve.....	35
6.3 Checkup after storage for a long period	36
6.4 Overhaul.....	36
6.5 Trouble check list.....	37
7. Disposal.....	43
8. Product Warranty.....	44
8.1 Warrantable Items	44
8.2 Duration of guarantee.....	44
8.3 Warrantee scope.....	44
8.4 Response procedure	44
8.5 Disclaimer	45
8.6 Others	45
9. Main Displacement Parts.....	46

Request Form for Repair/Inspection of ULVAC Components /Certificate of Contamination
SERVICE CENTER

Tables and Illustrations

Table. 1 Performance specifications.....	5
Table. 2 Electric capacity of the motor overload protector.....	13
Table. 3 Specification of the temperature sensor (PTO).....	16
Table. 4 Recommended replacement cycle of the vacuum pump oil.....	30
Table. 5 Trouble check list.....	37
Table. 6 Main displacement parts list (VD151).....	46
Table. 7 Main displacement parts list (VD201).....	47
Fig. 1 Warning Label.....	xi
Fig. 2 VD151 Dimensional drawing.....	6
Fig. 3 VD201 Dimensional drawing.....	7
Fig. 4 Lubrication and oil level indication.....	9
Fig. 5 Connection to vacuum chamber (example).....	10
Fig. 6 Terminal box internal wiring diagram.....	14
Fig. 7 Electrical wiring diagram.....	14
Fig. 8 To use Oil mist trap “Model TMX-1” for “VD151 or VD201”.....	24
Fig. 9 When having mounted oil mist trap and adapter.....	25
Fig. 10 Show the relationship between the suction pressure and pumping speed – MODEL VD151/VD201.....	27
Fig. 11 Replacement of coupling spider.....	34

1. For Your Safety Use

1.1 This Product Intrinsic Hazardous Nature and Safety Measures

Before operating or checking this machine, thoroughly read this paragraph, and after fully understanding about latent danger and on how to avoid danger, perform the work.

1.1.1 Danger Leakage of dangerous gas and dangerous materials

Factors	Avoidance methods and measures
 Leakage of poisonous and combustible gas	Do not exhaust any hazardous gas such as toxic and combustible.
Getting injured on touching any toxic pump oil, pump, generated material or sucked substance at the occasion of check or disposal.	1) When you check the pump, please wear a brace that supports the toxic substances that exhaust the pump.
	2) To overhaul or dispose, ask the special agency to do the detoxification process.
	3) Ask the disposal agency licensed by the administration for disposal.

1.1.2 Warning Transfer of heavy material

Factors	Avoidance methods and measures
 Getting injured on transferring the pump. Pump weight VD151: 29kg VD201: 34.5kg	1) Only technically entitled person should be in charge of loading/unloading and operating machines.
	2) There is a risk that the Pump might drop or lay down when attempted unreasonable operation or machinery setup was not sufficient. You are strictly restricted from entering beneath the Pump.

1.1.3 Warning Electric shock

Factors	Avoidance methods and measures
 <p>Getting electrical shock on touching the current-carrying part of the motor.</p>	1) Be sure to cut the electricity to do electrical connection. Never fail to take the grounding.
	2) Ensure to close the cover of motor terminal box and never open it during operation.
	3) Be sure to cut the electricity to do checking or installation.
	4) Never attempt to put in the hand or bar into the opening of the Motor.
Motor terminal mount gets burnt	Tighten close the terminal. Check the tightening once a month.(Refer to “3.5 Electrical connection”)

1.1.4 Warning Explosion

Factors	Avoidance methods and measures
 <p>Pressure inside the pump rises up and the pump explodes.</p>	Ensured pressure value of the Pump is 0.03MPaG (0.3kg/ cm ² G) (Gauge pressure).Check the Exhaust side pressure of the pump. If it was over 0.03 MPaG(0.3 kg/cm ² G)(Gauge pressure) take away anything in and around the exhaust outlet that hampers gas passage. If you used the Oil mist trap, replace it so that it does not hamper the gas passage.

1.1.5 Caution High temperature

Factors	Avoidance methods and measures
 <p>Getting burnt on touching the high temperature part.</p>	1) The Pump gets high temperature during operation.Apply an appropriate protection to avoid to touch the surface as necessary.
	2) As the surface temperature is high, you have a risk of getting burnt by accidentally touching it with the hand or the like. Refrain from touching the pump during operation. Wait until the temperature sufficiently cools down after having stopped the pump to conduct check or something.
	3) Do not touch the Pump unit or the Motor when operating the Gas ballast valve.

1.2 Chemical Material Safety Data Sheet (MSDS)

IMPORTANT

Chemical material used for this Pump;

- 1) ULVOIL R-7 (Standard)
- 2) ULVOIL R-4 (Cold area or winter time)

The Chemical Material Safety Data Sheet introduces the chemical material potential to use or touch on operating this machine. Please contact our Sales division if you are in need.

Read it with attention to acknowledge the toxic characteristics described on the MSDS.

Please do not use the chemical material except the above-mentioned chemical material (vacuum pump oil).



CAUTION

MSDS is posted as referential to ensure safe operation of the hazardous and/or toxic chemical material. Any person in charge of operating the Pump oil shall be requested to be responsible to cause means appropriate to actual operation of the machine referring to it. Note that the MSDS itself shall be never a safety certificate in any manner.

2. Pump Outline

2.1 Characteristics

The VD151 and VD201 are a compact, low noise, Gaede type two-stage vacuum pump that permits high speed rotation. Since the pump is small, light, and quite simply constructed, it is easily maintained and repaired.

Features of this pump include the following:

1) Employment of lubrication pump system

This provides stabilized pumping performance in continuous pumping operation under near atmospheric pressure.

2) Employment of hydraulic oil anti-sucking system

If the power fails or the pump is stopped for a long time without venting the intake side to atmospheric pressure, the pump oil- will flow back to the cylinder, making restart difficult.

This pump is equipped with the oil anti-sucking feature to minimize the amount of oil flowing back to the cylinder and to reduce the load at restart of the pump..

3) Employment of variable oil level system

This pump has a wide oil level indicating range to allow easy control of oil level. The pump is operable if the oil level is within this oil level indicating range during operation.

4) Employment of gas ballast function

This product is installed with the Gas ballast function as standard. This proves effective when pumping condensable gas, such as water content, organic solvent and the like.

2.2 Performance Specifications

Table. 1 Performance specifications

型番 Model		VD151		VD201		
RATED FREQUENCY Hz		50	60	50	60	
設計排気速度 Displacement m ³ /hour (L/min)		14.4(240)	17.3(288)	20.2(336)	24.2(403)	
到達圧力 ※1 Ultimate Pressure Pa	GV 閉 ※2 GV Close	0.67				
	GV 開 ※2 GV Open	6.7				
使用モーター ※3 Motor		全閉外扇フランジ型3相交流モーター Totally-Enclosed Fan-Cooled Flange Induction Motor				
kW (極数)		0.55 (4)		0.70 (4)		
定格電圧 RATED VOLTAGE V	50HZ	200V / 220V 230V / 240V 380V / 400V 415V	60HZ	200V / 220V 230V / 240V 380V / 400V 440V / 460V	50HZ	200V / 220V 230V / 240V 380V / 400V 415V
	60HZ	200V / 220V 230V / 240V 380V / 400V 440V / 460V	200V / 220V 230V / 240V 380V / 400V 440V / 460V	200V / 220V 230V / 240V 380V / 400V 440V / 460V	200V / 220V 230V / 240V 380V / 400V 440V / 460V	
定格電流 RATED CURRENT A	200V / 220V 230V / 240V 380V / 400V 415V	2.90 (200V) / 3.10 (220V) 3.30 (230V) / 3.60 (240V) 1.80 (380V) / 1.90 (400V) 2.00 (415V)	2.70 (200V) / 2.60 (220V) 2.70 (230V) / 2.70 (240V) 1.50 (380V) / 1.60 (400V) 1.60 (440V) / 1.70 (460V)	3.60 (200V) / 3.80 (220V) 4.00 (230V) / 4.20 (240V) 2.20 (380V) / 2.20 (400V) 2.40 (415V)	3.20 (200V) / 3.20 (220V) 3.20 (230V) / 3.30 (240V) 1.80 (380V) / 1.90 (400V) 2.00 (440V) / 2.10 (460V)	
	所要油量 ※4 Oil requirement L	MAX	1.1			
	MIN	0.7				
質量 Weight Total kg		29		34.5		
パッキング Packing		ニトリルゴム nitrile-butadiene rubber				
オイルミストトラップ Oil Mist Trap (Option)		TMX-1 (アダプタ付き) TMX-1 (and an adapter)				

- *1) The ultimate pressure is the value indicated on the Pirani gauge when the standard oil (ULVOIL R-7) is used. The ultimate pressure when the McLeod gauge is used is approx. one digit lower than the value indicated on the Pirani gauge.
- *2) GV close: When the gas ballast valve is closed
GV open: When the gas ballast is fully opened
- *3) By wire connection change in motor terminal box, this pump works at the prescribed voltage without exchanging motor.
The setting in the factory shipment is 200V-240V(50Hz/60Hz).When using in 380V-460V(50Hz/60Hz), switch the connection inside the terminal box by the customer.
- *4) The vacuum pump oil specifications such as vapor pressure and viscosity depend on the kinds of oil. If the other oil than the specified vacuum pump oil is used, the pump performance may be low.
Specified oil: ULVOIL R-7 (standard oil)
ULVOIL R-4 (cold area or winter time)
ULVOIL R-4 is unfitted for high load operation. When performing the high load operation, use ULVOIL R-7, and either warm the pump oil or perform the pump jog at several times, and the start up it.
- *5) In VD201, when the continuous operation is performed at 10,000Pa~50,000Pa, since the pump becomes high temperature, the maintenance cycle becomes shortented.

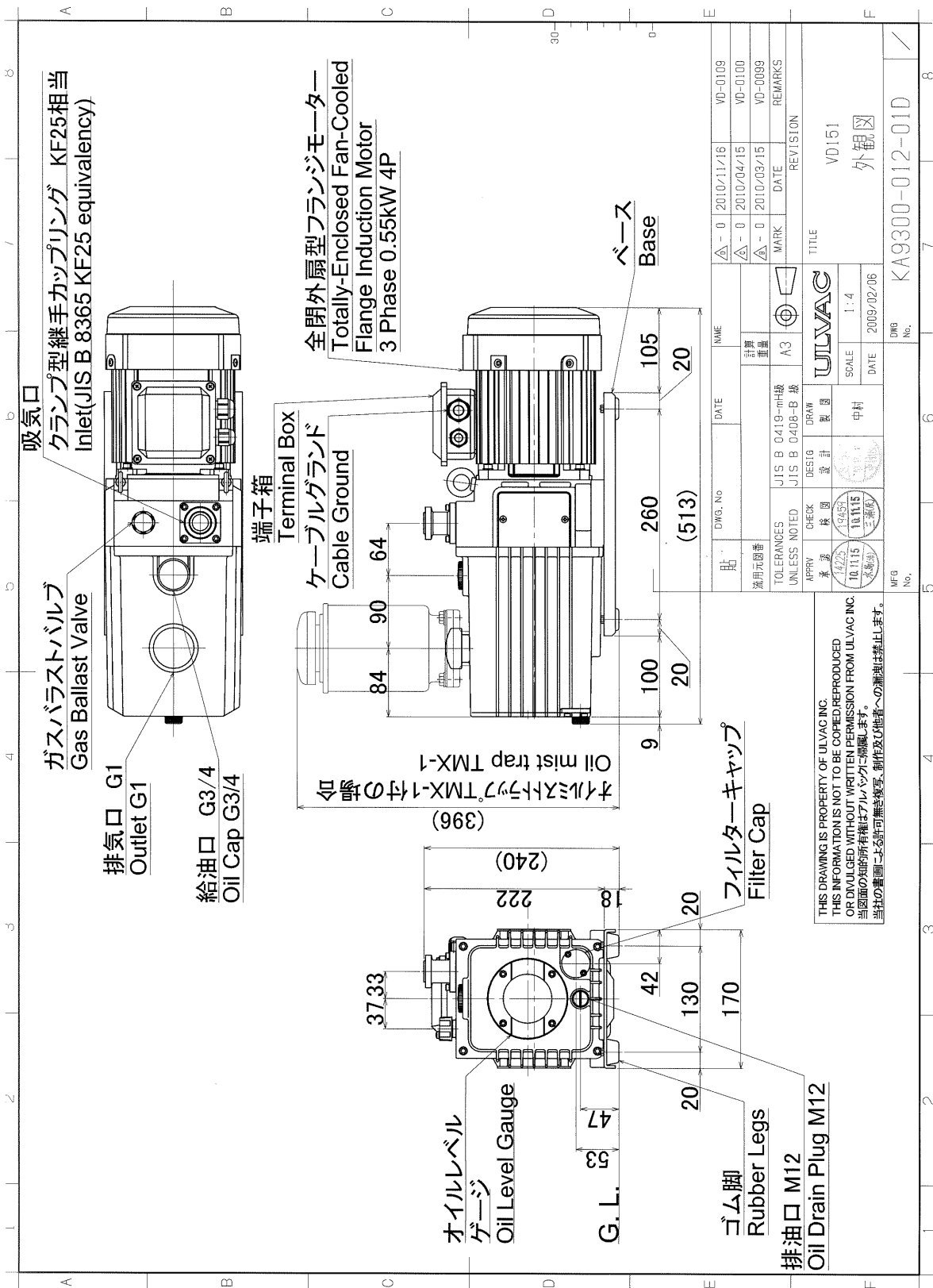

批准	DATE	NAME	規格	数量	備考
△-0	2010/11/16				VD-0109
△-0	2010/04/15				VD-0100
△-0	2010/03/15				VD-0099
MARK	DATE	REVISIONS			
APPROV	CHECK	DESIGN	DRAW	TITLE	
JIS B 0419-中級	JIS B 0408-B級	A3		VD151	
TOLERANCES UNLESS NOTED			SCALE 1:4		
DATE 2009/02/06			DATE 2009/02/06		
DWG. No. KA9300-012-01D			WFG No.		

THIS DRAWING IS PROPERTY OF UIVAC INC.
 THIS INFORMATION IS NOT TO BE COPIED, REPRODUCED
 OR DIVULGED WITHOUT WRITTEN PERMISSION FROM UIVAC INC.
 当図面の知的財産権はアルファに帰属します。
 当社の書面による許可なく複製、制作及び他者への漏洩は禁止します。

Fig. 2 VD151 Dimensional drawing

3. Mounting



WARNING

You are requested to install and operate the product in compliance with the laws and regulations relating to the safety, e.g. Fire Defense Law, Electric wiring regulation and so on in the country and region you use the product. Consequently you shall be requested to attend general safety lectures officially effective in the area, such as electrical safety, Cargo handling safety and so on. Note that any person not attended such lectures shall be restricted from handling the product. Operators shall need to attend such kind of training and have special knowledge, skill and title regarding the electricity, machinery, cargo, vacuum and so on. Be sure to clear any energy sources, e.g. electricity, coolant and so on of the product before installing or removing the product.

3.1 Installation

Install the machine horizontal to a place where there are less dust and humidity. Make a layout taking into consideration of works such as setting, removal, check, cleaning and so on.

As for the environmental condition, please refer to “0.5.3 Ambient Condition for Storage, Install and Operation”



CAUTION

Operating the pump on laying it down or putting it reverse would give damage to the pump. Ensure to install the pump horizontal to the ground level as illustrated on the Fig. 2 and Fig. 3.

3.2 Lubrication

Remove the oil filling plug and fill the pump with oil until the oil level comes between the two level lines of the oil level gauge (Refer to the “Fig. 4 Lubrication and oil level indication”).

The pump is operable if the oil level is between the two level lines of the oil level gauge during operation.



CAUTION

1) The oil level comes down approximately 1cm when operated the Pump.

Do not start the pump with the minimum level oil.

2) Do not operate the pump without adding pump oil. If it is operated in an oil-less condition, the pump will be damaged.

1) Wear protective gears such as rubber gloves, protective goggles and so on.



2) Read “1. 2 Chemical Material Safety Data Sheet” previously before starting lubrication.

Should the oil touched to your hand are entered in your eye, immediately follow the emergency treatment described on the MSDS.



Ensure to use the vacuum pump oil designated by ULVAC. Operation using oil other than designated shall be out of our scope of guarantee as it might impair the pump performance and shorten the life cycle.

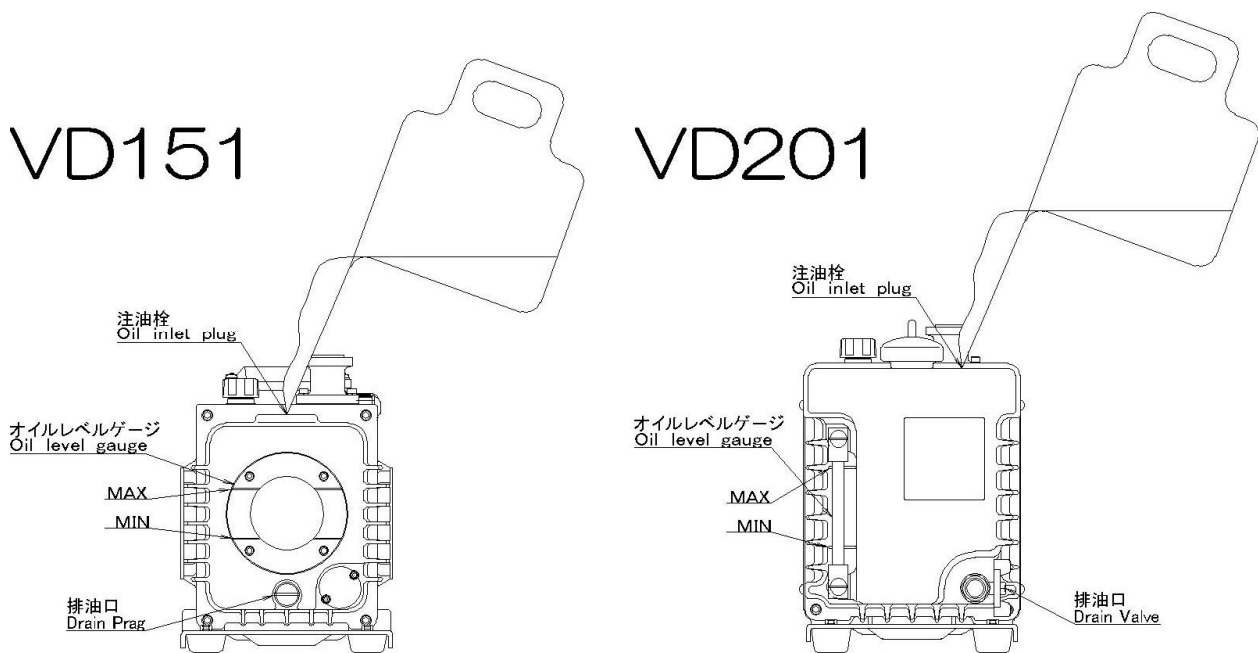

Fig. 4 Lubrication and oil level indication

3.3 Air Suction Piping

1) Before connecting the piping to the pump, clean the vacuum chamber, piping, vacuum valve, etc. well. If they are contaminated, the ultimate pressure may be higher or a longer time may be required to reduce pressure to the specified level. Wear a pair of gloves to touch any vacuum section. Do not touch with the bare hand.

2) Use the KF25 (JIS B 8365 –Dimensions of Clamped – type Vacuum Couplings–)for connection between the pump Inlet and the piping. It is recommended to use piping with bellows so that the vibration of the pump is not transmitted to the vacuum chamber.

3) Provide a vacuum valve, vacuum gauge and vent valve between the vacuum chamber and pump, as shown in Fig. 5.

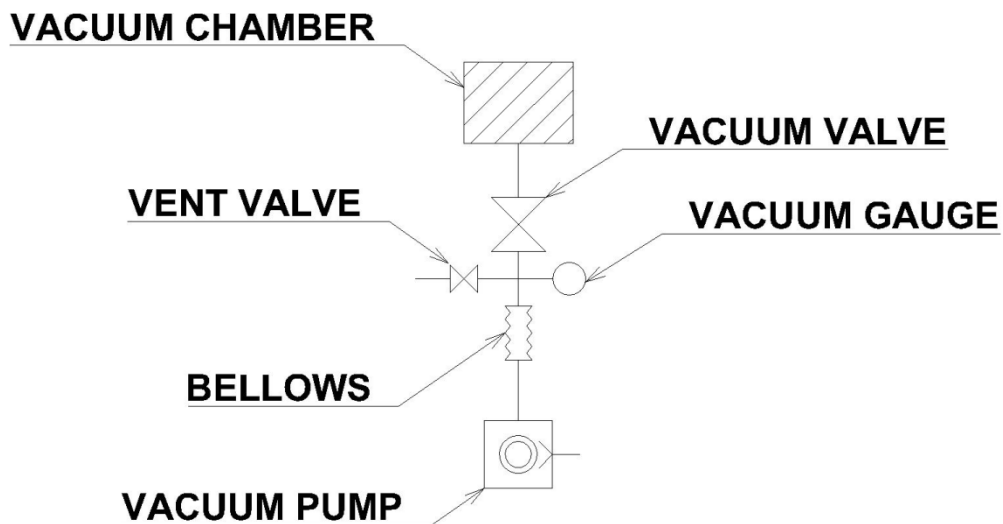

Fig. 5 Connection to vacuum chamber (example)



- 1) Should the Pump sucked the water or substance such as dust, powder and so on, it would impair the ultimate pressure and further cause a trouble.
- 2) You should put the Leak valve closer as possible to the Vacuum valve in order to prevent the oil from rising up to the Vacuum chamber when the Pump stopped. If you use it together with the mechanical booster pump, be sure to put the valve above the pump.
- 3) Metal mesh on the Suction inlet is put to keep foreign substances away from the Pump unit. Be sure not to take it off unless necessitated so to check it.

3.4 Exhaust Connection

Use the “G1” (JIS B0202-Parallel pipe threads-) for connection between the Outlet of the pump and the duct piping. It is recommended to provide an oil mist trap to reduce oil consumption and to trap oil mist.



WARNING

If the pipe connected to the Exhaust outlet had a small diameter or attached foreign substance inside, there is a risk that the pressure inside the Vacuum pump rises up to cause break or oil leak of the casing or Oil level gauge resulting in overload of the motor.



WARNING

1) Be sure to use products made of electricity-conducting material for the Duct piping. Should you used non electricity-conducting material, static electricity would be generated under passage of exhaust gas, generate the charged spark and cause a fire.

2) In the case of the process flowing combustible gas/susceptibility of substances to burn gas, you are requested to introduce the diluent gas. Flow the diluent gas from the intake side so that the gas concentration to be exhausted becomes lower than the explosion limit.

3.5 Electrical Connection

IMPORTANT



Conduct the electrical connection referring to the “Fig. 6 and Fig. 7”.

Use crimping terminals for the connection and tighten screws. Check also screws fixing the connector tighten.

Motor rotation direction is counterclockwise viewed from the motor side.

Be sure also to put a safety circuit such as Electromagnetic breaker for the electrical connection.



WARNING

Install and operate the product in compliance with the laws and regulations relating to the safety, e.g. Fire Defense Law, Electric wiring regulation and so on. In the country and region you use the product.



WARNING

Install an overload protector suitable for the capacity of the motor. If an overload protector is not installed, or if an overload protector that is unsuitable for the motor capacity is installed, the motor will be damaged leading to fire.

Table. 2 Electric capacity of the motor overload protector

AC200V～AC460V 3Phase

ポンプ型番 MODEL	モータ容量 kw	定格電流 RATED CURRENT A	配線用遮断機 Breaker A	サーマルリレー Thermal relay A	適合電線 power cords mm ²
VD151	0.55	2.90 (200V/50Hz)	15	2.90 (200V/50Hz)	2～3
		3.10 (220V/50Hz)		3.10 (220V/50Hz)	
		3.30 (230V/50Hz)		3.30 (230V/50Hz)	
		3.60 (240V/50Hz)		3.60 (240V/50Hz)	
		2.70 (200V/60Hz)		2.70 (200V/60Hz)	
		2.60 (220V/60Hz)		2.60 (220V/60Hz)	
		2.70 (230V/60Hz)		2.70 (230V/60Hz)	
		2.70 (240V/60Hz)		2.70 (240V/60Hz)	
		1.80 (380V/50Hz)		1.80 (380V/50Hz)	
		1.90 (400V/50Hz)		1.90 (400V/50Hz)	
		2.00 (415V/50Hz)		2.00 (415V/50Hz)	
		1.50 (380V/60Hz)		1.50 (380V/60Hz)	
		1.60 (400V/60Hz)		1.60 (400V/60Hz)	
		1.60 (440V/60Hz)		1.60 (440V/60Hz)	
1.70 (460V/60Hz)	1.70 (460V/60Hz)				
VD201	0.7	3.60 (200V/50Hz)	15	3.60 (200V/50Hz)	2～3
		3.80 (220V/50Hz)		3.80 (220V/50Hz)	
		4.00 (230V/50Hz)		4.00 (230V/50Hz)	
		4.20 (240V/50Hz)		4.20 (240V/50Hz)	
		3.20 (200V/60Hz)		3.20 (200V/60Hz)	
		3.20 (220V/60Hz)		3.20 (220V/60Hz)	
		3.20 (230V/60Hz)		3.20 (230V/60Hz)	
		3.30 (240V/60Hz)		3.30 (240V/60Hz)	
		2.20 (380V/50Hz)		2.20 (380V/50Hz)	
		2.20 (400V/50Hz)		2.20 (400V/50Hz)	
		2.40 (415V/50Hz)		2.40 (415V/50Hz)	
		1.80 (380V/60Hz)		1.80 (380V/60Hz)	
		1.90 (400V/60Hz)		1.90 (400V/60Hz)	
		2.00 (440V/60Hz)		2.00 (440V/60Hz)	
2.10 (460V/60Hz)	2.10 (460V/60Hz)				

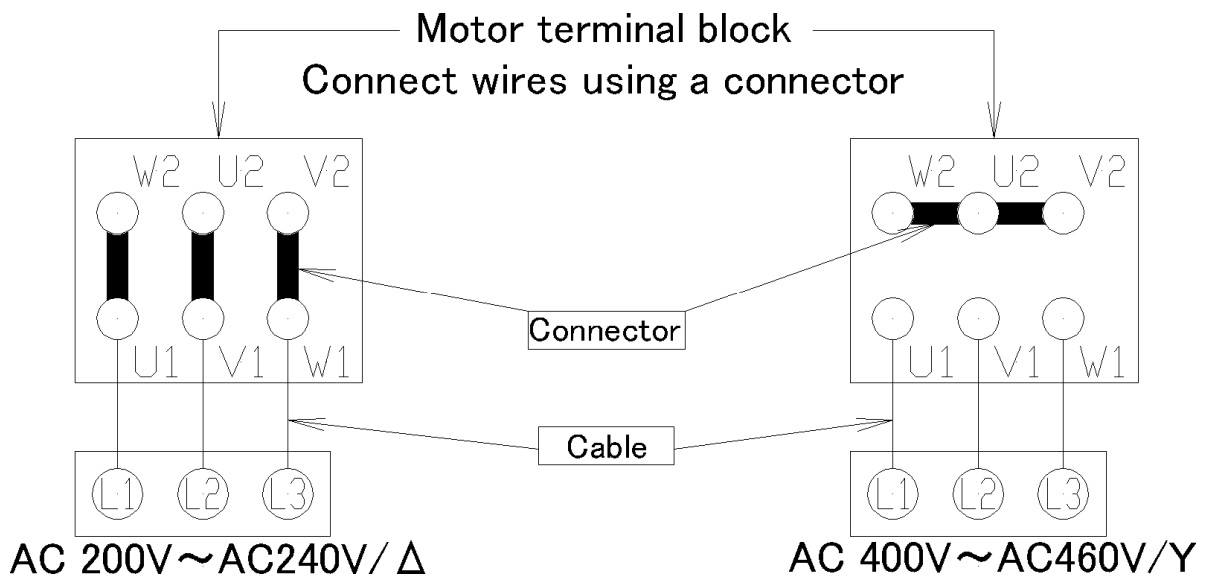

Fig. 6 Terminal box internal wiring diagram

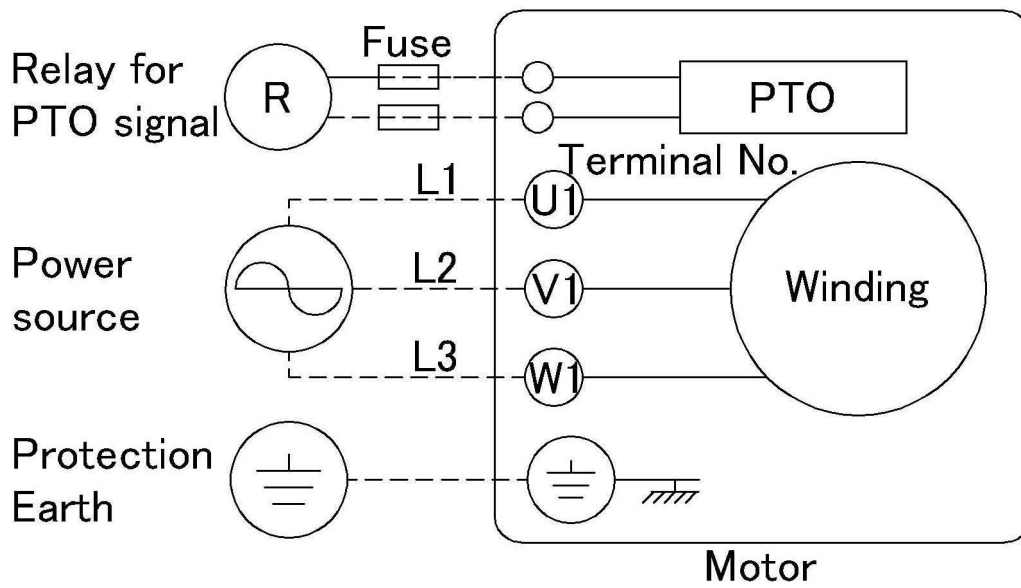

Fig. 7 Electrical wiring diagram



1) Turn OFF the Power Supply to do the electrical connection.

Never try to work on it on keeping the electricity turned ON.

2) Make sure to have the steady grounding. You have a risk of getting electrical shock when the machine caused a failure or electrical leakage.

The screw of the earth terminal at the motor side is provided with an “earth mark” in the terminal box.

Use power cords of the same diameter for the motor and earth.

3) Use the pump only at the rated voltage. Use at other than the rated voltage will interfere with correct operation of the overload protector, and result in the motor burning out, or fire.

4) The connector in the terminal box, with 380V–460V and 200V–240V power supply voltage, please change the wiring.



1) Be sure to put an overload protective device conforming to the motor capacity.

You have a risk that the Motor burns out or causes a fire if you have not put such an overload protective device or put a device not conforming to the motor capacity.

You are also recommended to put a dedicated ground-fault interrupter.

2) Do the correct wiring work conforming to the Electrical Installation Technical Standard and Internal line cord. Wrong wiring work might cause a fire.

3) The larger cable gland is for wires having a diameter of $\phi 8$ to $\phi 13$, and the smaller one is for wires having a diameter of $\phi 5$ to $\phi 8$. Use a cable gland that is suitable for the size of the power cord to be used. (Refer to fig.2 and fig. 3)

4) Never fail to close the Terminal box cover to operate the Pump.

This motor incorporates a temperature sensor (PTO: which opens at 150°C) and leader wires are arranged in the terminal box. Use these wires to take out the signal wire.

Connect the temperature sensor (PTO) as shown in Fig. 7. The specifications of the temperature sensor are shown in Table 3.

Table. 3 Specification of the temperature sensor (PTO)

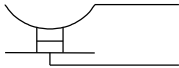
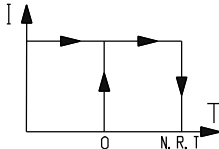
Type	Operating Principle	Operating Curve	Cut-off(A)
Normally closed thermostat PTO	Bimetallic strip, indirectly heated, with normally closed (N/C) contact 		2.5A at 250V with $\cos \phi 0.4$

N.R.T.: Nominal running temperature of the PTO



1) Be sure to use different power cords for the motor and for taking out a temperature sensor signal.

2) Apply a voltage of 250 V or less to the wire for taking out the temperature sensor signal. Connect a fast-acting fuse having a capacity of 250 V, 2.5 V between the relay circuit and temperature sensor.

4. Operation

4.1 Caution on Operation



WARNING

This pump is not pressure-proof.

Never run the Vacuum pump on blocking up the exhaust outlet, putting any device that hampers the gas passage or putting any oil mist trap not conforming to the ULVAC pump. There is a risk that the pressure inside the rises up as far as the Pump unit and/or Oil level gauge breaks or the Motor gets overloaded.

This product is not made as the withstand pressure structure. Ensured pressure value of the Pump shall be 0.03MPaG (0.3kg/cm²G) (Gauge pressure).

If any valve was put to a pipe after the Exhaust outlet, check and ensure that it is open.



CAUTION

1) The Pump oil might deteriorate in a shorter time depending on the use.

It is recommended to replace the first Pump oil within ten days after operation start and see how it got dirty to determine the oil replacement cycle.

2) If the Pump breathes in a lot of water or the like, you should replace the oil more frequently. If kept operation without getting rid of breathed water, it would deteriorate lubrication of the oil and further help corrosion of the Pump inside and result in causing a failure.

Do not store the product keeping sucked the water.

3) If the Pump breathed in chemical material such as acid, immediately replace the oil as it would cause the rust during the stop in one night to make the system e not applicable to operate.

We shall be not liable to the durability to chemical material.

4) You should also replace the oil if breathed in the solution to deteriorate lubrication of the oil as it would also cause biting inside. You shall have a risk if breathed in the solution in operation even you replaced the oil.

5) Caution shall be required for the operation under high pressure range.

The maintenance cycle becomes short by the pump becoming high temperature.



CAUTION

1) Continuous operation one hour or more under high pressure 1000Pa or more would increase the oil volume that are discharged as the oil mist and cause rapid parts wear or cause a trouble such as burning.

You are recommended to control the oil level on regularly supplying the pump oil. The maintenance cycle might become shorter.

2) Upon continuously operating with high inlet pressure, the oil temperature becomes very high temperature. As a result, the oil sharply deteriorates, and the attained pressure and the exhaust speed go bad, and it causes the failure such as high speed abrasion of the parts and burn-in. Frequently perform replacement of the pump oil.

4.2 Operation Start

Before starting the pump, check the following again.

- 1) Piping and wire connection are completed (Refer to the “3.3 Air Suction Piping”, “3.4 Exhaust Connection” and the “3.5 Electrical Connection”).
- 2) Checking the oil level (Refer to “3.2 Lubrication”) Ensure that the oil level is between the two level lines on the oil level gauge.
- 3) Checking the rotating direction (Refer to “3.5 Electrical Connection”) Close the vacuum valve on the Inlet side, open the vent valve, and run the pump for two to three seconds to check the rotating direction of the motor. If the motor is rotating in the correct direction (Counterclockwise as viewed from the motor side), pressure will lower. If it is reversed, interchange two of the three wires shown in Fig. 6 and fig.7.
- 4) After checking (1), (2) and (3) above, close the vent valve and run the pump. Here, ensure that the vacuum gauge between the vacuum valve and the pump indicates a pressure close to the ultimate pressure.

1) The Vacuum pump gets high temperature during operation.

VD151 : temperature increase under non-load operation : 25°C,

temperature increase under high-load operation : 45°C

VD201 : temperature increase under non-load operation : 20°C,

temperature increase under high-load operation : 78°C

Provide the appropriate protection in order to avoid the contact with the surface. Use the pump assembling inside the system.

Refrain from touching the Motor and Pump unit until the Pump cools down after having stopped operation.

2) Refrain from touching any part other than valve when operating the Gas ballast.

3 Ensure to close the Gas ballast to start the operation.

The oil might jet out during operation around high pressure range.

4) Oil mist would appear through the Exhaust side if operated around high pressure range.



Follow the process described below if the rotation at start was not smooth;



- 1) Check first the oil level and fill it appropriately.
- 2) The oil might enter inside the Pump cylinder if you left the Pump stopped longtime (three days or more) even you kept the atmospheric pressure inside the Pump when stopped it last time. The Overload protective device might work if you attempted to restart the Pump under such a condition.

This time, do the inching start of the Pump (repeat turning ON/OFF in a short time) several times.

4.3 Operation Stop

- 1) Close the vacuum valve on the Inlet side, open the vent valve to vent the pump, and shut down the pump.
- 2) After shutdown, open the vent valve to vent the pump to atmospheric pressure.



The Vacuum pump gets high temperature during operation.

VD151 : temperature increase under non-load operation : 25°C,

temperature increase under high-load operation : 45°C

VD201 : temperature increase under non-load operation : 20°C,

temperature increase under high-load operation : 78°C

Refrain from touching the Motor and Pump unit until the Pump cools down after having stopped operation.



- 1) **Ensure to close the Vacuum valve and open the Leak valve to stop the Pump. If failed in following this procedure, the Pump cylinder gets filled with the oil in several minutes, which might make difficult to restart operation or give damage to the Pump unit.**

Further the oil might accidentally flow back to the Vacuum tank.

- 2) **If failed in closing the Vacuum valve, the vacuum might leak from the Exhaust side through the Pump unit.**

4.4 Gas Ballast Function

This product is installed with the Gas ballast function as standard. It is applicable to breathe in the condensed gas such as the steam and solution vapor. Breathed condensed gas shall be liquefied through the Compress process of the Pump, mixed with the Pump oil and then cycled mixed together inside the Pump unit. This status brings you the same situation that you used the high steam pressure oil that raises the ultimate pressure. It also shortens the life cycle of the Shaft seal since the oil lubrication shall deteriorate.

If introduced the air or dry nitrogen through the Gas ballast valve just before the Pump compression process, the condensed gas is not liquefied but exhausted with the air through the Exhaust valve.

To use the Gas ballast, breathe in the air through the Gas ballast valve before sucking in the condensed gas and operate the Pump around twenty minutes; this is because the “Gas ballast effect” becomes larger as the Pump temperature is higher. Wait until the Pump temperature rises around 65° C to open the Vacuum valve (Fig. 5) So as to operate the Pump. The “Gas ballast effect” under low temperature shall be lower than the specified process performance.

Note further that keeping the Gas ballast valve open when not breathing in the condensed gas shall cause the Pump oil splashing and power loss and further rise the ultimate pressure. You have to note also that the condensed gas might remain in the Pump oil after you have exhausted a lot of condensed gas or exhausted the condensed gas (air or gas that contains less water or other steam that contaminates the oil) without opening the Gas ballast valve since the process capacity of the condensed gas by the Gas ballast valve is limited.

In such a case, close the Vacuum valve, breathe in the air through the Gas ballast valve and idle operate the Pump. Then the oil temperature shall rise up and be cleaned by means of the Gas ballast effect. Keep on idle operating the Pump without opening the Gas ballast valve as far as the specified ultimate pressure is attained. You need to replace the Pump oil if it was not cleaned after operated long time.



WARNING

- 1) **The Vacuum pump gets high temperature during operation. As the Gas ballast valve also gets high temperature, be sure to wear protective gear such as a pair of gloves.**
- 2) **Ensure to close the Gas ballast valve to start operating the Pump. The oil might jet out of the Gas ballast valve during the operation around high pressure range.**



CAUTION

If you kept opening the Gas ballast valve when not exhausting the condensed gas, it might cause the oil splash, power loss or ultimate pressure rise.
Keep the Gas ballast valve closed when not exhausting the condensed gas.

4.5 Vacuum Pump Oil For cold district

Starting the Pump operation might become difficult in winter season or in the cold district.

This is the overload phenomenon caused by increased viscosity of the pump oil. To make sure, you should confirm that the capacity of the motor overload protective device conforms to the motor rated value, the pump is not broken and the cable does not have abnormality. Then, warm up the Pump oil or replace the oil with the Vacuum pump oil ULVOIL R-4 having lower viscosity.

Recommended type of oil:

- 1) ULVOIL R-7 (standard oil)
- 2) ULVOIL R-4 (Cold area or winter time)

IMPORTANT

1) When temperature is low, and a pump does not run, warm up the pump oil or turn the pump on and off several times in short intervals.

2) When the pump stops after run for several seconds, you try to move it while putting slow leak in it, there is the thing that the pump can run consecutively (refer to fig.5).

As the pump warmed, you close the slow leak valve, and please return it to regular running.



WARNING

It is better to use the ULVOIL R-4 having less viscosity that enables you to start rotating the Pump around 4° C.

You should, however, replace it with the ULVOIL R-7 if the temperature gets 10° C or more. Be cautious as using the ULVOIL R-4 in warm season would cause such troubles as sealing error, oil leak or more serious trouble, due to its lower viscosity.

ULVOIL R-4 is unfitted for high load operation. When performing the high load operation, use ULVOIL R-7, and either warm the pump oil or perform the pump jog at several times, and the start up it.

4.6 Oil mist trap (Optional)

The oil mist trap can be mounted to trap the oil mist discharged from the pump.

The TMX-1 model is for the VD151/VD201. The trap with adapter can be set on the pump instead of the original exhaust pipe at the outlet.

- 1) At the outlet of the pump, remove the original exhaust pipe.
- 2) You assemble the adapter and TMX-1 to establish the pump.
- 3) Between the adapter and TMX-1, put the O-ring(G85).

Four small screws and washers fix adapter and TMX-1.

* When the adapter is attached to the TMX-1, please remove the baffle inside the trap.

- 4) Between the pump and adapter, put the O-ring(G30). Please set up the exhaust vent.

For more information, please see the instructions OIL MIST TRAPS.

IMPORTANT

Provide the time to return oil from TMX-1. When using VD151/VD201 at 10,000Pa or more,, arrange so that the oil returns from TMX-1 to the pump making the not exhausted time (5 minutes) once every 30 minutes. Upon continuing the continuous exhaust at high pressure, the oil blocks the filter, and the pressure on the exhaust side becomes high, and the oil blows out from the exhaust port, and also the pressure may go bad due to the oil shortage in the pump.

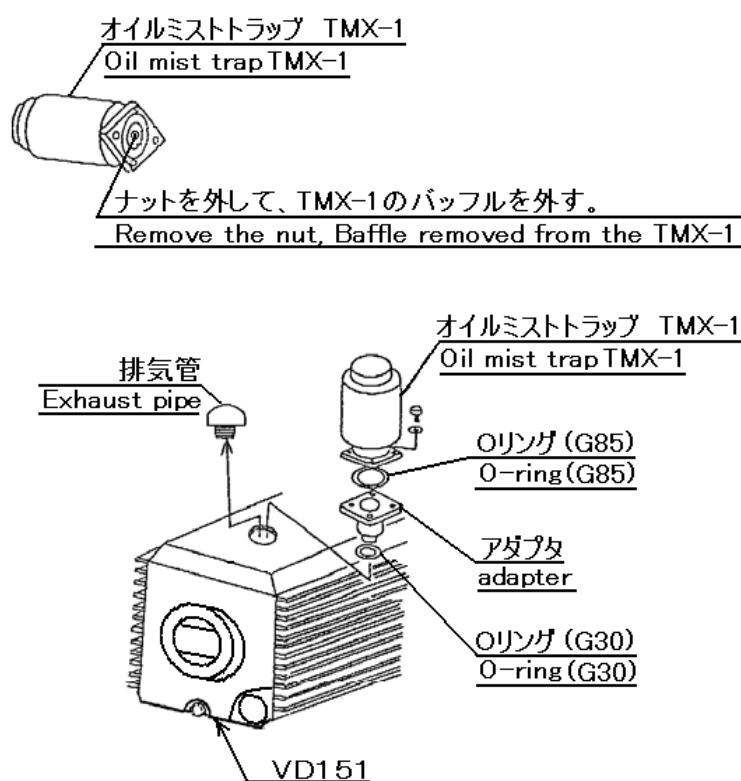

Fig. 8 To use Oil mist trap “Model TMX-1” for “VD151 or VD201”



WARNING

Limit value of the pressure inside the Pump is 0.03MPaG (0.3kg/cm²G) (Gauge pressure). If the pressure is raised, oil mist trap please exchange.

We recommend you to install a Pressure monitor.

To use the Oil mist trap, be cautious not to have clog of the filter in the trap. Too much clog would prevent the exhaust gas from passing through the filter, raise the pressure inside the Pump unit (include the oil mist trap) and might result in breaking it.

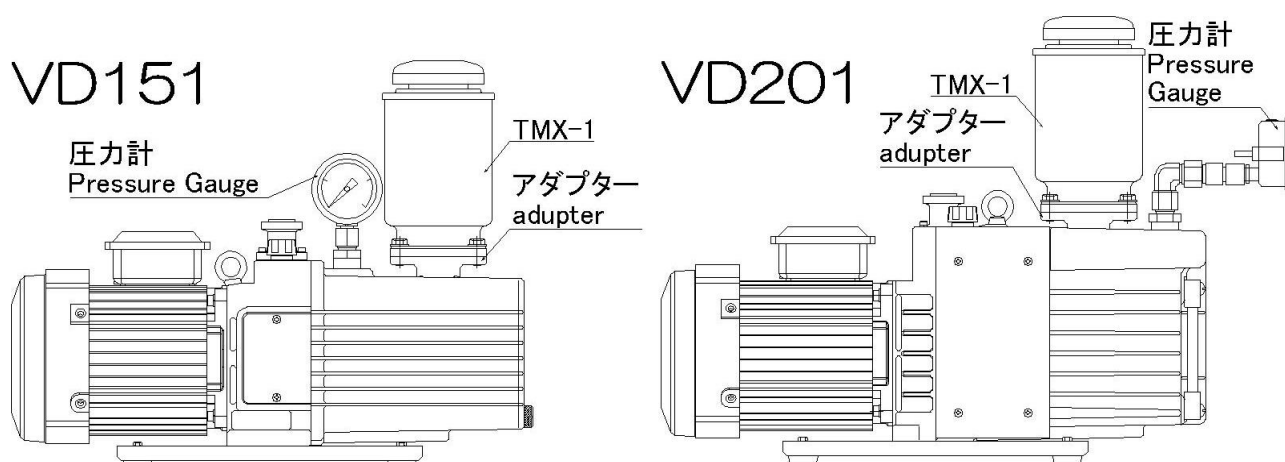

Fig. 9 When having mounted oil mist trap and adapter

5. Pump Performance

5.1 Ultimate Pressure

“Ultimate pressure” described in the catalogue and this document means “the limit value pressure obtained by the pump in a state not introducing any gas through the suction inlet (no load operation).” ULVAC measures the value by the Pirani gauge connected to the Pump suction inlet using the specified vacuum pump oil after having completely blocked out the Pump unit from the system.

Be cautious as the Pirani gauge as well as the thermocouple vacuum gauge would indicate a value 5 to 10 times much than the value that the McLeod gauge shall indicate. This is caused by the fact that the McLeod gauge shall get rid of the condensed gas constituent (mainly water) included in the measured gas.

Actual vacuum equipment on the site shall likely to raise the ultimate value higher than the catalogue value as the vacuum gauge was put far away from the Pump or maybe affected by the water drop, rust or other substances attached to the system inside wall or pipe, or water vapor and miscellaneous gas generated from attached substances. It is because the oil vapor pressure is raised up since the volatile gas melt in the Pump oil, foreign substance and gas sucked in the Pump from the vacuum chamber might contaminate the gauge head and/or decompose (deteriorate) the Pump oil constituent.

5.2 Exhaust Speed

Exhaust speed of the Oil rotary pump shall vary depending on the type and pressure of the sucked gas. It shall indicate the maximum exhaust speed in the high pressure range and lower speed little by little lower becomes the pressure.

Effective exhaust speed of this machine is the maximum value when it sucked in the dried air.

Fig. 10 show the relation of the suction pressure and exhaust speed.

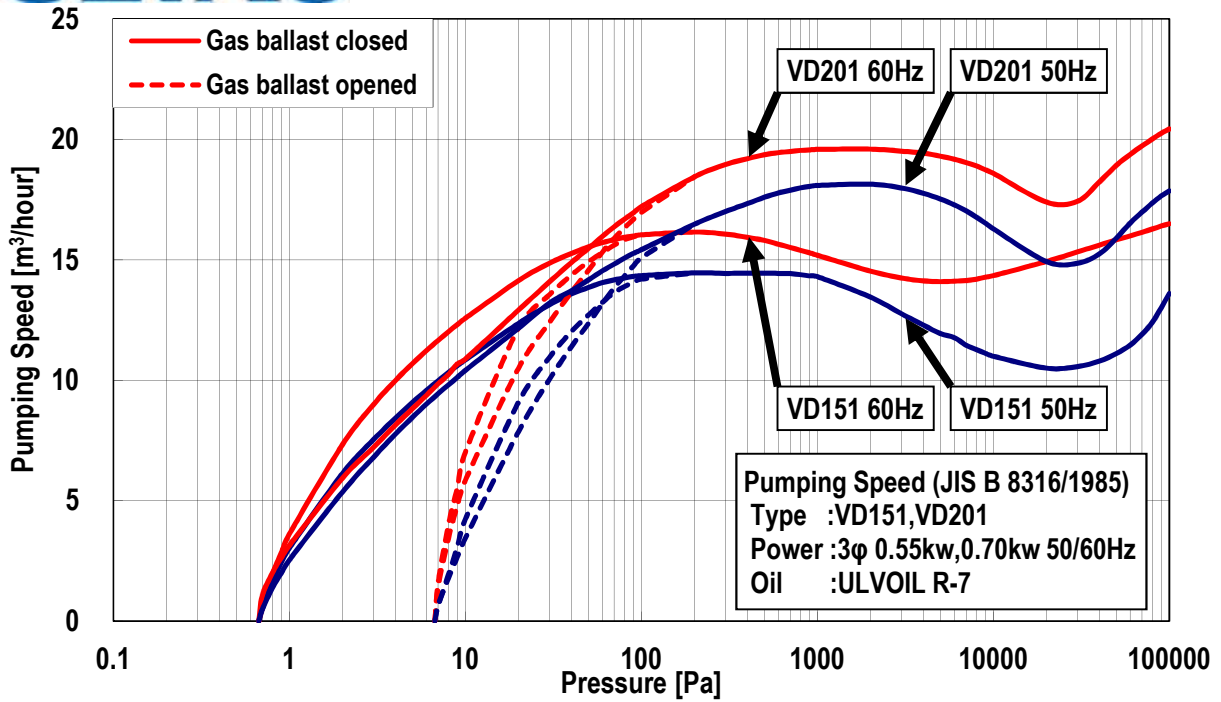

Fig. 10 Show the relationship between the suction pressure and pumping speed – MODEL VD151/VD201

5.3 Required Motive Energy

Motive energy to drive the Vacuum pump is a total value of the work of the mechanical element on the rotary friction (mechanical work) and the work of compressing the air (compression work) that becomes maximum when the suction pressure is between $3 \times 10^4 \sim 4 \times 10^4$ Pa.

If the pressure went down under 10Pa, the compression work becomes smaller, then most of the motive energy shall be spent on the mechanical work.

General use of the Pump shall indicate the largest load pressure range while the suction pressure was between $3 \times 10^4 \sim 4 \times 10^4$ Pa. Operation opening the Gas ballast valve would require larger motive energy at all the time as its compression work is large even the suction pressure was small. Further, when the temperature of the Pump site was low (in cold district or outdoor installation) starting the Pump would require larger motive energy since the Pump oil temperature was low and its viscosity is higher. However the motive energy value shall decrease and come stable as the oil viscosity comes lower while the Pump temperature shall rise as it goes through operation. “Motor” listed on the “Table 1 Performance specifications” are adopted taking into consideration of the above condition to drive the Pump.

6. Maintenance and Check

6.1 Maintenance

You should check following points at least once per three days while you continue operation.

Check the machine much more frequently during high overload operation (continuous operation 1kPa or more, repeated exhaust atmospheric pressure – vacuum).

- 1) Whether the Vacuum oil pump oil volume is between two level lines or not.
- 2) Whether the Vacuum pump oil is discolored or not.
- 3) Whether there is no foreign noise.
- 4) Whether there is anything strange in the Motor current value.
- 5) Whether there is no oil leak from the pump.

6.2 Regular Check

Although you have to consider checkpoints depending on the use of the Pump, you should check the following regularly; it is helpful to avoid trouble and extend the pump life cycle.



WARNING

- 1) Be sure to turn OFF the Power Supply to execute check and repair. You have a risk of getting electrical shock or injury by accidental sudden move.
- 2) Person other than Repair technician should not be in charge of dismantling, repairing or remodeling the product.
- 3) You have a risk of getting injured or electrical shock by a fire or erroneous move.
- 4) Do not touch the Motor, vacuum pump or piping during the pump operation and just after stopped it while the pump unit keeps high temperature. You have a risk of getting burned.
- 5) Should you found any malfunction or error, just turn OFF the Power Supply to prevent accident and ask the agency or closest Service Center for check and repair.

6.2.1 Pump Oil Level Check

The pump oil level should be between the two level lines (MAX and MIN) on the oil level gauge. (Refer to the " Fig. 3 Lubrication and oil level indication".)

6.2.2 Vacuum Pump Oil Check

The vacuum pump oil will be gradually deteriorated not only by contamination with sucked gas, but also by temperature rise during pump operation. Check the oil for contamination and viscosity and discoloring periodically.

If substances of low boiling point (water, organic solvent, etc.) are mixed with pump oil or sludge collects on the bottom of the pump case, the ultimate pressure cannot be recovered by one oil change, but the oil must be changed several times.

If the pump is operated using pump oil containing much moisture content, the ultimate pressure will rise, leading to poor functioning of the mechanical friction parts of the pump. In the worst case, the pump will seize up and cannot be rotated.

Table. 4 gives a guide for pump oil change frequency.

	<p>"VD201"</p> <p>The oil level gauge is for checking the pump oil level. Since the oil is not circulating between the pump case and the oil level gauge, contamination or discoloring of the oil may not be observed on the oil level gauge. Periodical ly drain approx. 50 ml of oil through the drain valve and check the oil for contamination and discoloring.</p>
---	--

Table. 4 Recommended replacement cycle of the vacuum pump oil

Purpose	Replacement timing
Vacuum system for study / laboratory, small vacuum system	Within 6 month ~ 1 year
Vacuum system for production, vacuum evaporation	Within 3 ~ 6 month
Vacuum valve exhaust system, large vacuum evaporation system	Within 3 month
Metallurgy vacuum system such as thermal treatment, melting and the like	Within 1 month
High vacuum dry, vacuum impregnation, vacuum formation and vacuum packing system	Within 1 month
Low vacuum dry, pug mill and food packing system	Within 1 week

1) The Pump oil might deteriorate in a shorter time depending on the use. It is recommended to replace the first Pump oil within ten days after operation start and see how it got dirty to determine the oil replacement cycle.

2) If the Pump breathes in a lot of water or the like, you should replace the oil more frequently. If kept operation without getting rid of breathed water, it would deteriorate lubrication of the oil and further help corrosion of the Pump inside and result in causing a failure. Do not store the product keeping sucked the water.

3) If the Pump breathed in chemical material such as acid, immediately replace the oil as it would cause the rust during the stop in one night to make the system not applicable to operate. We shall be not liable to the durability to chemical material.



4) You should also replace the oil if breathed in the solution to deteriorate lubrication of the oil as it would also cause biting inside. You shall have a risk if breathed in the solution in operation even you replaced the oil.

5) Caution shall be required for the operation under high pressure range. The maintenance cycle becomes short by the pump becoming high temperature.

1) Continuous operation one hour or more under high pressure 1000Pa or more would increase the oil volume that are discharged as the oil mist and cause rapid parts wear or cause a trouble such as burning.

You are recommended to control the oil level on regularly supplying the pump oil. The maintenance cycle might become shorter.

2) Upon continuously operating with high inlet pressure, the oil temperature becomes very high temperature. As a result, the oil sharply deteriorates, and the attained pressure and the exhaust speed go bad, and it causes the failure such as high speed abrasion of the parts and burn-in. Frequently perform replacement of the pump oil.

To change pump oil, proceed as follows.

- 1) Shut down the pump and open the drain port to drain the oil in the pump case.

Upon completion of draining the oil, close the drain port again and run the pump under no load for approx. 5 seconds to drain the oil from the cylinder.

- 2) Close the drain port and fill fresh oil through the oil filling port. (Refer to Fig. 4)

Pour oil until the oil level comes between the two level lines of the oil level gauge.

- 3) If the oil is severely contaminated, fill fresh oil and run the pump for several minutes under no load to clean the pump interior. Repeat this operation several times depending on the degree of oil contamination.

- 4) After changing the oil with fresh oil, run the pump to warm it up and then check the ultimate pressure.

- 5) If the specified ultimate pressure cannot be attained by oil change, sludge or other deposit may have collected on the bottom of the pump case. In that event, overhaul is required. Contact your local ULVAC organization or representative.



DANGER



If the Pump was used to exhaust the toxic gas, the Pump oil as well as the Pump unit shall become toxic. Pay a full attention.



CAUTION



- 1) Wear protective gear such as rubber gloves, protective goggles and the like.
- 2) Be sure to look through the "1. 2 Chemical Material Safety Data Sheet" before the lubrication.
- 3) Should the Vacuum pump oil touched to your hand or entered in your eye, immediately follow the emergency treatment described on the MSDS.



CAUTION

Ensure to use the vacuum pump oil designated by ULVAC. Operation using oil other than designated shall be out of our guarantee as it might impair the pump performance and shorten the life cycle.

6.2.3 Oil Leak Check

The Pump system needs repair if occurred any oil leak from the Shaft sealing or Pump unit. Type of the seals and O-rings are listed at the end of this document. Please contact the Service Center close to you for purchase and repair.

6.2.4 Checking The Gas Ballast Function

When used the Gas ballast function, the valve or in the introduction passage inside the Pump may be stuck in the dust. Replacement parts and repair support at the local service center. Please contact us.

6.2.5 Checking The Metal Mesh at The Suction Inlet

The Suction inlet might be clogged by the dust contained in the gas breathed in from the Vacuum chamber and thus the Pump performance might be impaired.

If there is the metal mesh is dirty, please wash that.

Further it is anticipated that any welding scale drops off in the pipe particularly at the beginning of the system start. Be fully cautious.

6.2.6 Checking The Noise and Abnormal Vibration

Checking around the pump

- 1) Check whether bolts and nuts and the like fixing the pump are loose or not.
- 2) Check whether pipes connected to the inlet/outlet are loose or not.
- 3) Check and ensure that there is no leakage from the piping and valves.

Checking the pump

Please refer to the “6.5 Trouble check list.”

Should the condition was not recovered after having checked points indicated there, please contact the closest Service center.

6.2.7 Checking The Coupling and Spider



The spider of the coupling that connects the pump body and the motor is made of rubber. Replace it if the spider is damaged. Please contact the closest Service center.

Replace it once a year by rule of thumb. If the pump is started and stopped several hundreds of times a day, however, shorten the replacement frequency.

- 1) Stop the pump and turn OFF the Power Supply. Disconnect the power cable of the motor.
- 2) To take out the spider, remove which fix the motor to the pump main unit, and remove the motor.
Then the coupling can be removed and the spider taken out.
- 3) After inspecting the spider, mount the spider to either of the two coupling, and adjust the position so that both claws of the couplings are engaged with each other as shown in Fig. 11.
- 4) Put the four bolts (M6x20) removed in the item (3) above.
(Recommended tightening torque: 10 N·m)
- 5) Execute the wiring.

Connect the concave section (female) of the pump unit with the convex section (male) of the motor, push the motor into the pump so that both connecting surfaces come completely into contact with each other, and fix the motor with bolts.

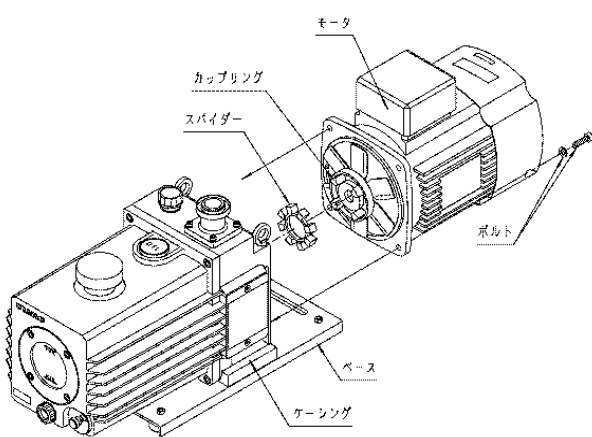
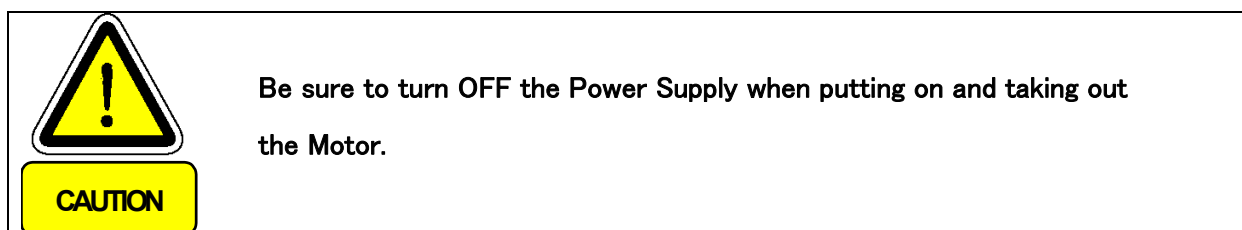

VD151

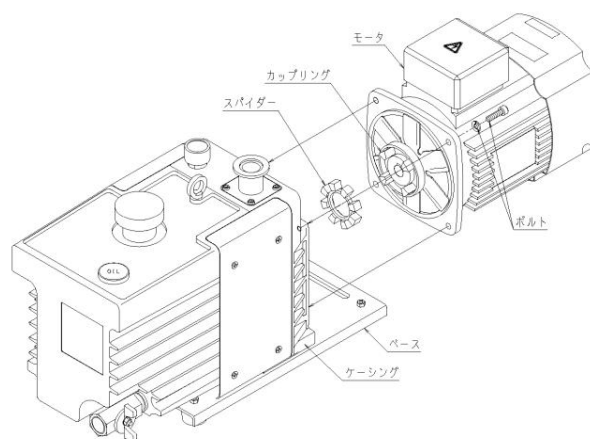

VD201

Fig. 11 Replacement of coupling spider

6.2.8 Checking The Oil Mist Trap

To use the Oil mist trap, be cautious not to have clog of the filter in the trap. Too much clog would prevent the exhaust gas from passing through the filter, raise the pressure inside the Pump unit and might result in breaking it.

Limit value of the pressure inside the Pump is 0.03MPaG (0.3kg/cm²G) (Gauge pressure). We recommend you to install a Pressure monitor. Refer to the Instruction Manual of the Oil mist trap as for the install position of the Pressure monitor.

Oil mist trap from the oily smoke out will continue, Oil mist trap please exchange.

6.2.9 Checking the drain valve

If you leave the drain valve semi-open for several months, it might get reshaped that you might not be able to shut the pump all the way. When storing the pump, please make sure the valve is completely shut. If you are using the plug instead of valve, the same situation will be applied.

6.3 Checkup after storage for a long period

Long term storage of the Vacuum pump without operation might possibly cause trouble in operation caused by rust

If you kept the Pump long time without operating it, ask a closest Service Center for the check.

6.4 Overhaul

If there found remarkable Pump contamination or performance deterioration due to the operation condition, you are recommended to conduct regular overhaul regardless of the check items described above.

Overhaul shall be required to keep the performance as well as the safety and further to continue the production on forecast.

Please contact the Service Center close to you listed at the end of the document as for the overhaul. Do not remember to fill and submit the Contamination certificate enclosed in the end of the document.



WARNING

We would be obliged to refrain from handling and/or executing maintenance of the product if the detail of used hazardous substance was not disclosed or the product has exhausted such substance that the detoxification process is hardly conducted.



CAUTION

You are requested to conduct the overhaul once a year.

If there found remarkable Pump contamination or performance deterioration due to the operation condition, you are recommended to conduct the overhaul earlier than one year period.

You shall be in need of replacing such parts as listed on the “9. Main spare parts” at minimum.

6.5 Trouble check list

Table. 5 Trouble check list

Trouble	Causes	Processing method	Reference
The Pump does not run.	1) Motor connection is wrong.	1) Check the connection.	3.5
	2) Safety circuit such as the Electromagnetic breaker is not correctly set.	2) Make the Safety circuit conform to the Motor specification.	0.6 3.5
	3) Oil viscosity got higher.	3) Replace the oil.	3.2 6.2.2
	4) Foreign substance entered in the Pump caused burning the Rotor or the like.	4) Conduct the overhaul (replacement of the Cylinder, Rotor, Cover and so on.)	6.4
	5) Reactive agent accumulated inside the Pump while the Pump was stopped after having exhausted the reactive gas.	5) Conduct the overhaul (cleaning inside the Pump, removal of reactive agent and so on.)	6.4
	6)The pump is not connected to the power supply.	6)Connect the pump to the power supply.	3.5
	7)The power switch is not turned on.	7)Turn on the power switch.	3.5
	8)Problem with power supply voltage	8)Set the power supply voltage to within $\pm 10\%$ of the rated voltage.	3.5
	9)The overload protector has actuated.	9)Press the reset button.	3.5

Trouble	Causes	Processing method	Reference
The Pump does not run.	10)The motor malfunctions.	10)Replace the motor.	3.5
	11)Moisture or solvents were sucked in, forming rust inside the pump.	11)Overhaul (replace the cylinder and rotor).	6.4
	12)Water absorption expands the vanes.	12)Overhaul (replace the vanes)	6.4
	13)Components inside the pump have burnt out.	13)Overhaul (replace the damaged components).	6.4
	14)Temperature is low	14) a) turn the pump on and off several times in short intervals. b) warm up the pump oil c) move a pump while putting slow leakin a pump d) Replace the oil. ULVOIL R-4	4.2 4.3 4.5 6.2.2
15)At the pump stop, Not to vent the pump to atmospheric pressure.	15)turn the pump on and off several times in short intervals.	4.2 4.3 4.5	

Trouble	Causes	Processing method	Reference
Abnormal noise sounds.	1) Motor rotation direction is reverse.	1) Do the connection again to correct the rotation direction.	3.5
	2) Cooling fan is touching.	2) Check the Cooling fan mount and clear the error.	6.2.7
	3) Rattling sounds on starting or stopping the machine.	3) There is no particular problem as it's a phenomenon caused by vanes that temporarily make irregular motions.	
	4) The oil is not circulating. a) Oil pit of the Cover or the like is clogged. b) Oil distributor valve has a trouble.	4) Overhaul. a) Clean the oil pit. b) Check and repair the Oil distributor valve.	6.4
	5) Vanes are not moving.	5) Overhaul. Wash out substances stuck to the vane.	6.4
	6) Panel screw is loose.	6) Tighten the screw.	6.2.6
	7) Oil is not filled.Oil is under the lowerlimit of the Oil levelgauge.	7) Overhaul (Replacement of the Cylinder, Rotor and Cover)	3.2 6.2.2
	8)Foreign matter has entered the pump.	8)Disassemble and clean the pump to eliminate foreign matter.	6.4
	9)Components inside the pump have burnt out.	9) Overhaul (replace the damaged components).	6.4

Trouble	Causes	Processing method	Reference
Pressure does not come down.	1) Pump exhaust capacity is smaller compared to the Vacuum chamber capacity.	1) Select another Pump type.	5.1
	2) Pressure measurement method is wrong.	2) Measure correctly the pressure.	
	3) Vacuum gauge is not appropriate.	3) Use the Vacuum gauge that matches the measurement pressure range and correctly calibrated one to measure the pressure.	
	4) Pipe connected to the Suction inlet is thin or connection distance is long.	4) Connect a pipe wider than inlet diameter and shorten the connection distance between the Vacuum chamber.	3.3
	5) Metal mesh at the Suction inlet is clogged.	5) Remove the pipe above the inlet and wash the mesh.	6.2.5
	6) Oil is not supplied to the specified volume.	6) Supply the oil to the specified volume.	3.2 6.2.2
	7) The oil is deteriorated.	7) Replace the oil.	3.2 6.2.2
	8) There is a leak in the pipe connecting with the Pump.	8) Use a Leak detector or the like to find out the leak position and stop it.	3.3
	9) Not using the ULVAC genuine oil.	9) Conduct the overhaul of the Pump and replace the oil with the ULVAC oil.	3.2 6.2.2 6.4
	10) The oil is not circulating. a) Oil pit of the Cover or the like is clogged. b) Oil distributor valve has a trouble.	10) Overhaul. a) Clean the oil pit. b) Check and repair the Oil distributor valve.	6.4
	11) Water entered inside the pump.	11) Replace the oil.	3.2 6.2.2

Trouble	Causes	Processing method	Reference
Pump surface temperature is abnormally high. (50°C or more higher than the room temperature)	1) Keeping continuous operation under high suction pressure.	1) Pump surface temperature would rise up around 100°C on continuous operation under high suction pressure. No problem.	3.2
	2) The oil is not supplied by the specified volume. (Less oil volume would lower the cooling effect of the Pump.)	2) Control the oil level. Supply the oil by the specified volume.	
	3) Suction gas is hot.	3) Install a cooling device such as the Gas cooler on the suction side.	
	4) The oil is not circulating. a) Oil pit of the Cover or the like is clogged. b) Oil disturb	4) Overhaul a) Clean the oil pit. b) Check and repair the Oil distributor valve.	6.4
	5) The pump perimeter is hermetically being sealed.	5) Make the ventilation available.	0.5.3
	6) A high temperature	6) Please use it in environment with the air conditioning	
Lot of oil mist blowing out of the Exhaust outlet.	1) Pump is filled over the specified volume.	1) Drain the oil until it gets the specified volume.	3.2 6.2.2
	2) Keeping continuous operation under high suction pressure	2) Put the Oil mist trap on the Exhaust side.	4.6
	3) Oil mist trap is clogged.	3) Replace the Oil mist trap.	4.6 6.2.8

Trouble	Causes	Processing method	Reference
Oil leak outside the Pump	1) Deterioration of the O-ring and/or Oil seal of the Case and Cover. 2) Oil inlet is loose.	1) Check the O-ring and Oil seal. Replace them if necessary. 2) Tighten again the Oil inlet.	6.2.3 6.4
Abnormal Motor current value	1) Foreign substance entered inside the Pump impaired the Motor rotation. 2) Abnormal sliding of the Rotor and/or vane. 3) Keeping continuous operation under high suction pressure.	1) Overhaul, removal of foreign substance inside the Pump. 2) Overhaul, check and repair inside. 3) Adjust the pressure.	6.4 6.4

7. Disposal

Make sure to keep in compliance with the laws and regulations established by the local governments to dispose the Vacuum pump. You should ask the dedicated disposal agency for the disposal particularly if the Pump has exhausted any toxic gas.

Note that you are requested to bear the cost and charges relating to the disposal.



WARNING

- 1) You should ask a special disposal agency for the disposal particularly if the Pump has exhausted any toxic gas hazardous to the human body. The Pump oil as well as the Pump unit gets hazardous.
- 2) Even if you do not have harmful gas emissions, is at the disposal of oil, Material Safety Data Sheet is provided, "DISPOSAL CONSIDERATIONS" read, please discard the oil.

8. Product Warranty

This product was shipped after rigid company inspection. However, in case any failure occurs under ULVAC's responsibility, such as defect in manufacturing and damage during transportation, Buyer shall inform ULVAC, Inc. or the local ULVAC representatives. ULVAC will repair or exchange it at free of charge.

8.1 Warrantable Items

- 1) Oil Rotary Vacuum Pump VD151
- 2) Oil Rotary Vacuum Pump VD201

8.2 Duration of guarantee

- 1) Domestic business in Japan: one year after shipping date from ULVAC.
- 2) Direct export transaction: one year after date of B/L

8.3 Warrantee scope

- 1) Domestic business in Japan:

Product, which has damage, caused by a failure on delivery. Products not satisfying meet the standard specifications although the product is used under the service conditions described in this document such as temperature range and power etc.

- 2) Direct export transaction:

Product, which has damage, caused by a failure on delivery. The warrantee scope shall confirm to INCOTERMS2010. Products not satisfying the standard specifications although the product is used under the service conditions described in this document such as temperature range and power etc.

8.4 Response procedure

- 1) Domestic business in Japan:

ULVAC send a replacement or Buyer return the defective items to ULVAC, Inc. or to the local ULVAC representatives for repair. If field service is required, Buyer shall ask ULVAC, Inc. or the local ULVAC representatives.

- 2) Direct export transaction:

ULVAC send a replacement or Buyer return the defective items to ULVAC, Inc. or to the local ULVAC representatives for repair. Return charge shall be paid by Buyer.

8.5 Disclaimer

- 1) Failure occurred after expiration of warranty period
- 2) Failure caused by force majeure, such as fire, storm and flood damage, earthquake, lightning strike, war etc.
- 3) Failure occurred due to carelessness handling or faulty usage.
- 4) Products remodeled, disassembled or repaired without ULVAC's acceptance
- 5) Failure occurred under abnormal environment, such as intense electromagnetic field, radiation, high-temperature, high-humidity, flammable gases, corrosive gases, dust etc.
- 6) Failure occurred by noise.
- 7) Product deficiency or secondary damnification occurred to Buyer, from law suit to ULVAC by third party for patent infringement.
- 8) The reason of the failure deemed below the specified usage condition by ULVAC technical staff.
- 9) Consumable parts

8.6 Others

- 1) In case, special agreement or memorandum for specifications is made individually.
- 2) Buyer shall inform ULVAC when this product is exported out of Japan. In the meantime, Buyer shall take necessary procedures according to Foreign Exchange and Foreign Trade Law.
- 3) As for the question and consultation, Buyer shall check the model and serial number and ask the local representative or ULVAC, Inc.
<http://www.ulvac.co.jp/eng/support/index.html>
- 4) The contents of this document is subject to change without notice in future.

9. Main Displacement Parts

Table. 6 Main displacement parts list (VD151)

Location	NO.	Product name	Standard size	Material	Q' ty
Coupling	1	Spider	Mark II for M63	NBR	1
Oil seal housing	2	Oil seal	HTC17-40-9	NBR	1
	3	O-ring	S-45	NBR	1
Casing	4	O-ring	S-30	NBR	1
	5	O-ring	JASO1016	NBR	1
	6	O-ring	P-12	NBR	1
	7	O-ring	P-35	NBR	1
	8	O-ring	V-175	NBR	1
Inlet pipe	9	O-ring	N-28	NBR	1
1st intermediate cover	10	Oil seal	SC17-30-7	NBR	1
	11	O-ring	S-5	NBR	1
	12	O-ring	S-30	NBR	1
	13	O-ring	S-70	NBR	1
	14	O-ring	G-55	NBR	1
1st Rotor	15	Vane spring	$\phi 2.6 \times 31$	SUS	5
1st Cylinder	16	O-ring	S-5	NBR	1
	17	O-ring	S-16	NBR	1
	18	O-ring	S-70	NBR	2
	19	Outlet valve	$\phi 13 \times \phi 9.5 \times 9$	FPM	3
	20	Outlet valve spring	$\phi 10 \times 20$	SUS	3
2nd intermediate cover	21	Oil seal	SC17-30-7	NBR	1
	22	O-ring	S-5	NBR	1
	23	O-ring	S-16	NBR	1
	24	O-ring	S-70	NBR	1
2nd Rotor	25	Vane spring	$\phi 2.6 \times 31$	SUS	2
1st Cylinder	26	O-ring	S-70	NBR	2
	27	Outlet valve	$\phi 13 \times \phi 9.5 \times 9$	FPM	1
	28	Outlet valve spring	$\phi 10 \times 20$	SUS	1
Side cover	29	Oil seal	SC15-30-7	NBR	1
	30	O-ring	S-12	NBR	1
	31	Check valve	$\phi 4 \times \phi 8 \times 5$	FPM	2
	32	Check valve spring	$\phi 5 \times 9$	SUS	2
Front cover	33	Level gauge gasket	$\phi 60 \times \phi 70 \times t1$	FKM70	1
	34	O-ring	JAS03056	NBR	1
	35	O-ring	P-12.5	NBR	1
	36	O-ring	S-20	NBR	1

Note 1: Screws are all metric screws conforming to the ISO standard.

Note 2:No.1: Techno-Tsukihoshi co.

No.2,No.10,No.21,No.29 : NOK CORPORATION

Table. 7 Main displacement parts list (VD201)

Location	NO.	Product name	Standard size	Material	Q'ty
Coupling	1	Spider	Mark II for M63	NBR	1
Oil seal housing	2	Oil seal	HTC17-40-9	NBR	1
	3	O-ring	S-45	NBR	1
Casing	4	O-ring	P-12	NBR	1
	5	O-ring	P-35	NBR	1
	6	O-ring	S-5	NBR	1
	7	O-ring	S-24	NBR	1
	8	O-ring	ISO C1950G	NBR	1
Inlet pipe	9	O-ring	N-28	NBR	1
1st intermediate cover	10	Oil seal	SC-17-30-7	NBR	1
	11	O-ring	S-5	NBR	1
	12	O-ring	S-24	NBR	1
	13	O-ring	S-85	NBR	1
	14	O-ring	G-55	NBR	1
1st Rotor	15	Vane spring	$\phi 2.6 \times 31$	SWP-A	5
1st Cylinder	16	O-ring	S-5	NBR	1
	17	O-ring	S-16	NBR	1
	18	O-ring	S-85	NBR	1
	19	Outlet valve	$\phi 13 \times \phi 9.5 \times 9$	FPM	3
	20	1st Outlet valve spring	$\phi 10 \times 20$	SUS	3
2nd intermediate cover	21	Oil seal	SC-17-30-7	NBR	1
	22	O-ring	S-5	NBR	1
	23	O-ring	S-16	NBR	1
	24	O-ring	S-85	NBR	1
2nd Rotor	25	Vane spring	$\phi 2.6 \times 31$	SWP-A	2
2nd Cylinder	26	Oil seal	SC-15-30-7	NBR	1
	27	O-ring	S-12	NBR	1
	28	Check valve	$\phi 4 \times \phi 8 \times 5$	FPM	2
	29	Check valve spring	$\phi 6 \times 10$	SUS	2
	30	Outlet valve	$\phi 13 \times \phi 9.5 \times 9$	FPM	1
	31	2nd Outlet valve spring	$\phi 10.2 \times 24.5$	SUS	1
Front cover	32	Oil level gauge Assy	KP-2320-01-024	FEP	1

Note 1: Screws are all metric screws conforming to the ISO standard.

Note 2:No.1: Techno-Tsukihoshi co.

No.2,No.10,No.21,No.26 : NOK CORPORATION

Declaration of Conformity

We

Company: ULVAC, Inc.

Address: 2500 Hagazono, Chigasaki, Kanagawa, (ZIP Code: 253-8543) Japan

declare under our sole responsibility that the products:

Product Name: Oil Sealed Rotary Vacuum Pump

Model No.: VD151, VD201

to which this declaration relates is in conformity with the following standards or other normative documents

EN 60034-1:1998+A1:1998+A2:1999+A11:2002(IEC34)	Rotating electrical machines
EN 1012-2:1996+A1	Compressors and vacuum pumps Safety requirements Part 2: Vacuum pump

following the provisions of

93/68/EEC
2006/42/EC

Low Voltage Directive
Machinery Directive

Subject products are manufactured and tested according to appropriate quality control procedures.

Date: 2010/06/10 2010/06/10

Signature: Kiyokazu Yanagisawa

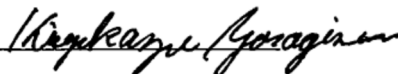



This mark is applied to the electronic information product sold in the People's Republic of China. The figure at the center of the mark is the validity date of environmental protection. This product does not influence the environment, the human body and the property during the period reckoning the manufacturing date as long as the caution for safe use regarding the products are observed.
 *The environmental protection validity date is not the product warranty period.

Table. Making format for names and contents of hazardous substances or elements

Name of parts	Hazardous substances or elements					
	Pb	Hg	Cd	Cr ⁶⁺	PBB	PBDE
Body	○	○	○	○	○	○

○: indicating that content of the hazardous substance or element in all homogeneous materials of the part does not exceed the requirements for concentration limits specified by SJ/T11363-2006.
 ×: indicating that content of the hazardous substance or element in, at least one kind of, homogeneous materials of the part exceeds the requirements for concentration limits specified by SJ/T11363-2006. Producer may further explain the technical excuse to the items marked with “X” perspecific conditions here.